

Cardioid Polar Pattern

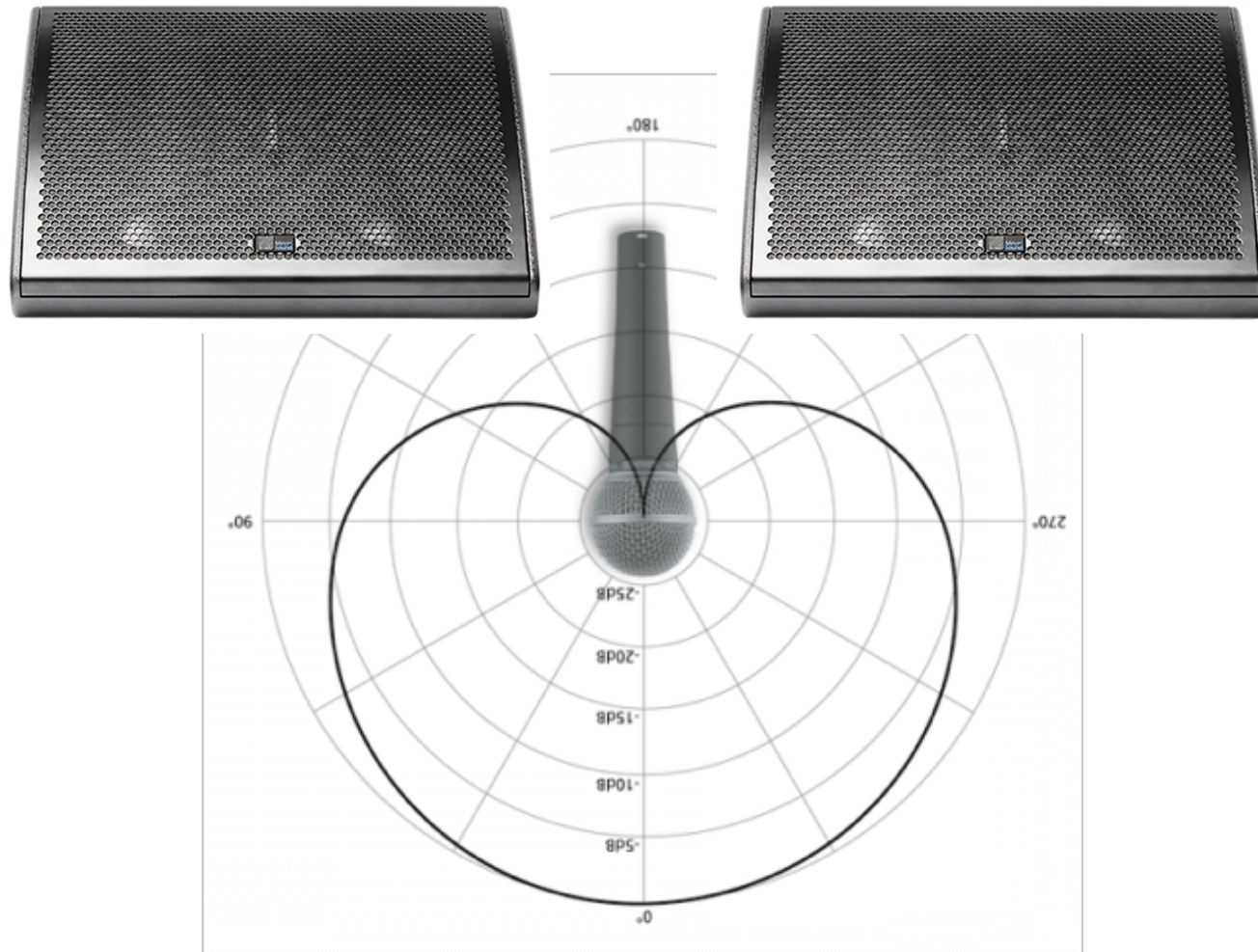

Correct Position for Monitors when using a Cardioid Microphone

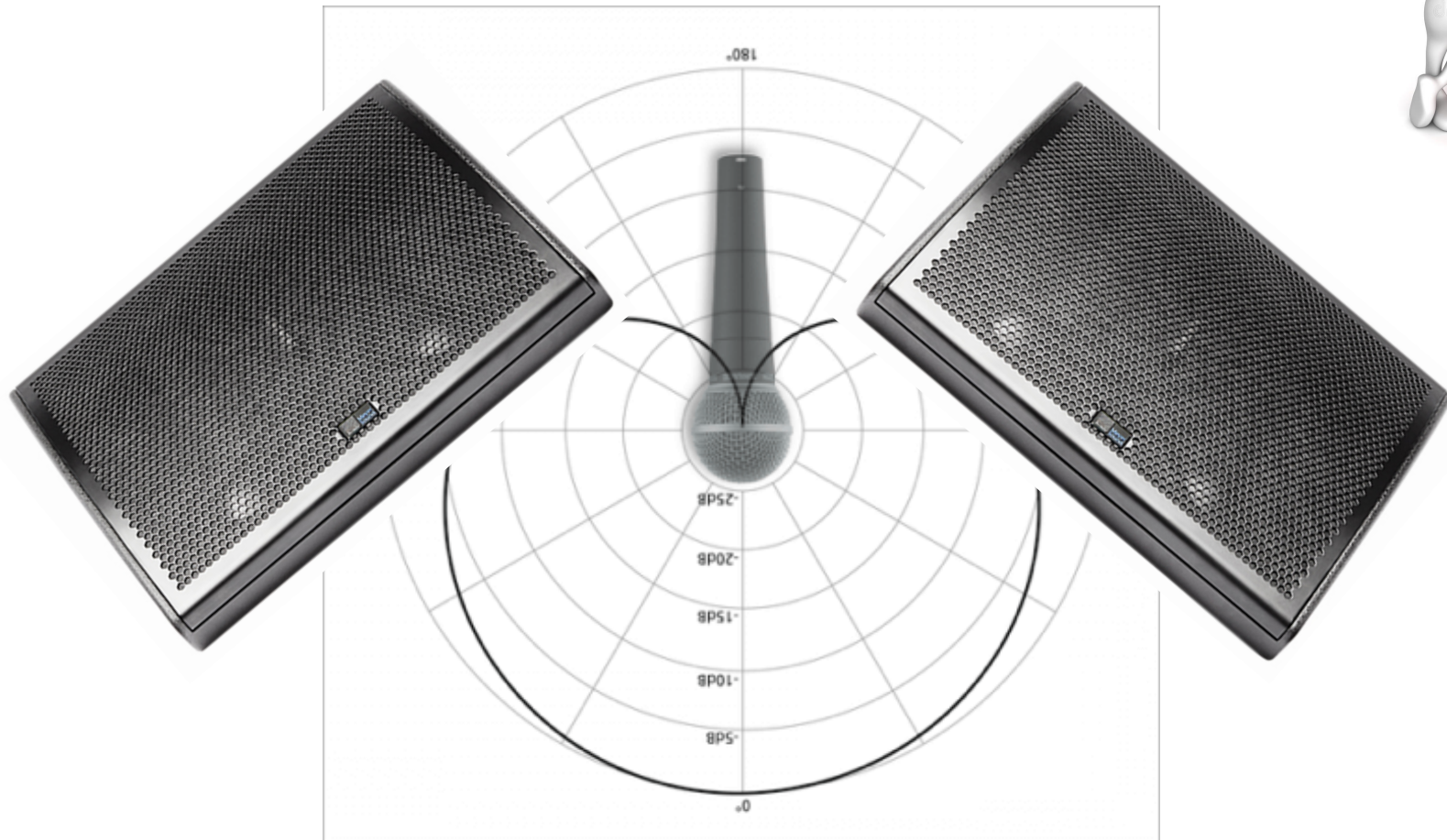

Incorrect Position for Monitors when using a Cardioid Microphone

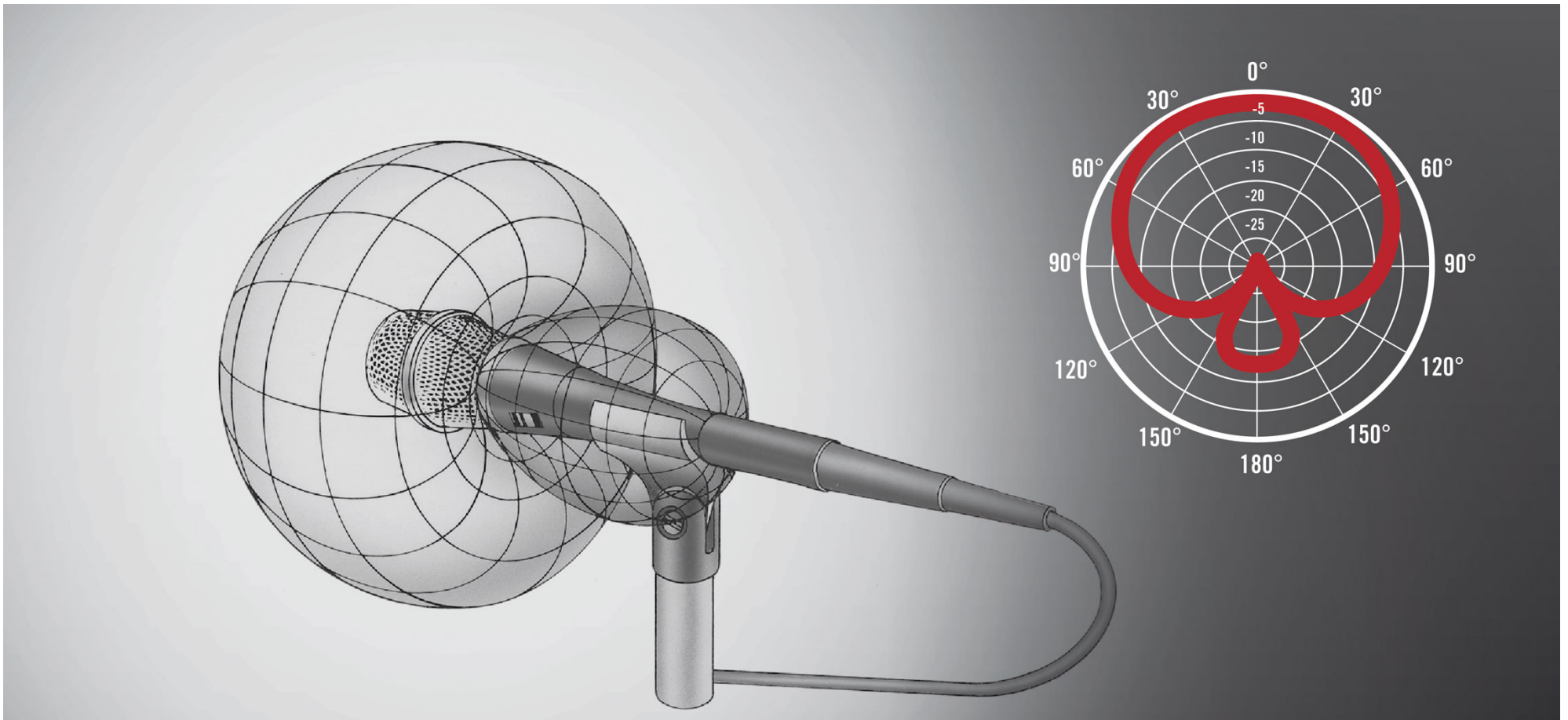

Super-Cardioid Polar Pattern

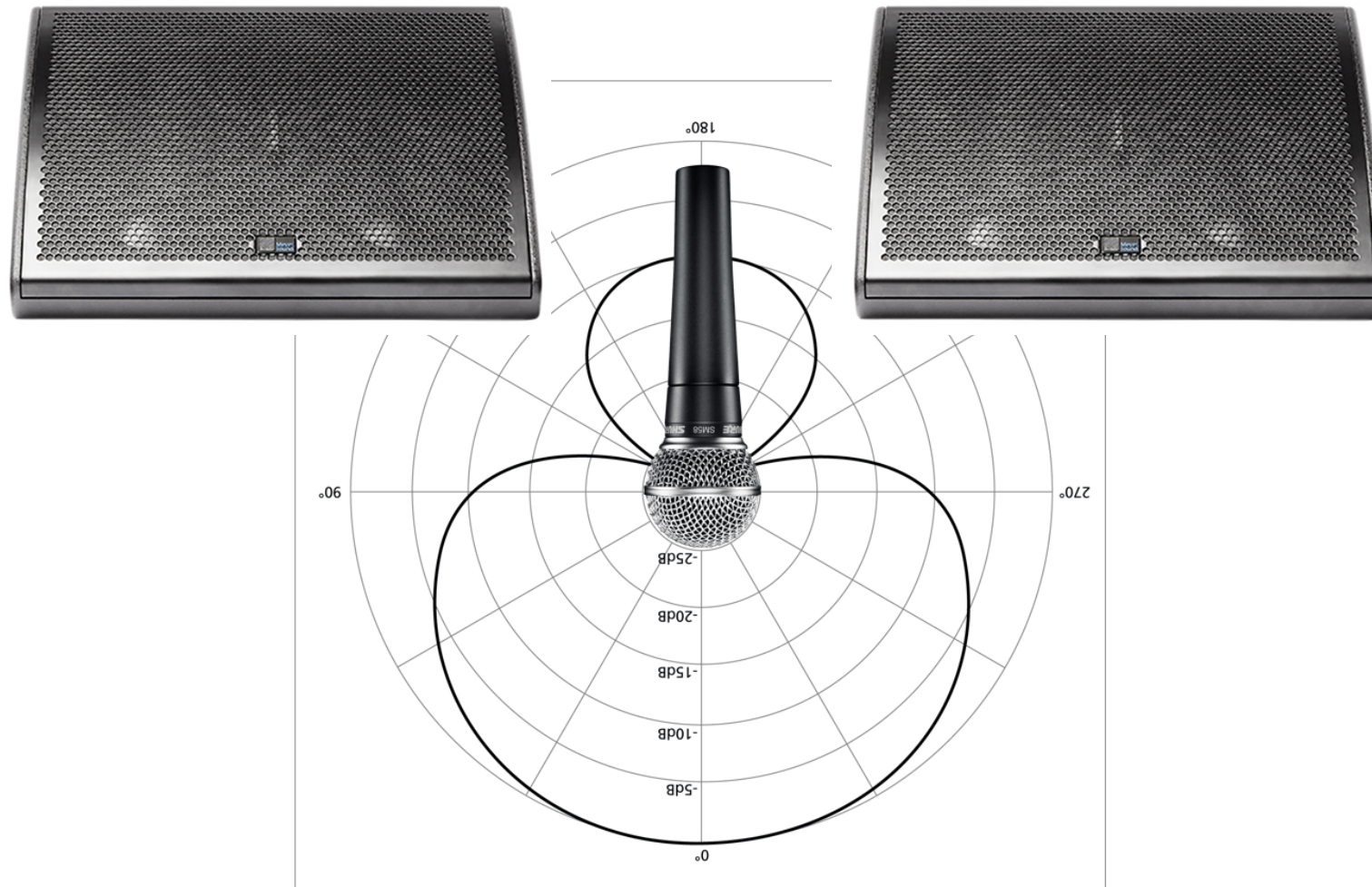

Not Ideal Position for Monitors when using Super- Cardioid Polar Pattern
(bigger spacing needed between the monitors - not effective for listening)

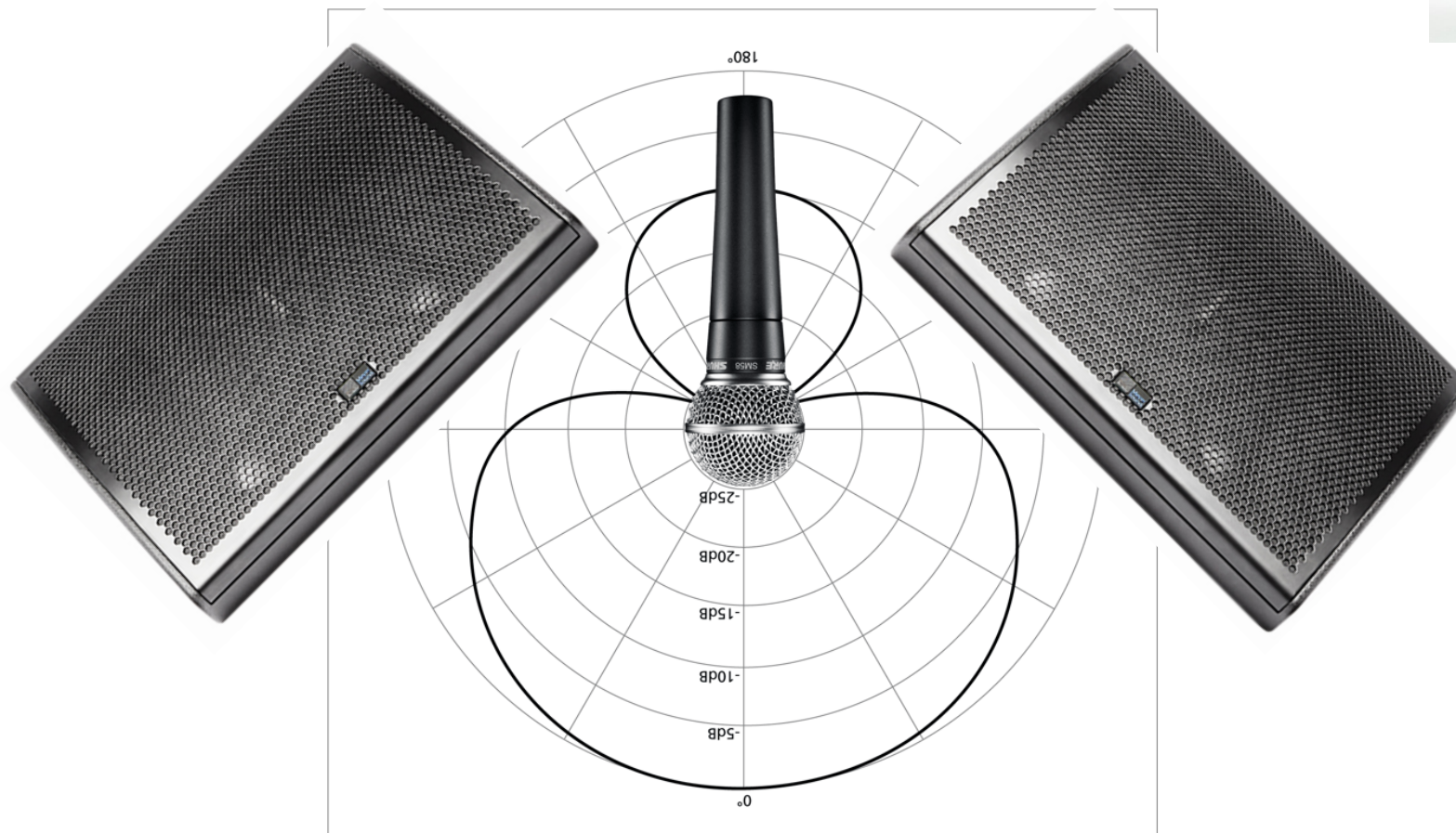

Correct Position for Monitors when using a Cardioid Microphone

Polar Patterns

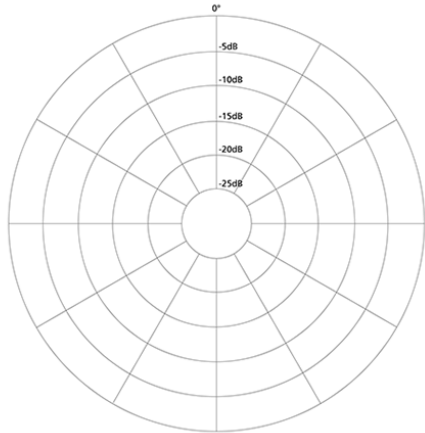

Empty

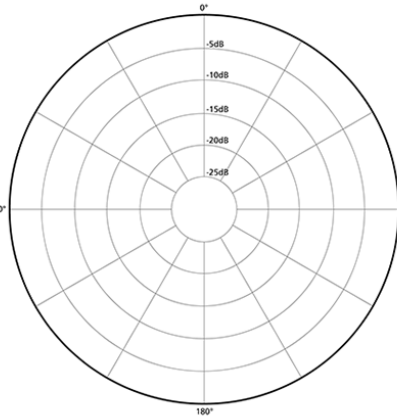

Omnidirectional

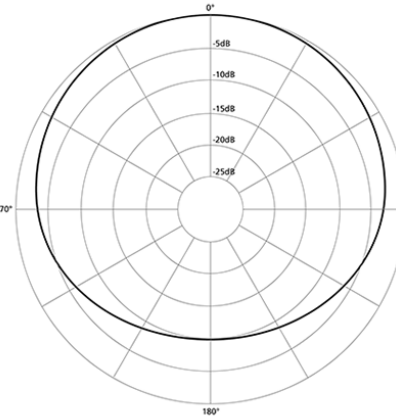

Subcardioid

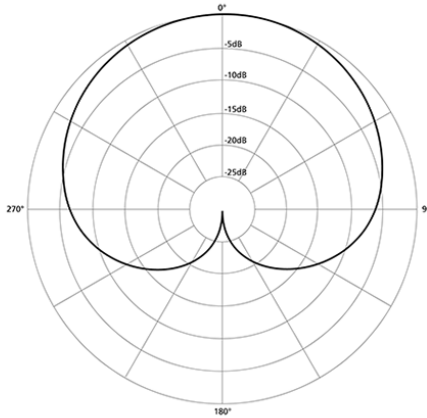

Cardioid

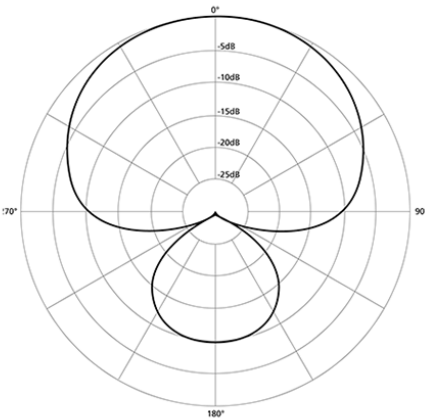

Supercardioid

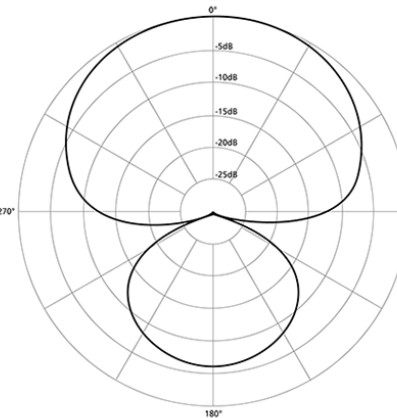

Hypercardioid

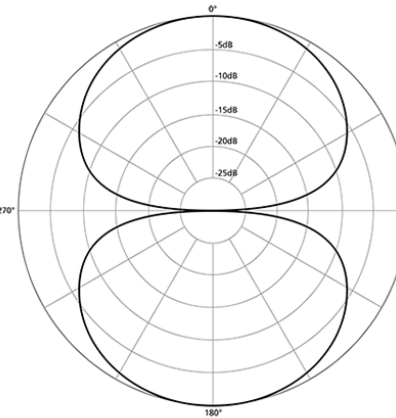
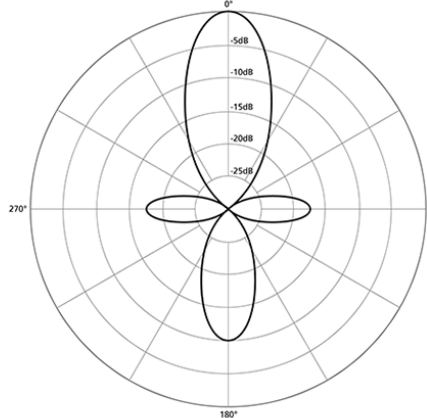

Figure 8



Shotgun