

# Sound Transducer | Loudspeaker

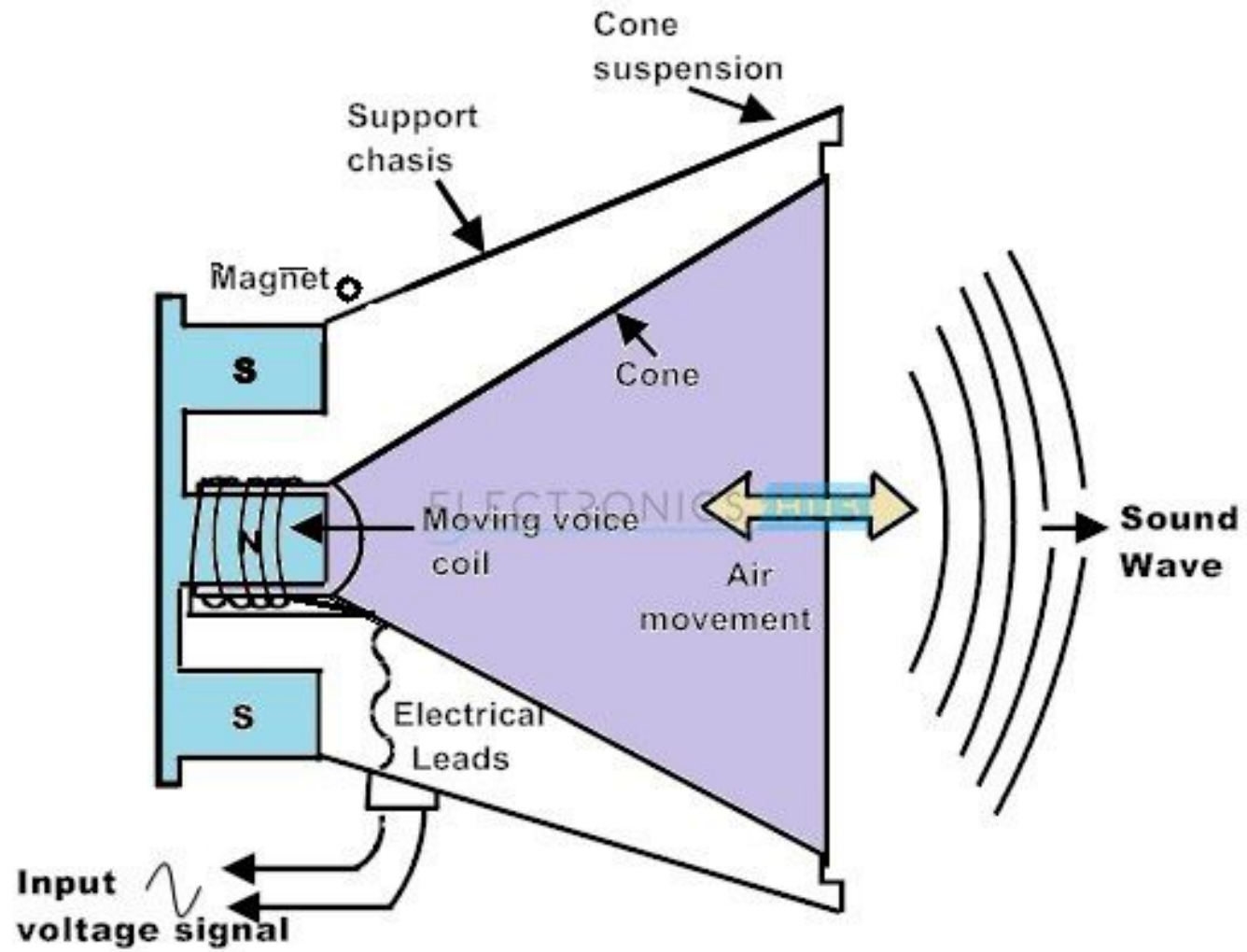

## Sound Transducer | Microphones

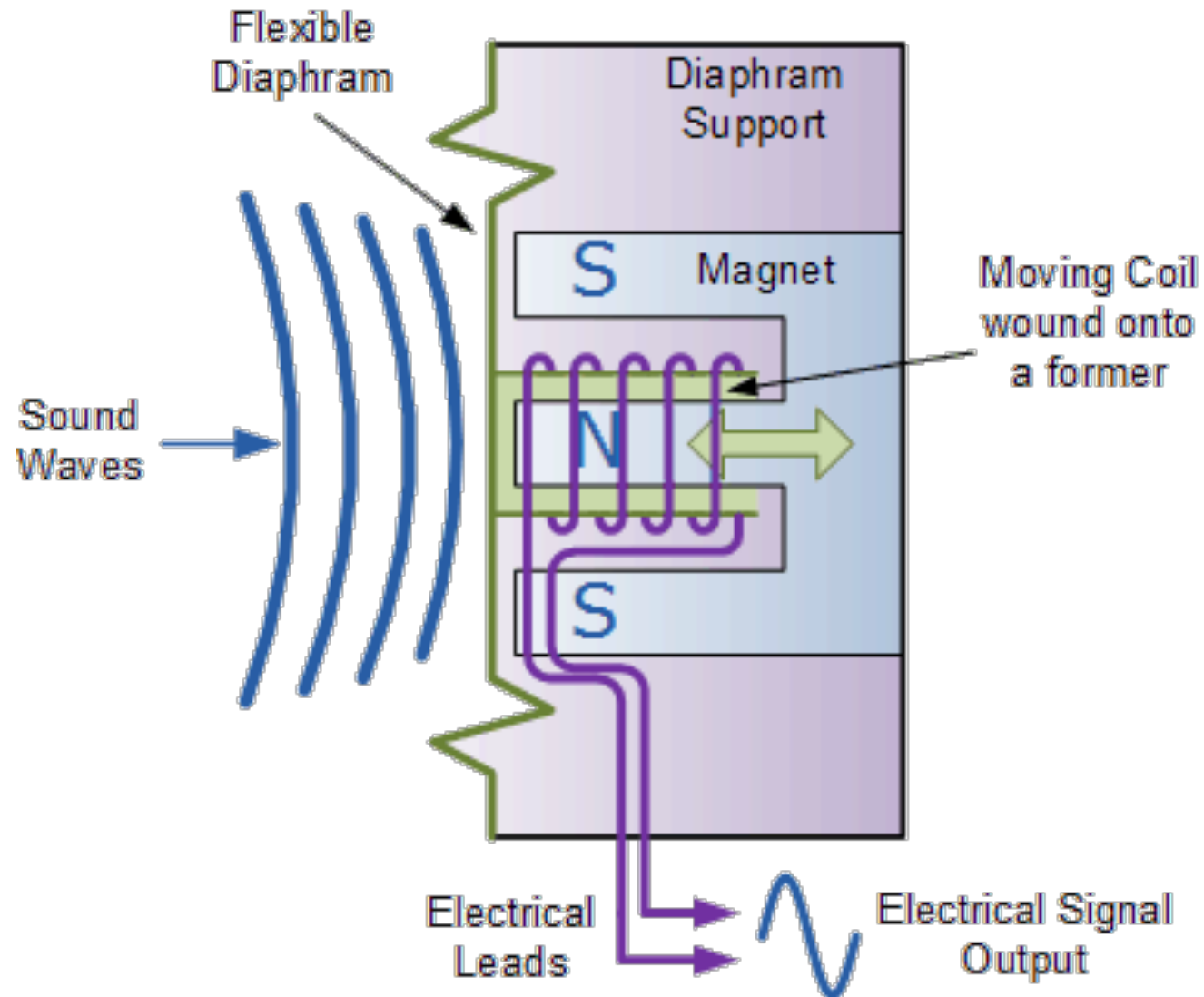

# Electromagnetic Induction (Faraday's Law in Electromagnetic)

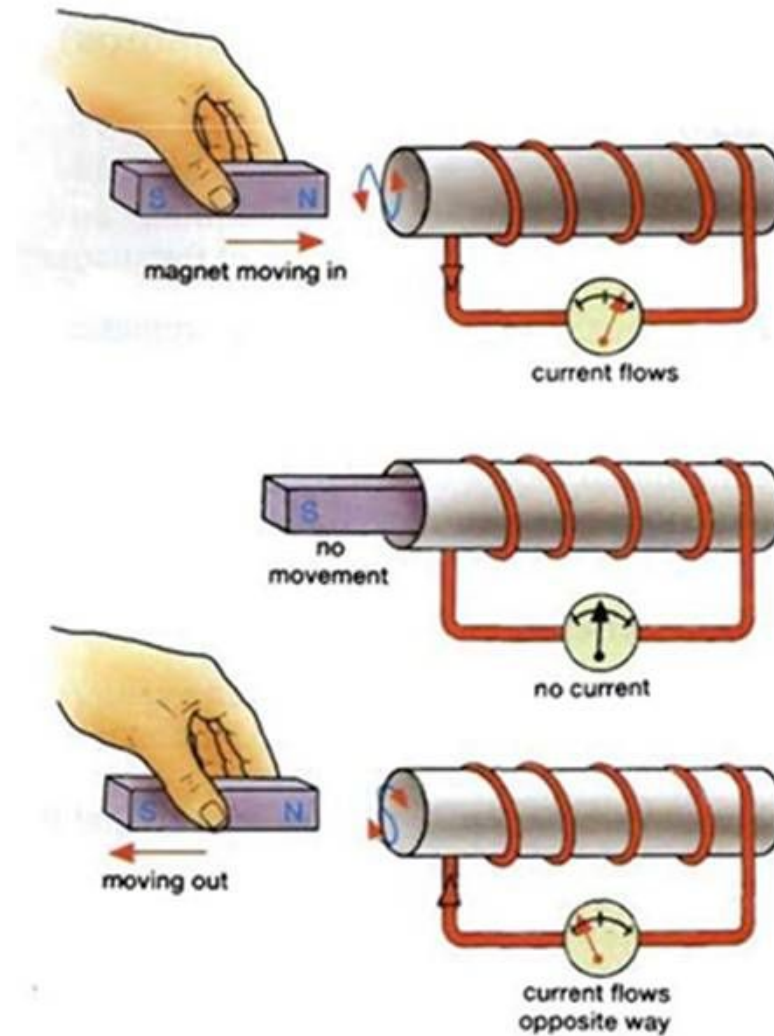

# Electromagnetic Induction (Faraday's Law in Electromagnetic)

## Faraday's Law

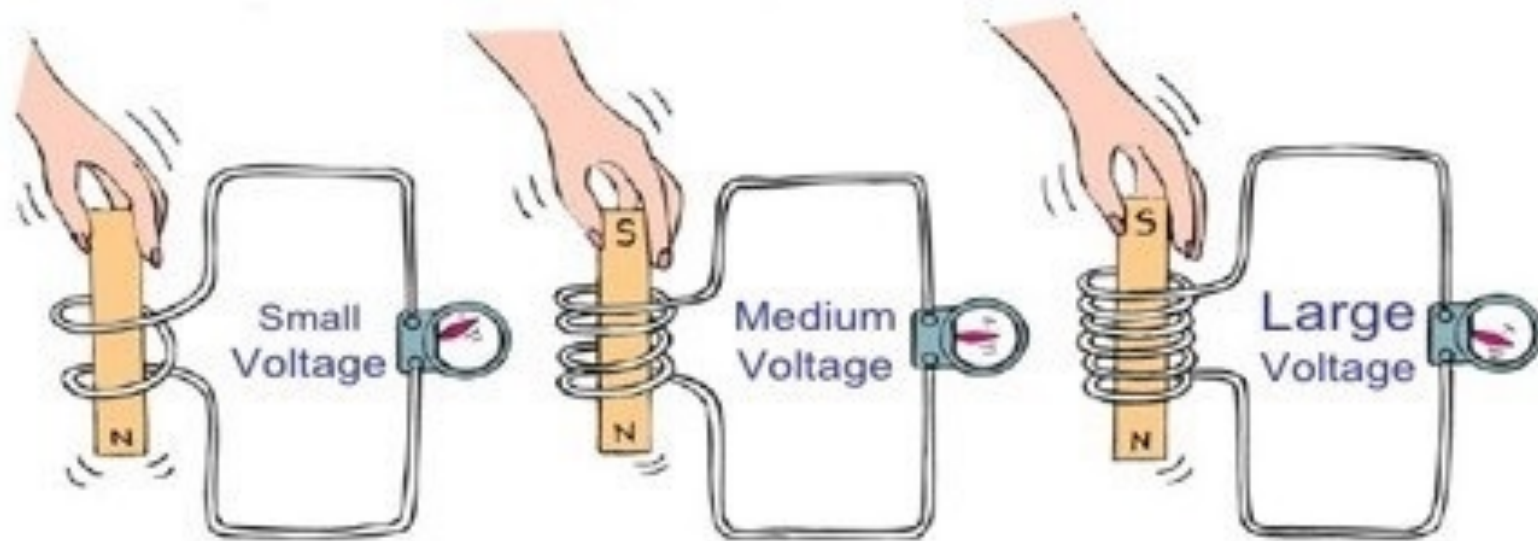

According to Faraday's law in Electromagnetic's, any Conductor moving in a Magnetic Field generates Electricity

# Electromagnetic Induction (Faraday's Law in Electromagnetic)

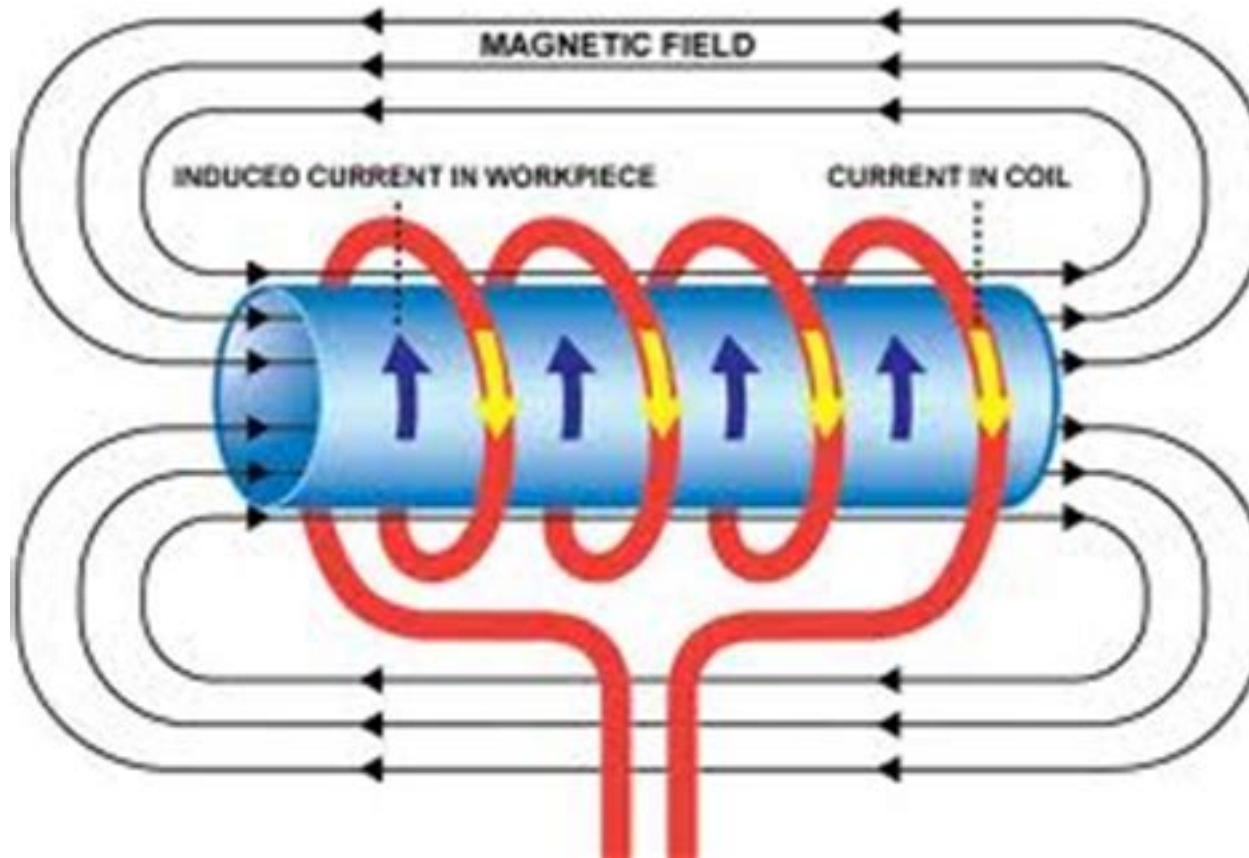

According to Faraday's law in Electromagnetic's, any Electric Current moving into a Conductor in a Magnetic Field or even without a Magnetic Field creates Magnetism.

# SOUND PRESSURE LEVEL OF COMMON ENVIRONMENTAL SOUNDS (dB)

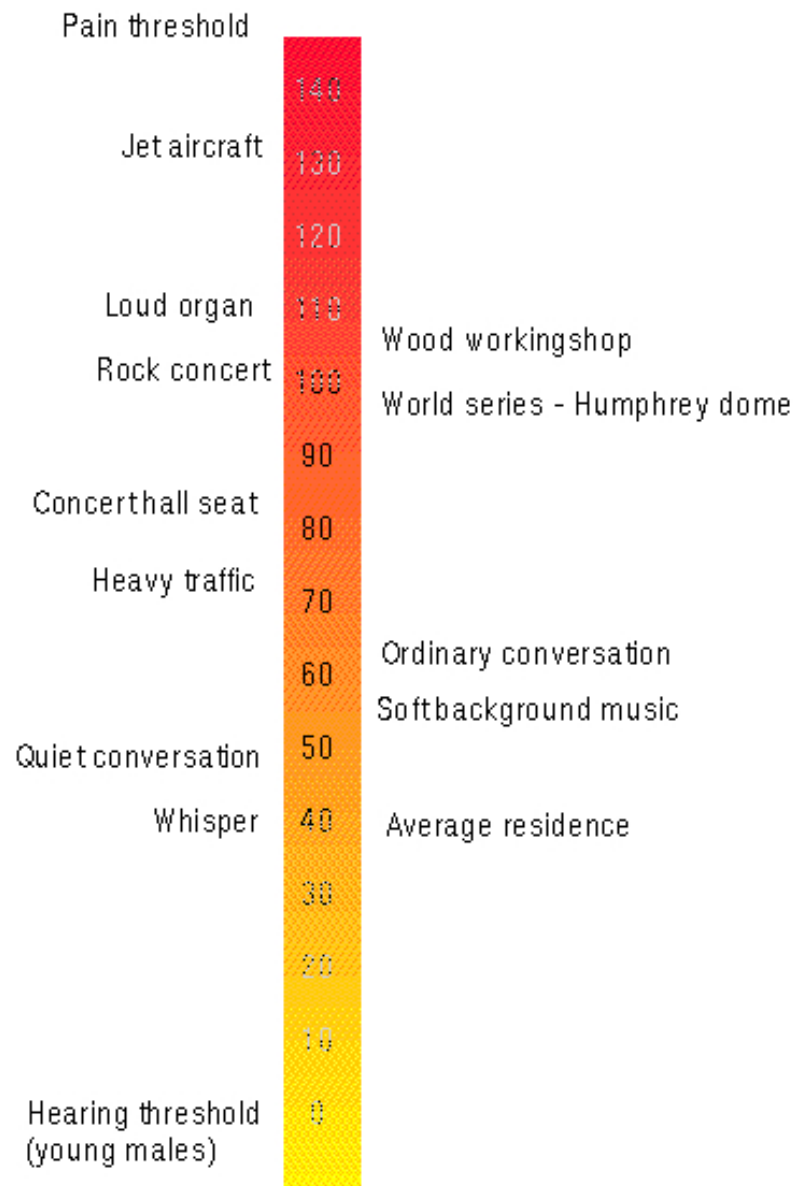

# SOUND PRESSURE LEVEL

*Definition: the local pressure deviation from the ambient (average, or equilibrium) atmospheric pressure caused by a sound wave.*

- ▶ Sound waves are energy produced by vibrating objects
- ▶ The larynx vibrates to produce the voice
- ▶ The vibrations create a pattern, which the ear translates into sound
- ▶ As you double the distance from a noise source loudness decreased by half
- ▶ Strong vibrations from very loud noises can damage the ear

# Sound pressure for known sounds

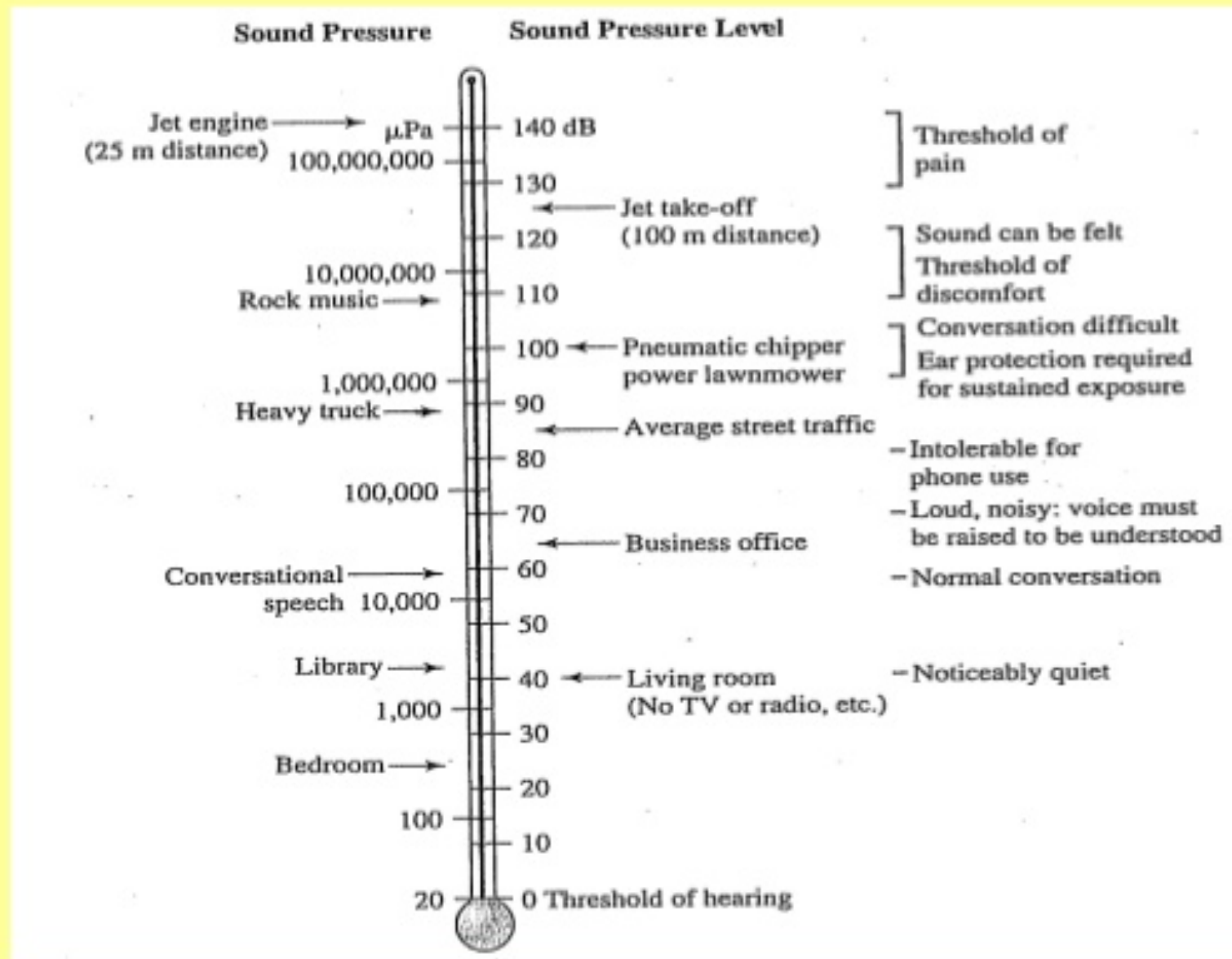

## Why is a Ribbon Microphone also a Dynamic Microphone?

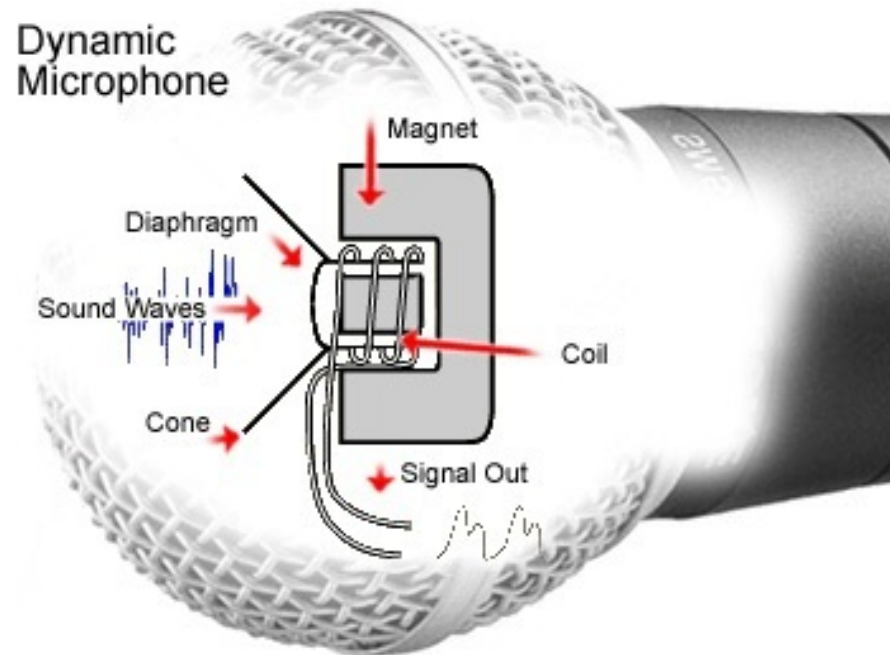

- Because it operates in the same principle as speaker or voice coil microphone
- Because it has a moving conductor in a magnetic field
- Because the motion generated from a sound source or from mechanical signals, will cause the conductor to move inside the magnetic field and it will generate a sound

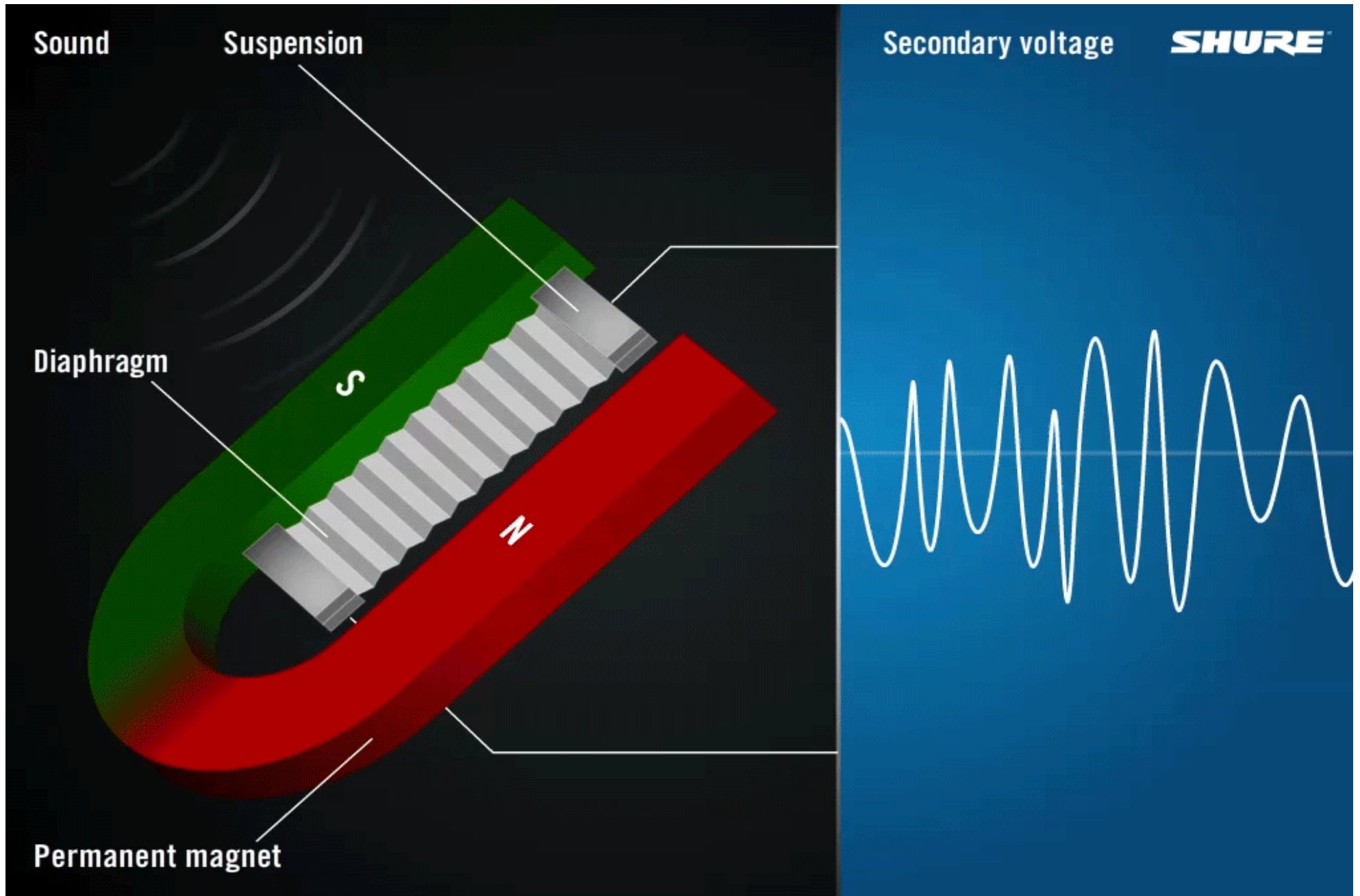

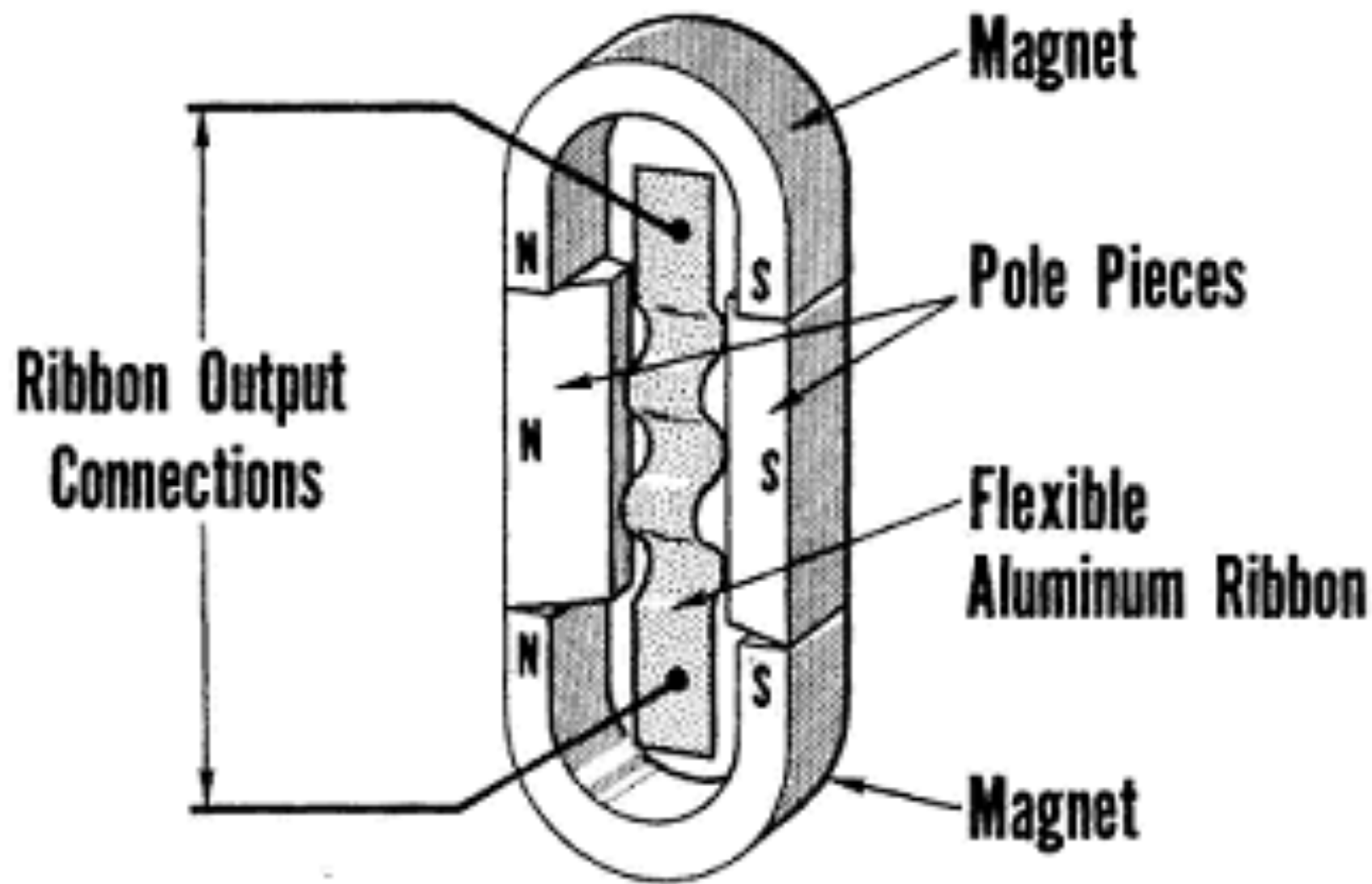

# RIBBON MICROPHONE

# Transformer

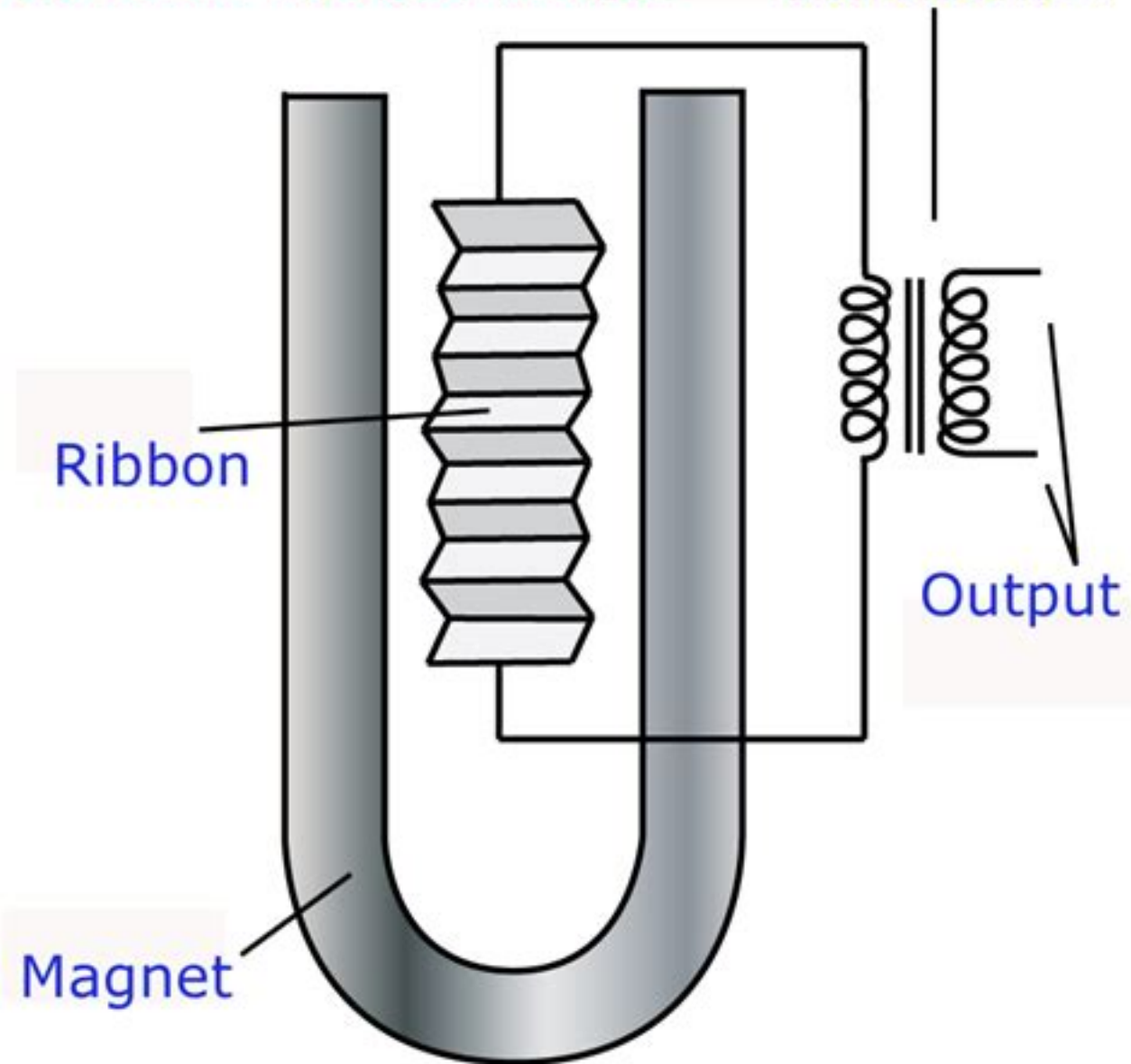

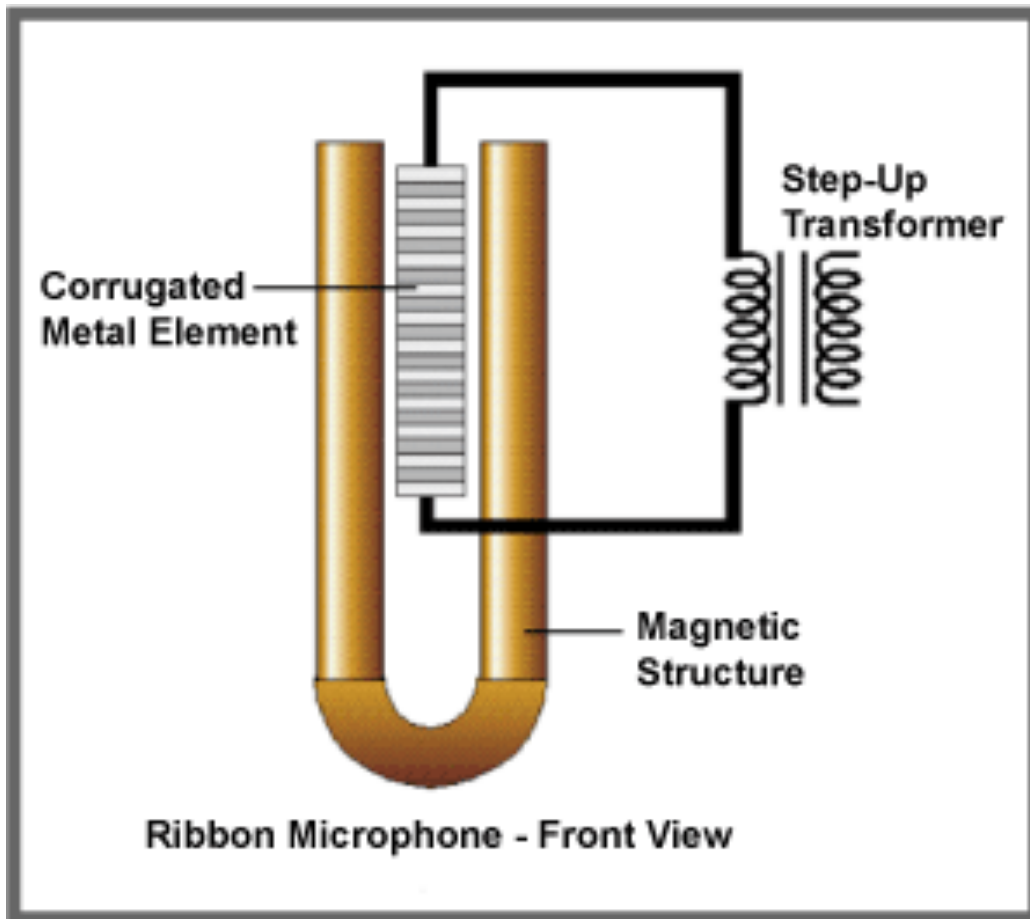

How a ribbon microphone works

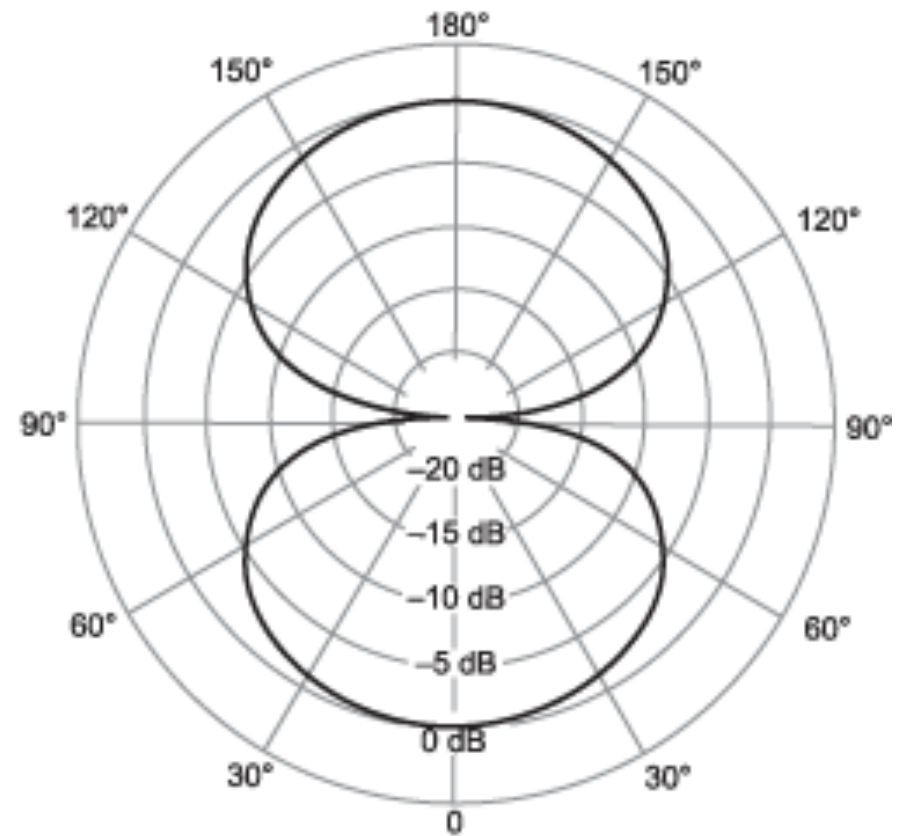

Bi-directional polar or pickup pattern

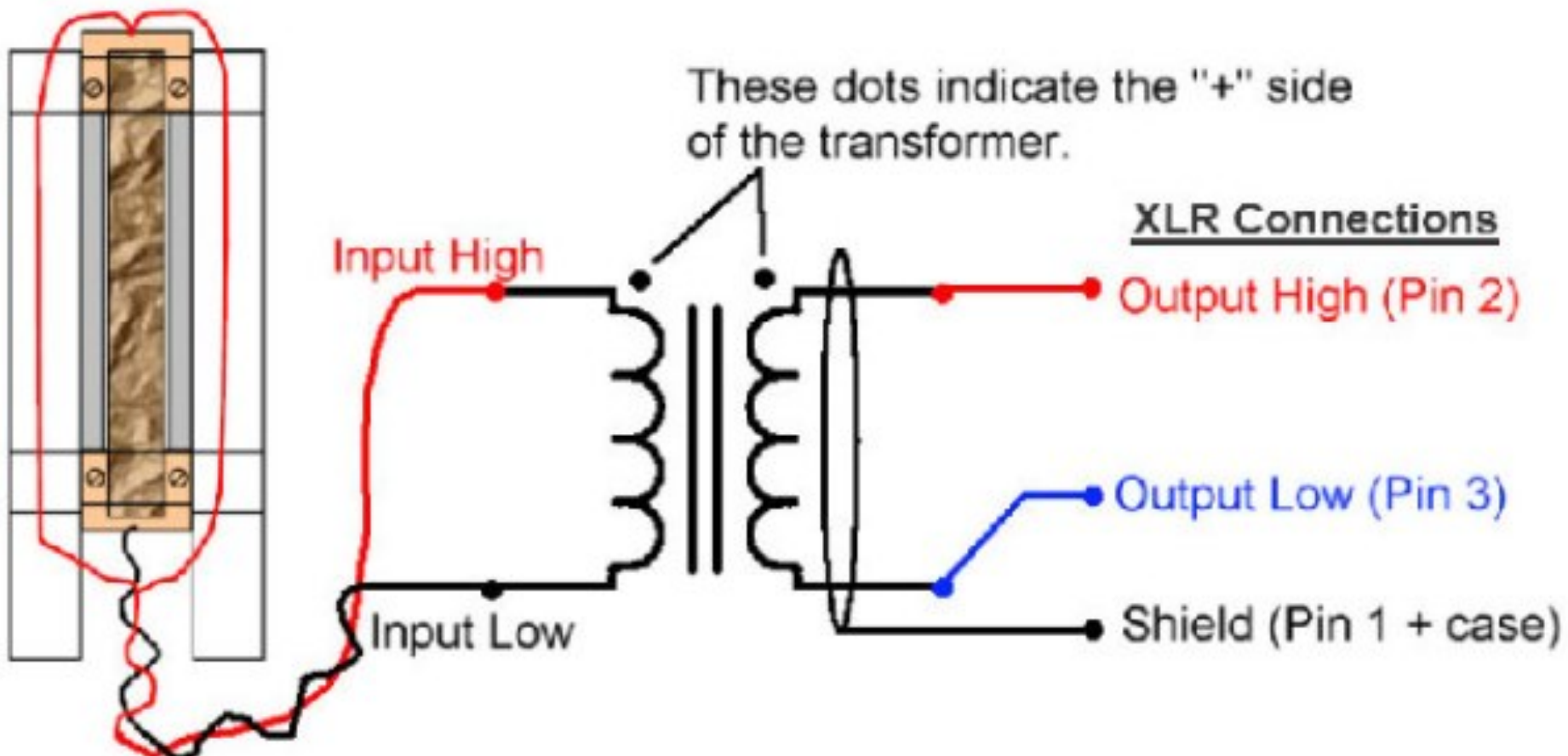

## What Are Microphone Transformers And What Is Their Role?



Some microphones have transformer-coupled outputs while others are deemed transformer-less.

Some microphones even have transformers in the middle of their signal chains rather than at their outputs.

## **What is a microphone transformer?**

A mic transformer is a passive electrical device that physically isolates two circuits while maintaining an electrical relationship between the circuits.

Mic transformers have two conductive coils (one for each circuit) wound around a common magnetic core. They adjust voltage, current, and impedance.

## **What Is A Transformer?**

When we hear the term transformer, we often think of the power transformers that feed electricity to our buildings from power lines. That, or the “robots in disguise.”

The power transformers that provide our buildings with regulated mains voltages deal with much higher voltages and currents than microphone output transformers, but they are both designed on the same principles.

Transformers are passive electromagnetic devices that transfer energy from one circuit to another by means of inductive coupling.

Basically each circuit has its own conductive wire that wraps around a common magnetic core. This effectively couples the two circuits.

Inductively coupled circuits, like those in transformers, are configured so a change in current through one circuit's conductors induces a voltage across the ends of the other circuit's conductor.

The most simple transformers, which are common in transformer-coupled microphones, are made of two circuits. Each circuit has a conductive wire, known as a winding, that wraps around the magnetic core of the transformer.

Typically, the primary winding connects to the circuit that features the microphone capsule's output signal while the secondary winding connects to the output circuit of the microphone.

Here is a simple diagram of a transformer:

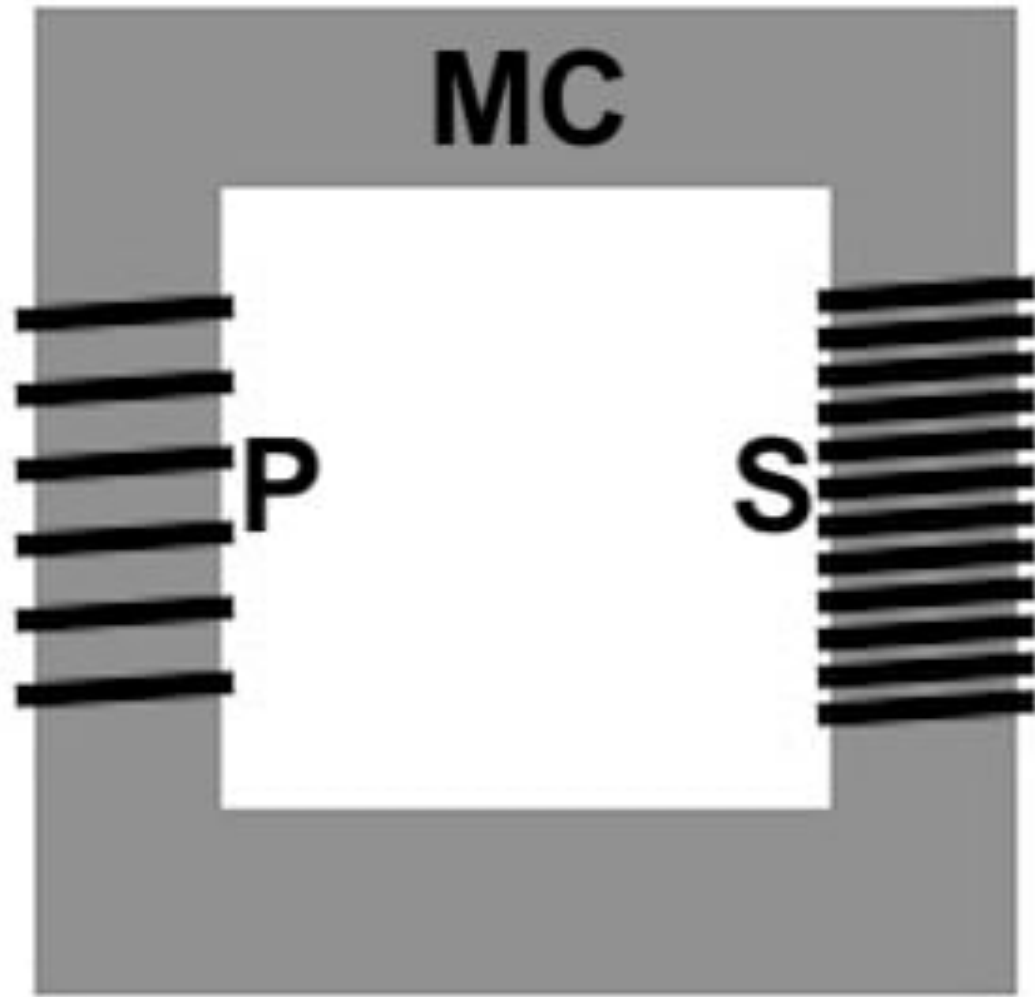

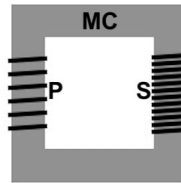

- P = primary winding: the primary winding is on the side of the mic capsule. This does not necessarily mean it is in the same circuit as the mic capsule. Rather, it means that the winding is between the transformer and the capsule rather than between the transformer and the mic output. The primary winding can be thought of as the “input” of the transformer, bringing the mic signal from the capsule to the transformer.
- S = secondary winding: the secondary winding is on the side of the mic output. This means the winding is between the transformer and the output rather than between the transformer and the capsule. The secondary winding can be thought of as the “output” of the transformer. As the signal passes through the primary winding, the transformer effectively produces a proportionate but altered signal across the secondary.
- MC = common magnetic core: in order for inductive coupling to work, we need electromagnetic induction. The voltage across the primary winding causes a changing magnetic field within the magnetic core which then induces a voltage across the secondary winding.

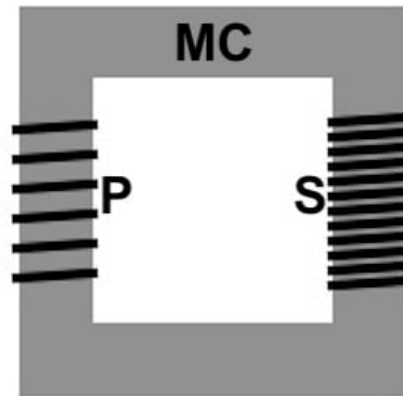

So basically, a voltage across the primary winding (due, ultimately, to the mic capsule) causes a change in the magnetic core's magnetic field. This change in magnetic field then induces a voltage across the secondary winding. This is all due to electromagnetic induction.

Note that transformers only pass alternating current and block direct current. This is known as DC isolation. A direct current is, by definition, not an alternating current. Therefore, it would not produce a changing magnetic field which is necessary for electromagnetic induction to induce a voltage across the other/secondary winding.

It's also critical to note that power input to the transformer (at the primary) and power output from the transformer (at the secondary) is the same (except for conversion losses). I'll repeat this later when we discuss step-up transformers, step-down transformers, and the roles of transformers in microphones.

The Operating Principle of the Ribbon Microphone is different from regular Dynamic Microphone because the ribbon is connected in a short circuit manner, therefore needs a step up transformer to make the signal audible

**What is the main purpose of the Step-Up Transformer particularly in a Ribbon Microphone?**

As the Ribbon conductor is thicker than the wire that is connected to, it generates higher current but has lower voltage. As mixers respond better to voltage, the Step-Up transformer will increase the voltage from the primary winding to the secondary winding, making it detectable by a mixer

## Condenser Microphone: Capacitor Microphone

The condenser microphone or capacitor microphone is able to provide high quality audio

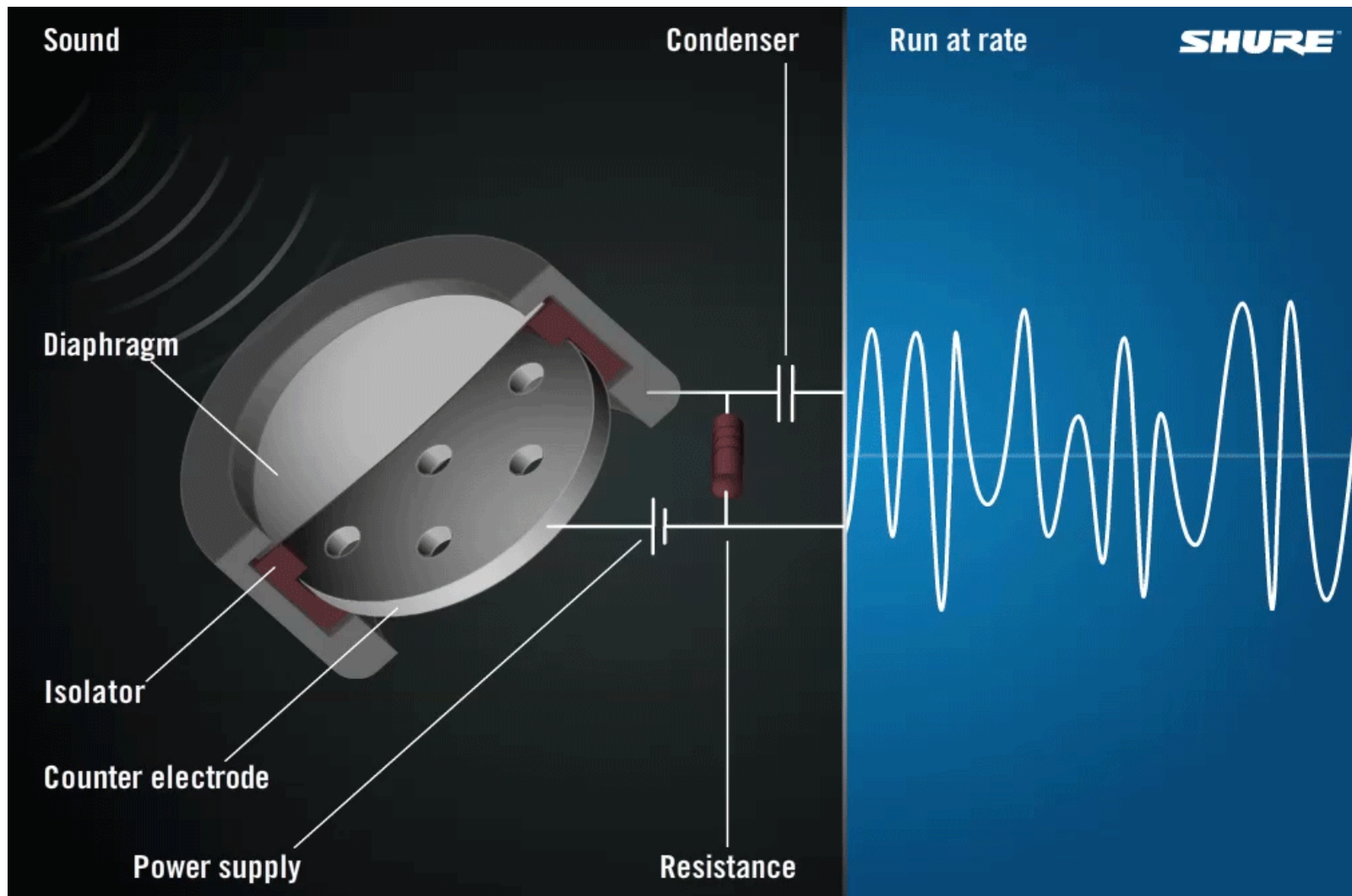

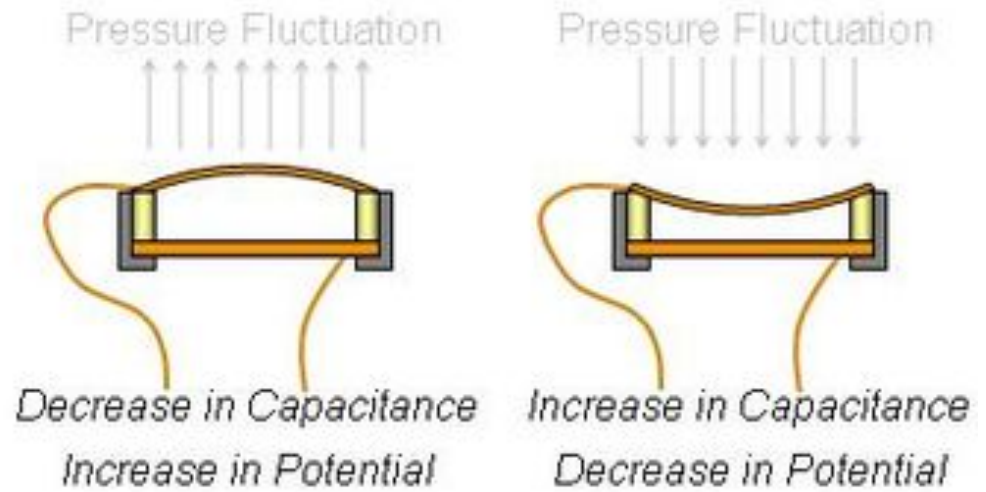
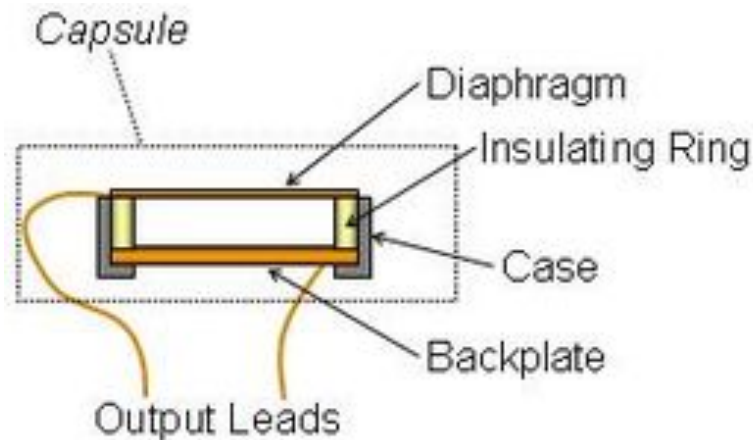

The Condenser Microphone operates on the principle of variable capacitance

With the variation of the placement of the diaphragm, it also varies the capacitance and voltage

Requires phantom power to operate as a permanent charge on the back plate

The diaphragm moving in and out, creates a charge difference corresponding to the sound.

### **What are the Characteristics of a Capacitor?**

Stores energy in the form of an electrostatic field

The charge changes by changing the distance

### **Which two parts make the Capacitor in a condenser Microphone?**

The diaphragm and backplate represent the two plates of the capacitor.

### **Electrostatic Field**

When two objects in each other's vicinity have different electrical charges, an electrostatic field exists between them. An electrostatic field also forms around any single object that is electrically charged with respect to its environment.

## Small Diaphragm Condenser Microphones



- Diaphragm smaller than 1"
- Typically have a very natural and accurate sound to them because their small diaphragm only moves back and forth
- Its diaphragm is generally flat to avoid rotary movements
- Often used on instruments or as measurement microphones

## Large Diaphragm Condenser Microphones



- Diaphragm larger than 1"
- Typical have a warmer and fuller sound
- Diaphragm can make a rotary movements which helps to produce a warmer sound
- Lower Harmonics will generate more movement than higher Harmonics in this type of diaphragm, hence large diaphragm microphones being good to enhance low frequencies
- Excels vocals or acoustics instruments

What is difference in the motion of the Diaphragm between a Dynamic Microphone and a Condenser?

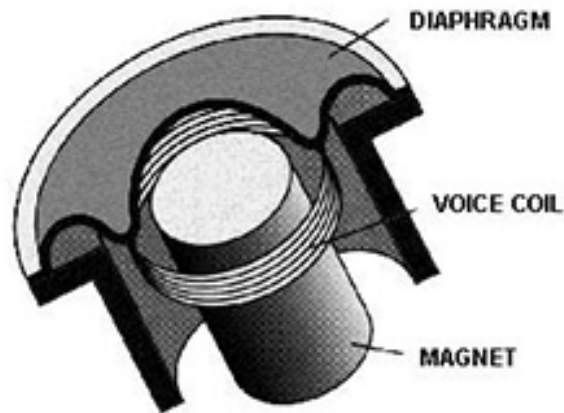

**Dynamic**

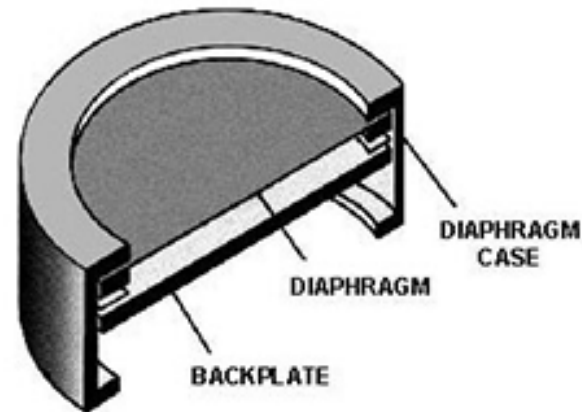

**Condenser**

- Both diaphragms will move In and Out.
- The Dynamic diaphragm will continue to move In and Out a few times before stopping to its default position, whereas the Condenser diaphragm will go back to its default position quicker because it is lighter weight.

**Why is the response of Condenser Microphone in relation to Sound Sources more accurate, and with more detail especially at higher frequencies, than a Dynamic Microphone?**

Condenser Microphone

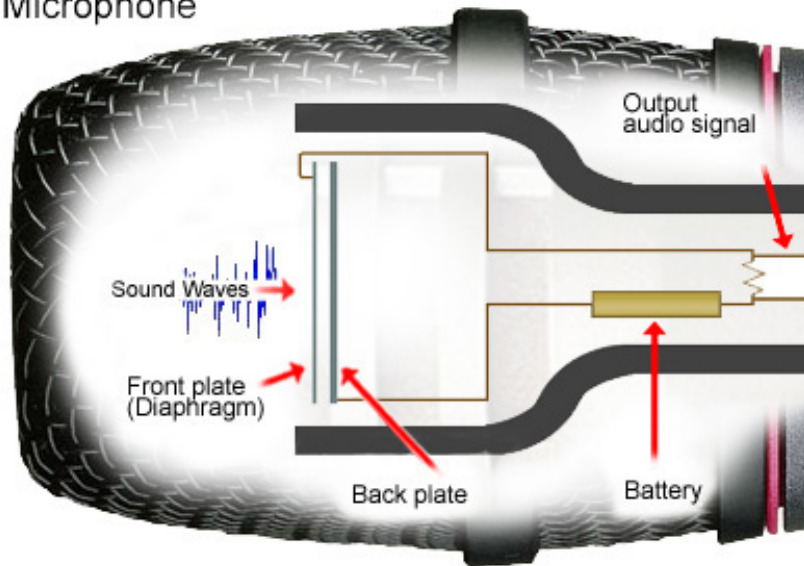

Dynamic Microphone

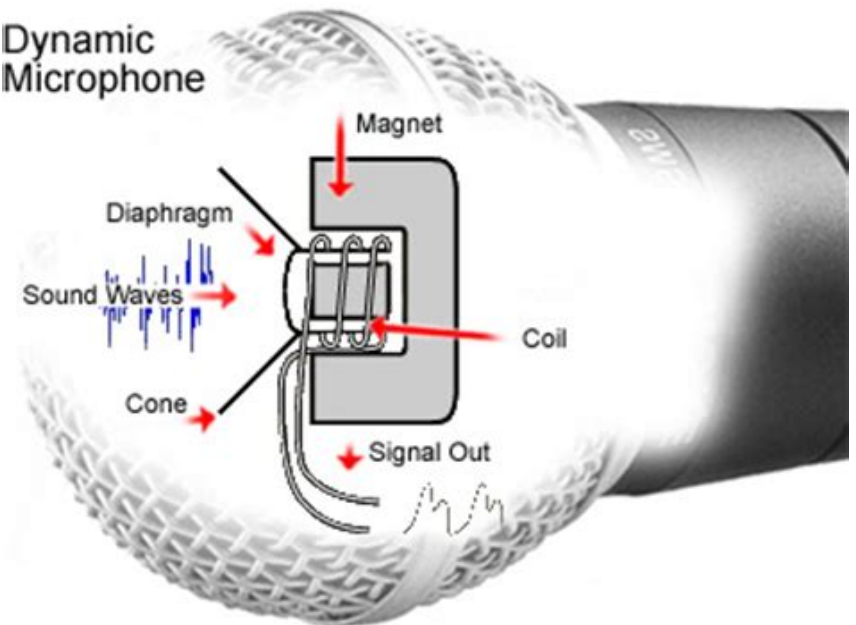

- The diaphragm on a Condenser Microphone defaults to its position quicker because it is lighter, therefore it is more responsive
- The diaphragm on a Dynamic Microphone is heavier and due to its motion, it takes longer to go back to its default position, making it less responsive than a Condenser Microphone
- Condenser Microphones are also more sensitive because they deal with very small electrical charges and have a preamp