

CineIPM-2K



USER'S MANUAL

020-100164-01

China RoHS Compliance Information

关于中国《电子信息产品污染控制管理办法》的说明

- Environmentally Friendly Use Period
环保使用期限



The year number in the centre of the label indicates the Environmentally Friendly Use Period, which is required to mark on the electronic information product sold in China according to the China RoHS regulations.

本标志中表示的年数是根据《电子信息产品污染控制管理办法》（2006年2月28日）以及《电子信息产品污染控制标识要求》（2006年11月6日）制定的、适用于在中华人民共和国境内销售的电子信息产品的环保使用期限。

- Material Concentration Values Table
有毒有害物质含量表

Part Name	部件名称	Material Concentration (有毒有害物质或元素)					
		铅 (Pb)	汞 (Hg)	镉 (Cd)	六价铬 (Cr 6+)	多溴联苯 (PBB)	多溴二联苯醚 (PBDE)
Low voltage power supply	低压电源	X	O	O	O	O	X
Power line filter	滤波电源插口	O	O	O	O	O	O
Harness/cable	连接电线/缆	X	O	O	O	O	X
Ten-bit image processor module	十位图像处理模块	X	O	O	O	O	O
Dual DVI output module	双DVI输出模块	X	O	O	O	O	O
Dual slot backplane module	双槽底板模块	X	O	O	O	O	O
Status display module	状态显示模块	X	O	O	O	O	O
Blower/Fan	吹风机/风扇	O	O	O	O	O	O
Sensor	传感器	O	O	O	O	O	O
Mechanical enclosure*	机械附件	X	O	O	O	O	O
Software CD	软件光盘	O	O	O	O	O	O
Battery	电池	O	O	O	O	O	O
Optional Input Modules	可选输入模块	X	O	O	O	O	O
Remote Keypad	遥控器	X	O	O	O	O	O
Note: O : indicates that the concentration value of the particular hazardous substance contained in all the homogeneous materials for this part, according to EIP-A, EIP-B, EIP-C, is below the stipulated levels in China SJ/T11363-2006. 表示该有毒有害物质在该部件所有均质材料中的含量均在SJ/T11363-2006规定的限量要求以下。 X: indicates that the concentration value of the particular hazardous substance contained in all the homogeneous materials for this part, according to EIP-A, EIP-B, EIP-C, may be above the stipulated levels in China SJ/T11363-2006. 表示该有毒有害物质至少在该部件的某一均质材料中的含量可能超出SJ/T11363-2006规定的限量要求。 * This part uses metallic alloys, which may contain Lead. 因该部件使用金属合金材料，故可能含有铅。							

Table of Contents

	Section	Contents	Page	
1	Introduction	1.1	Description.....	1-1
		1.2	List of Components.....	1-2
		1.3	Purchase Record and Service Contacts.....	1-2
		1.4	Ethernet Settings for This Product.....	1-2
2	Installation & Setup	2.1	Installation	2-1
		2.2	Connecting Sources	2-5
		2.3	Connecting DVI Outputs	2-9
		2.4	Connecting Communications.....	2-11
		2.5	Setting Up the TPC for Source Selection	2-14
		2.6	Linking Multiple <i>Cine-IPM 2Ks</i>	2-15
		2.7	Converting the Keypad.....	2-19
3	Basic Operation	3.1	<i>Cine-IPM 2K</i> Basics	3-1
		3.2	Using the Keypad	3-3
		3.3	Navigating the Menus.....	3-9
		3.4	Using Inputs and Channels	3-13
		3.5	Adjusting the Image.....	3-18
		3.6	Adjusting System Parameters and Advanced Controls	3-32
		3.7	Working with PIP or Seamless Switching.....	3-45
		3.8	Status Menu	3-48
		3.9	<i>Cine-IPM 2K</i> Source Selection via TPC.....	3-48
		3.10	Remote Control of the <i>Cine-IPM 2K</i>	3-49
		3.11	Using Multiple <i>Cine-IPM 2Ks</i>	3-50
		3.12	Error Conditions	3-60
4	Maintenance	4.1	Warnings and Guidelines.....	4-1
		4.2	Maintaining Proper Cooling	4-2
5	Troubleshooting	5.1	Power	5-1
		5.2	Ethernet.....	5-1
		5.3	Displays	5-1
6	Specifications	6.1	Specifications.....	6-1
	Appendices	A	Glossary	A-1
		B	Remote Keypad	B-1
		C	Serial Communication Cables.....	C-1
		D	System Integration.....	D-1
		E	Optional Input Modules	E-1

NOTE: Due to continuing research, all information in this manual is subject to change without notice.

Introduction

1.1 Description

The *Cine-IPM™ 2K* user's manual supports software v1.4e or higher. The *Cine-IPM™ 2K* expands the functionality of Christie's *CP2000 DLP Cinema™* projector by processing a variety of "alternative content" non-cinema signals such as computer graphics, standard-definition video and high-definition video (HDTV) signals. The *Cine-IPM 2K*



Cine-IPM 2K

outputs this RGB data in either 8-bit or 10-bit (selectable) DVI format having 2048 x 1080 display resolution to match that of the *CP2000* (default) or one of 5 other display resolutions. Rack-mount the *Cine-IPM 2K* directly into the projector's pedestal or into a 19-inch equipment rack, or use as a stand-alone tabletop unit.

Main Features ► General

- Choice of five different output resolutions from a variety of sources.
- Versatile electronic scaling to automatically maximize for the display area
- Digital processing selectable as 8-bit or 10-bit, always output through DVI ports
- 3RU enclosure for rack mounting or installation within the *CP2000* pedestal.

4 Standard Inputs, 2 Option Slots

- One analog RGBHV/YPbPr input with 5 BNCs
- One DVI-I input for either digital (RGB/YCrCb) or analog (RGB/YPbPr) signals
- One analog Composite video input
- One analog S-video input
- Built-in multi-standard decoder (NTSC, NTSC 4.43, PAL, PALM, PALN, PAL60, SECAM)
- Two option slots for additional inputs
- Up to 210 MHz pixel rate
- Compatible with all current HDTV formats
- Motion adaptive deinterlacing of 50 fps- and 60 fps-originated standard and high-definition interlaced sources
- Inverse telecine deinterlacing of film-originated standard and high-definition interlaced material with 3:2 pulldown (60 fps) or 2:2 pulldown (50 fps).

Special Display Functions

- Auto setup of non-cinema content
- Electronic brightness uniformity, whitelevel edge blending and color matching
- Optional image warping/blending for unusual angles and/or screens (*ChristieTWIST required*)

Communications and Diagnostics

- Remote keypad, convertible for IR or wired use
- Front IR sensor
- Ethernet, RS232 (with in/out loop-through), RS422 and GPIO control ports
- Built-in ChristieNET™ connectivity for automated operation and source switching
- Interfaces with the *Touch Panel Controller* on the CP2000.
- LCD text display window for status updates and error messages
- Complete log files saved for downloading

1.2 List of Components

The following components comprise a complete *Cine-IPM 2K* (see Figure 3.1):

- Cine-IPM 2K* with pre-installed ears for rack-mounting
- Remote keypad with cable
- Custom RS232 communication cable (*for use with CP2000 only*)
- 3-ft. DVI output cables (2)
- 10-ft. power cord
- 2 rear support screws
- Cine-IPM 2K User's Manual*

1.3 Purchase Record and Service Contacts

Whether this product is still under warranty or the warranty has expired, Christie's highly trained and extensive factory and dealer service network is always available to quickly diagnose and correct malfunctions. Service information is available to service technicians.

Should you encounter a problem with this product and require assistance, please contact your dealer or one of the Christie service depots listed on the back cover of this manual. If you have purchased the product, fill out the form below and keep with your records.

Purchase Record

Dealer:	
Dealer Phone Number:	
<i>Cine-IPM 2K</i> Serial Number:	
Purchase Date:	

* NOTE: Serial number is located on the rear panel of the product.

1.4 Ethernet Settings for This Product

At manufacture, the following Ethernet settings were defined for the *Cine-IPM 2K*:

Factory-set Ethernet Settings for This Product

Default Gateway	n/a
DNS Server	n/a
<i>Cine-IPM 2K</i> Address	0.0.0.0 (<i>DHCP server will auto-assign a valid IP address</i>)
Subnet Mask	255.255.255.0 (fixed)

Installation & Setup

This section explains how to install, connect, and get the *Cine-IPM 2K* up and running. For operating details, refer to *Section 3*.

2.1 Installation

Follow these steps for a quick install of the *Cine-IPM 2K* in the rear of the *CP2000* pedestal.



WARNING

Qualified service technician required.

Step 1 ►

1. Unlock and open the *CP2000* pedestal doors.
2. Remove the 2 rack protector posts from the *CP2000* pedestal rear. Screws are accessed from within the pedestal. See right.

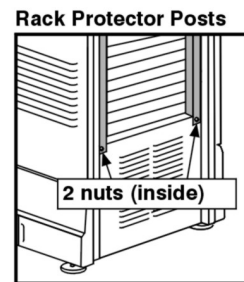
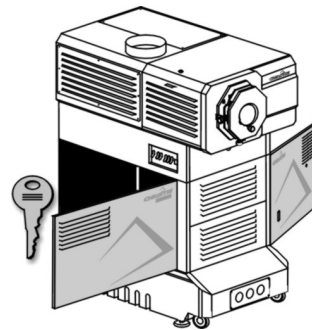
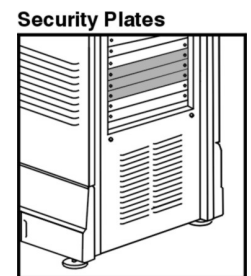

Figure 2.1. Remove Rack Protector Posts (2)

3. Remove 3 security slats to create a 3RU opening for the *Cine-IPM 2K*.



Step 2 ► Install *Cine-IPM 2K*

1. **POSITION EARS AS DESIRED:** To recess the *Cine-IPM 2K* so that its front source connections route through the pedestal and out the front toe, move the *Cine-IPM 2K* mounting ears to their forward position (see Figure



Figure 2.2. To Recess the *Cine-IPM 2K*

2.2). Alternatively, move the ears to their rear mounting location to position the *Cine-IPM 2K* so that its front panel remains accessible and flush with the rear of the *CP2000* pedestal. Always use 4 screws to mount the ears.

2. **INSTALL THE *Cine-IPM 2K*:** Insert the rear of the *Cine-IPM 2K* into the open area of the pedestal. Use 2-4 screws to secure each mounting ear to the pedestal frame.
3. Re-install the 2 rack protector posts.

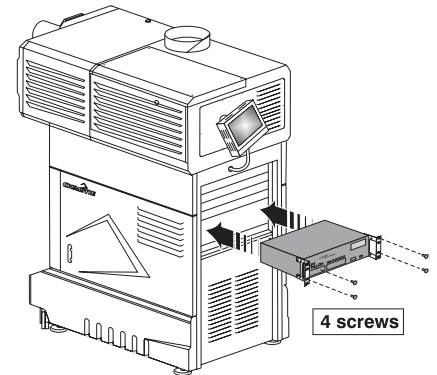

Step 3 ▶ Connect Sources

Connect your desired sources to the appropriate connectors on the front input panel of the *Cine-IPM 2K*. For more information, see 2.2, *Connecting Sources*.

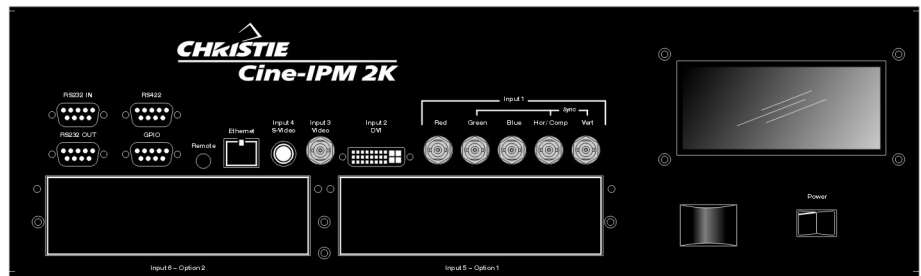

- **INPUT 1** – RGB input or Extra Video* via BNC connectors
- **INPUT 2** – Digital or analog signals (DVI-I) from a computer
- **INPUT 3** – Composite video
- **INPUT 4** – S-video
- **INPUT 5** – optional input module #1
- **INPUT 6** – optional input module #2

NOTE: Extra video is only available with models that have a BNC connector at **INPUT 3 and will not work with previous Christie models, which include a RCA connector at that input.*

In a recessed installation, pass the source cable ends through the ears and down to exit via the front toe of the pedestal, then connect at the source (Figure 2.3).

See the *CP2000 User's Manual* for further cable routing details.

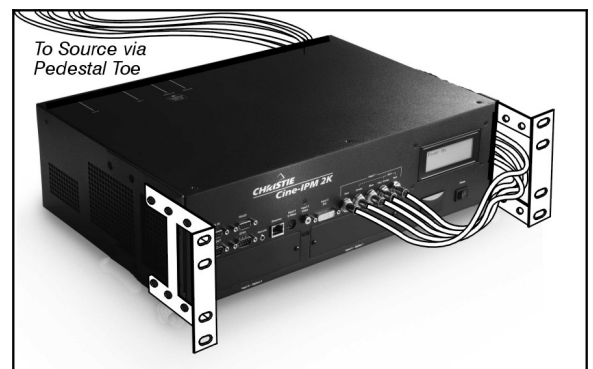

Figure 2.3. Suggested Cable Routing

Step 4 ► Connect DVI Output

TO PROJECTOR: Connect a DVI cable between the **DVI-1** port on the *Cine-IPM 2K* rear panel and the **DVI-1** port on the *CP2000*. See Figure 2.4.

Distance for DVI Output	DVI Cable Required
Up to 3 ft. / 1m	Use DVI cables provided (2)
4 ft. – 16 ft. / 1.25 – 5m	Use a standard DVI cable
Over 16 ft. / 5m	Use a fiber-optic (or similar) cable — Contact Christie

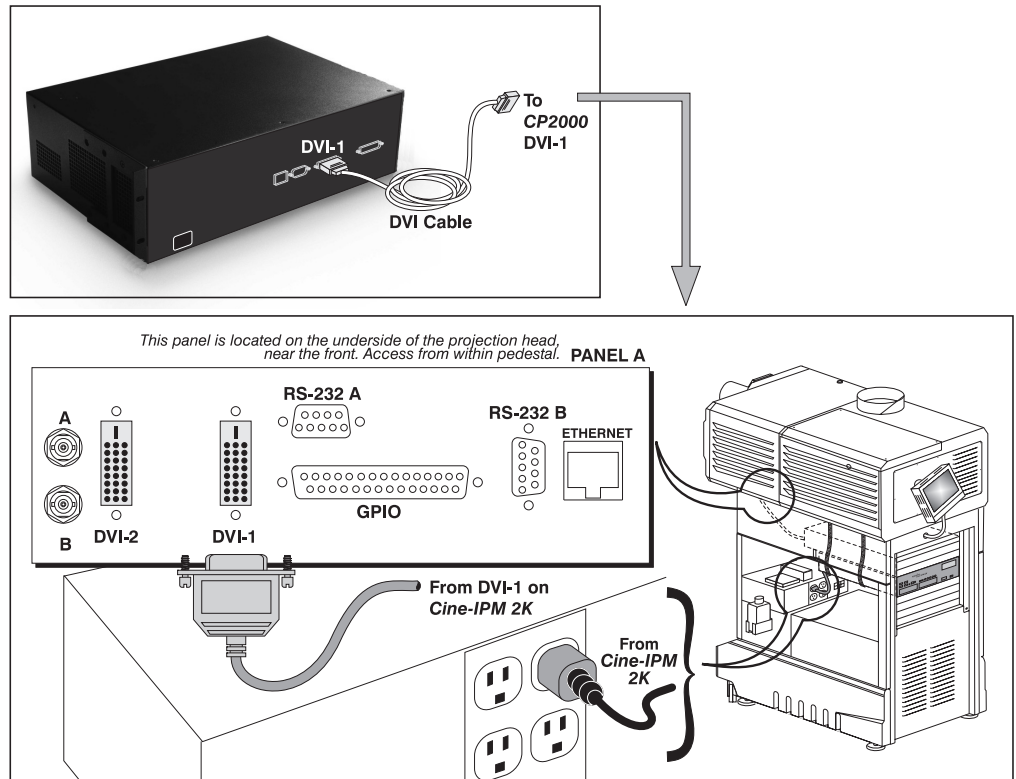

Figure 2.4. Standard DVI Connection for 8-bit Output on the CP2000

TO 2nd DEVICE: To use an additional display device such as a digital monitor or second projector, connect the second DVI cable between **DVI-2** on the *Cine-IPM 2K* rear panel and the extra device (Figure 2.5). Display devices connected to **DVI-2** must accept DVI, i.e. they must be digital—the DVI-VGA adapter is for **DVI-1** use only. In addition, the device must accept the *Cine-IPM 2K* format selected.

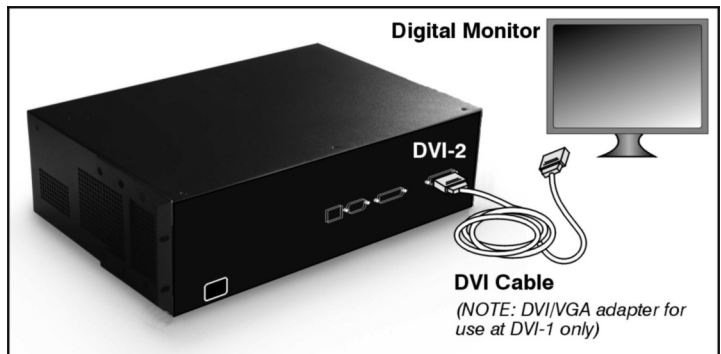

Figure 2.5. Adding a 2nd Display Device

NOTES: 1) Based on some monitor resolution limitations, Cine-IPM 2K output may not be accepted. 2) For any installation, connect either DVI-1 or DVI-2 to a compatible display device; output data is the same until 10-bit mode is activated. 3) For complete information, such as how to connect for 10-bit operation, see 2.3, Connecting DVI Outputs.

Step 5 ► Connect Communications

All Cine-IPM 2K functions can be accessed and controlled using its keypad. Use the keypad as an IR remote, or connect it to the Cine-IPM 2K's front input panel using the keypad cable (wired configuration is required when the Cine-IPM 2K is permanently hidden within the pedestal).



For the option of using the CP2000's Touch Panel Controller to select Cine-IPM 2K sources, you must also connect the Cine-IPM 2K's RS232 "B" cable (see right):

1. Connect the custom RS232 cable (provided) to the **RS232 B** port on rear of the Cine-IPM 2K.
2. Connect the other end to the **RS232 B** port on the CP2000. Refer back to Figure 2.4.

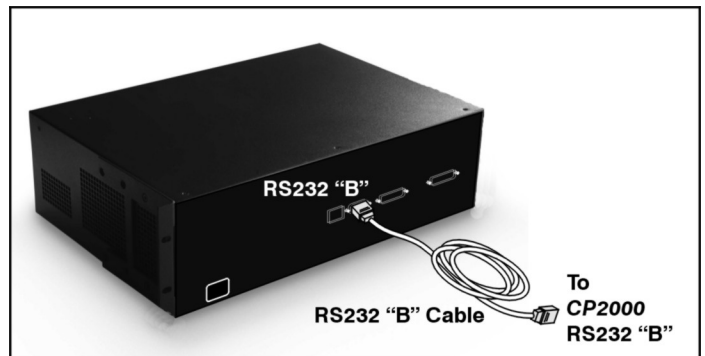

Figure 2.6. Connecting Communication to TPC



IMPORTANT
Do not use RS232 "B" ports and cable with other equipment or in other configurations.

STEP 6 ► Connect to Power

Connect the Cine-IPM 2K power cord to the convenience outlet within the pedestal (refer back to Figure 2.4), or to an external supply as desired. See *Specifications* for power requirements.



WARNING
Do not attempt operation if the AC level is not within the specified range for the Cine-IPM 2K.

STEP 7 ► Turn on the Projector

Follow the complete power-up instructions provided in the *CP2000 User's Manual*.

STEP 8 ► Turn on the Cine-IPM 2K

At the front of the Cine-IPM 2K, set the "Power" switch to **ON**. Then press  (power) on the remote keypad.

STEP 9 ▶ Select a Source

Using the remote keypad, press **Input 1**, **Input 2**, **Input 3**, **Input 4**, **Input 5** or **Input 6** to select the corresponding source connected in Step 3. The image from this source will be projected as a 2048 x 1080 display (default).

If desired, an installer, administrator or advanced user can configure the TPC for *Cine-IPM 2K* source switching—see 2.5, *Setting Up the TPC for Source Selection*.

Press **Auto Setup** and/or **Menu** to refine other display parameters for this source as desired, or to change to 10-bit output and/or a different resolution. See also 3.4, *Using Inputs and Channels*.

STEP 10 ▶ Close/Lock Pedestal Doors

With the *Cine-IPM 2K* fully installed, you should need no further access to the interior of the pedestal. In a recessed installation where the *Cine-IPM 2K* is inaccessible, make sure to leave the *Cine-IPM 2K* main switch permanently set to “on”.

2.2 Connecting Sources

Sources connect to the front panel of the *Cine-IPM 2K*. See Figure 2.7. To add a source when the *Cine-IPM 2K* is recessed and secured within the *CP2000*, a qualified service technician must unlock and open the pedestal for access.

Input Panel

The upper right corner (**INPUT 1**) typically accepts an *RGB signal* from an external analog RGB source, or it can also be used for YPbPr signals. Adjacent to these BNCs, the DVI-I connector (**INPUT 2**) accepts digital or analog display signals from a computer. Connect analog *composite video* at **INPUT 3** or *S-video* at **INPUT 4** from devices such as VCRs, laser disk players or DVD players.

USING THE OPTIONAL SLOTS: There are also several optional interfaces available for connecting additional sources. These interfaces slide into the option slots #1 (**INPUT 5**) or #2 (**INPUT 6**), and may be removed or installed while the *Cine-IPM 2K* is powered up, if desired. Insert carefully along installation guides, making sure not to touch the main board installed near the roof of the open slot.

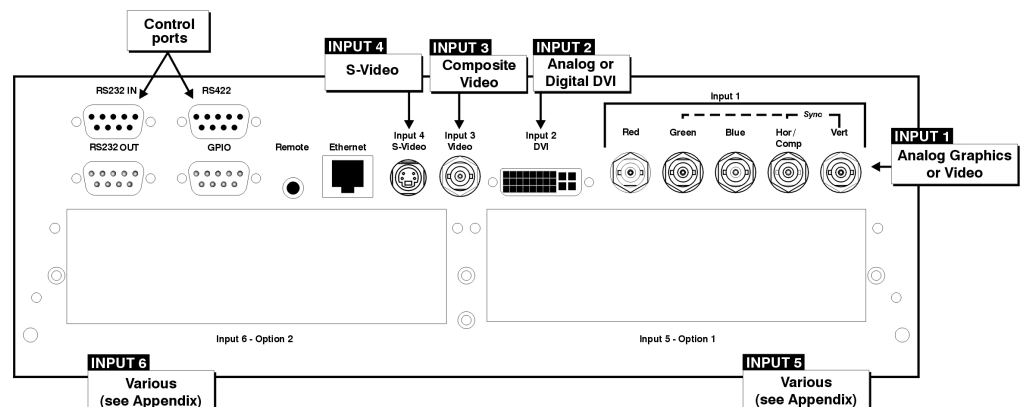

Figure 2.7. Cine-IPM 2K Input Panel

NOTES: 1) See *Section 6, Specifications* for details regarding compatible inputs. 2) For all connections, use high quality shielded cables only.

RGB Signals ► **INPUT 1** consists of 5 BNCs (connectors) for linking to a variety of sources. The typical connection would be to an RGB source such as a PC, Mac, DEC, Sun, SGI and others. The *Cine-IPM 2K* supports multiple sync types with RGB signals: sync-on-green, composite sync, and separate H & V syncs.

NOTE: Depending on your source, you may need a custom adapter cable with BNC connectors at the projector end and a different type of connector at the other (such as a 15-pin "D" connector for some computer sources). Contact your dealer for details.

Connect the **SYNC** BNC input(s). Then connect the red, green and blue source outputs to the **RED**, **GREEN**, and **BLUE** BNCs on the **INPUT 1** panel. If the source uses sync-on-green, only the red, green, and blue connections are required. If the source provides a composite sync output, connect it to the **SYNC** input labeled **HOR/COMP**. If the source provides separate horizontal and vertical sync outputs, connect horizontal sync to the **SYNC** input labeled **HOR/COMP** and connect vertical sync to **SYNC** input labeled **VERT**. See Figure 2.8.

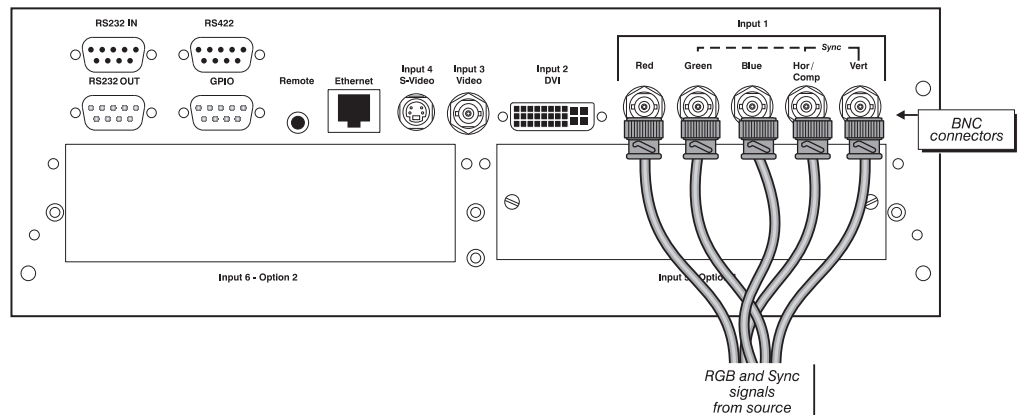

Figure 2.8. Connecting an RGB source

*NOTES: 1) If for some reason the projector fails to recognize a signal as an RGB signal, specify this **Color Space** option within the **Image Settings** menu. See 3.5, **Adjusting the Image**. 2) To connect YPbPr signals—such as from DVDs or analog HDTV sources—to **INPUT 1**, use the red, green and blue BNCs as described in **YPbPr Signals** (below). 3) This input does not route to the decoder and cannot be used for Composite Video or S-Video.*

YPbPr Signals (COMPONENT VIDEO) ► Connect a YPbPr signal (*component video*) to **INPUT 1** or **INPUT 2** as shown in Figure 2.9.

*NOTES: 1) If, for some reason, the projector fails to recognize a YPbPr signal, specify this **Color Space** option within the **Image Settings** menu. See 3.5, **Adjusting the Image**. 2) Do not connect digital component signals (known as YCbCr) to **INPUT 1** or **INPUT 2**. Use the appropriate optional digital interface installed in **INPUT 5** or **6** only. 3) With v1.1 software, digitally encrypted source material (HDCP) cannot be processed and will be displayed as a blank screen.*

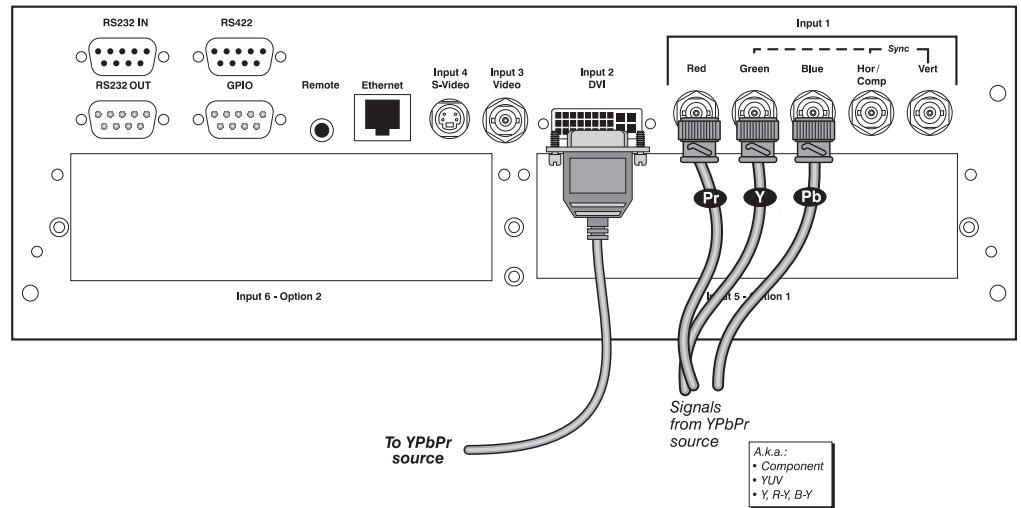

Figure 2.9. Connecting a YPbPr Source

Video ► **INPUT 3** and **INPUT 4** provide simultaneous connection of both a composite video source (**INPUT 3**) and an S-Video source (**INPUT 4**). See Figure 2.10.

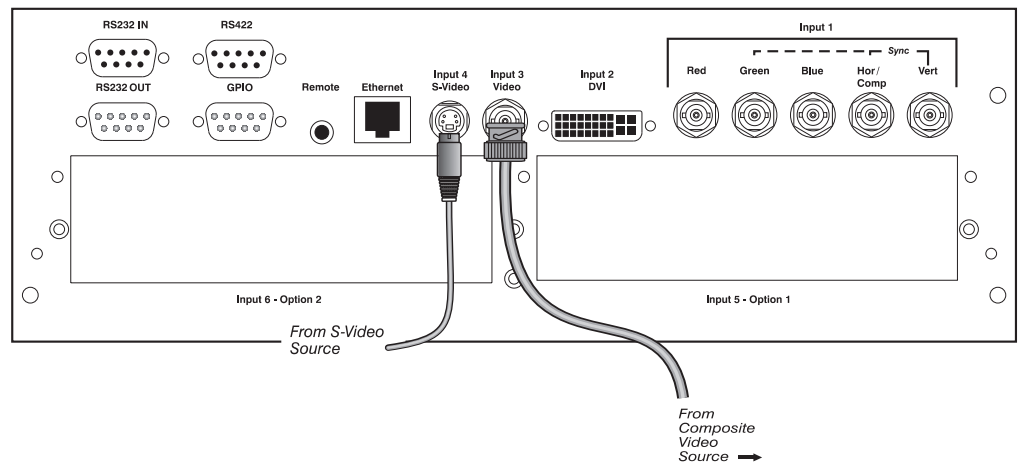

Figure 2.10. Connecting Composite Video and/or S-Video

Extra Video ► If you want to use an extra video source in addition to the video source(s) connected at **INPUT 3** or **INPUT 4** connect either a Composite or S-video source to **INPUT 1** as shown.

NOTES: 1) Do not simultaneously connect Composite and S-video to INPUT 1. 2) You can switch between video sources connected at INPUT 1 and INPUT 3 or INPUT 4. 3) Extra video is only available with models that have a BNC connector at INPUT 3 and will not work with previous Christie models, which include a RCA connector at INPUT 3.

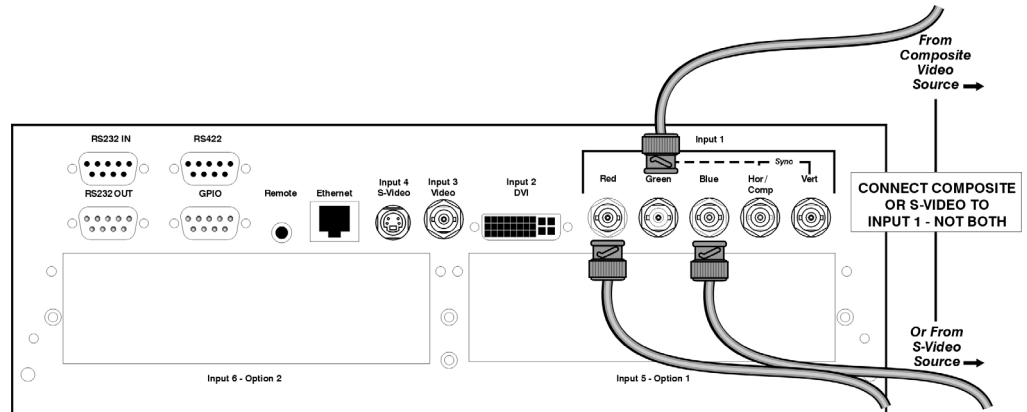

Figure 2.11. Connecting an Extra Video Source to Input 1

Optional Inputs ► Optional input modules allow you to increase your total number of inputs and/or accommodate different signal types, whether analog or digital. Install in the areas labeled **INPUT 5** or **INPUT 6**. These interfaces include:

- RGB 500 Input Module
- RGB 400 Active Loop Thru Input Module
- RGB 400 Buffered Amplifier Input Module
- PC250 Analog Input Module
- Serial Digital Input Module
- Digital HDTV Module
- DVI Input Module
- Dual SD/HD-SDI Module

For even more sources, connect a 3rd-party switcher to the RS232 IN port, or, if RS422-compatible, to any of the three RS422 ports. Note that any sources in a switcher can be selected only at the switcher, not via the keypad or TPC.

*NOTES: 1) Connect analog HDTV signals directly to **INPUT 1** or to any other “RGB” input module installed—the optional HDTV Input Module used in earlier projectors is not needed or recommended. 2) See **Appendix E, Optional Input Modules** for a brief description of each interface.*

2.3 Connecting DVI Outputs

All input signals processed by the *Cine-IPM 2K* are routed to the identical DVI outputs located on the rear panel of the unit. Connect **DVI-1** to the **DVI-1** connector on the *CP2000* (cable provided). If desired, connect an additional display device such as a digital monitor using **DVI-2**. Shown are 4 typical applications for the *Cine-IPM 2K*:

- 8-bit mode for one *CP2000* (Figure 2.12A)
- 8-bit mode for *CP2000* and a digital monitor (Figure 2.12B)
- 8-bit mode for two *CP2000*s (Figure 2.12C)
- 8-bit or 10-bit mode for one *CP2000* (Figure 2.12D)

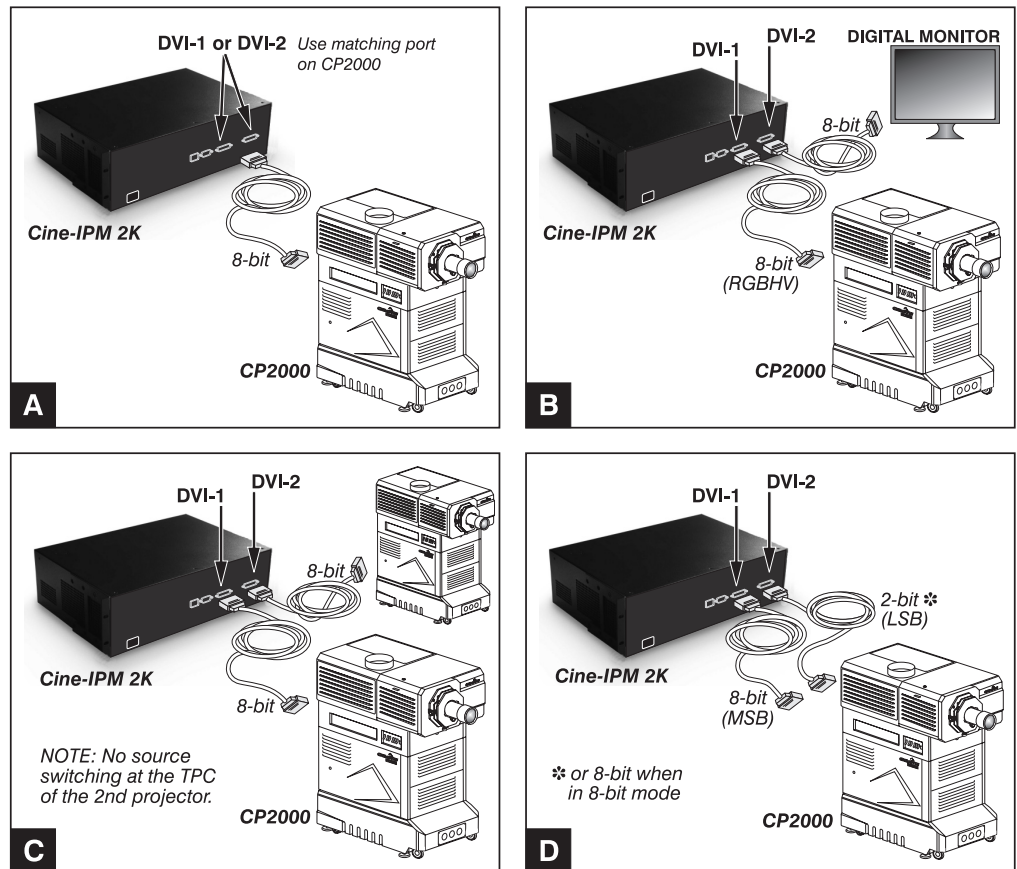

Figure 2.12. Connecting for 8-bit vs. 10-bit Use

Connecting for 10-bit Use

If desired, such as when you have digital progressive source data, you can output it in 10-bit format for a single *CP2000* connected to the *Cine-IPM 2K*. This is shown in Figure 2.12D above. Because *Cine-IPM 2K*'s 10-bit output is divided between the two DVI ports, with **DVI-1** handling the most-significant 8 bits and **DVI-2** handling the remaining least-significant 2 bits, 10-bit mode requires *both* outputs connected to the corresponding *CP2000* DVI ports.

Selecting 8-bit or 10-bit Mode

With the Figure 2.12D configuration, you can use either 8-bit or 10-bit *Cine-IPM 2K* mode for all sources. Make sure to set this mode (a.k.a. "Data Format") in 2 places:

1. ***In the Cine-IPM 2K*** Configuration menu, select the *Output Format* submenu.
2. Select the desired “Output Format”— use “Single Link 8-bit” or “Twin Link 10-bit”. The latter improves displays of digital progressive source data.

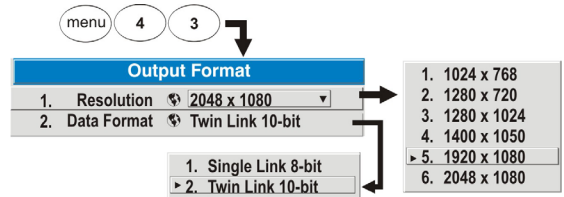
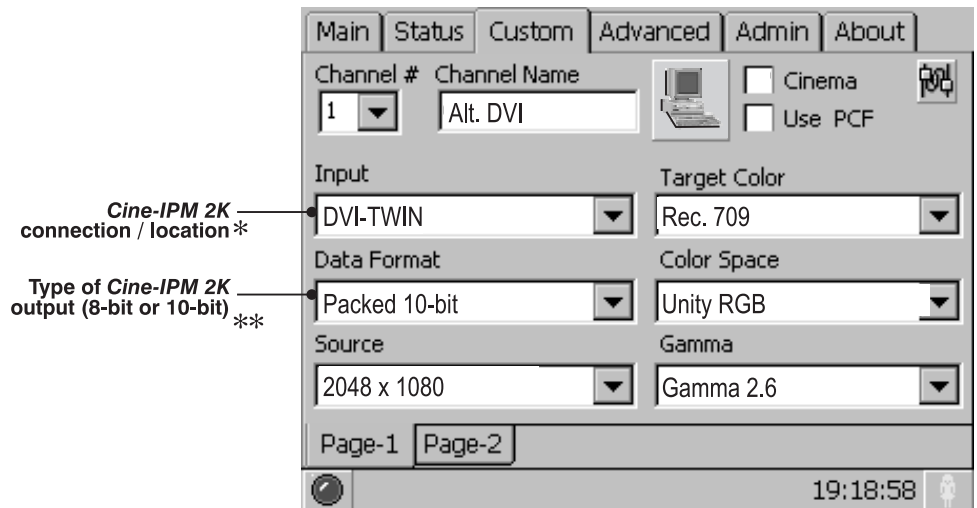

Figure 2.13

The *Cine-IPM 2K* outputs all sources according to the choice set here.

3. ***In the TPC***, go to the *Custom* menu (password required). Set “Input” to the current DVI route:
 - ❑ For 8-bit mode via a DVI-1 connection, select “DVI-A”
 - ❑ For 8-bit mode via a DVI-2 connection, select “DVI-B”.
 - ❑ For 10-bit mode via a double connection, select “DVI-TWIN”.



*Set to match type of Cine-IPM 2K’s DVI connection to CP2000 (1=A, 2=B)
 **Set to match current Cine-IPM 2K output

Figure 2.14. TPC Settings (10-BIT EXAMPLE)

4. Still in the TPC *Custom* menu, set “Data Format” to match the *Cine-IPM 2K* format chosen in Step 2.

NOTE: When using the *Cine-IPM 2K* with two display devices, both outputs are 8-bit duplicates of one another and 10-bit mode is not available.

For complete setup information and control of other *Cine-IPM 2K* options such as resolution, refer to 2.5, *Setting Up the TPC for Source Selection*. See also Section 3.

2.4 Connecting Communications

As an alternative to keypad and/or TPC control, you may wish to communicate with the *Cine-IPM 2K* using a PC or other controller. Such a device sends commands and receives feedback via serial links (2 types), Ethernet or GPIO communications. All types of communication methods are described below.

Remote Keypads ▶ If desired, connect a wired (tethered) version of the *Cine-IPM 2K* remote keypad to the 3.5mm phono jack on the front panel. Note that response to a wired keypad must also be enabled in the *Communications* menu—see 2.7, *Converting the Keypad* for more information.



TPC ▶ If you have connected the rear RS232 “B” port of the *Cine-IPM 2K* to the RS232 “B” port in the *CP2000*, you can use the *Touch Panel Controller* for selecting sources connected to the *Cine-IPM 2K*. Refer back to Figure 2.6. The RS232 connection also enables *Cine-IPM 2K* status updates at the TPC.



NOTE: The TPC can select a specific Cine-IPM 2K source (#1-6) only if the CP2000 is connected via DVI-1. If connected via DVI-2, the TPC can select this port (called DVI-B), but you must use the Cine-IPM 2K keypad to select the source (#1-6).

The rear Ethernet port on the *Cine-IPM 2K* is an alternative route planned for TPC communications, but is currently non-functional.



Other Controllers ▶ RS232 Serial Communications

From most computers, connect a standard RS232 serial communication cable between the computer and the *Cine-IPM 2K* serial port labeled **RS232 IN**. Then set the *Cine-IPM 2K* baud rate to match that of your computer.

Changing the baud rate is done in the *Cine-IPM 2K*'s *Communications* submenu. See 3.6, *Adjusting System Parameters and Advanced Controls*.

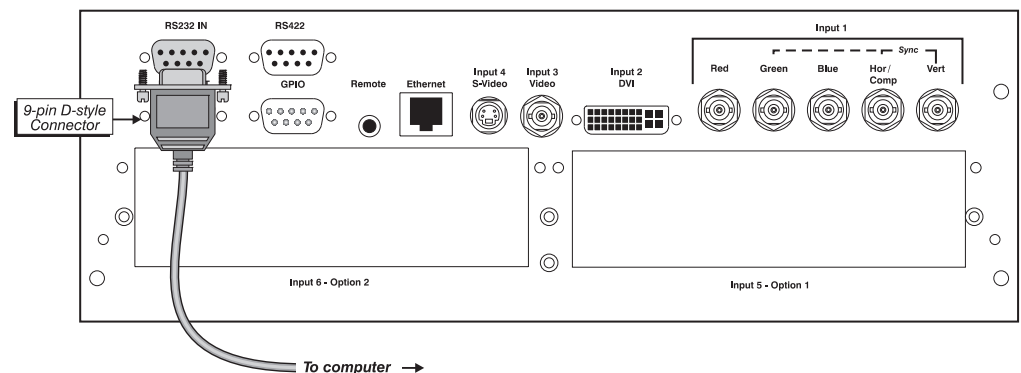

Figure 2.15. Connecting Serial Communications via RS232

RS422 Serial Communications

Some computers can provide RS422 serial communications (often through a plug-in adapter or external converter) rather than the more common RS232 standard. RS422 communication has differential “transmits-and-receives” and is generally better

suited for long distances than is RS232 communication. Note that RS422 is *not* compatible with RS232—connecting a RS232-compatible PC to RS422 can damage the equipment at either end. Consult the documentation provided with your PC if you are unsure.

The 9-pin RS422 connector is located on the front input panel of the *Cine-IPM 2K*. When using this port, make sure to set the baud rate to match that of your RS422 controlling device.

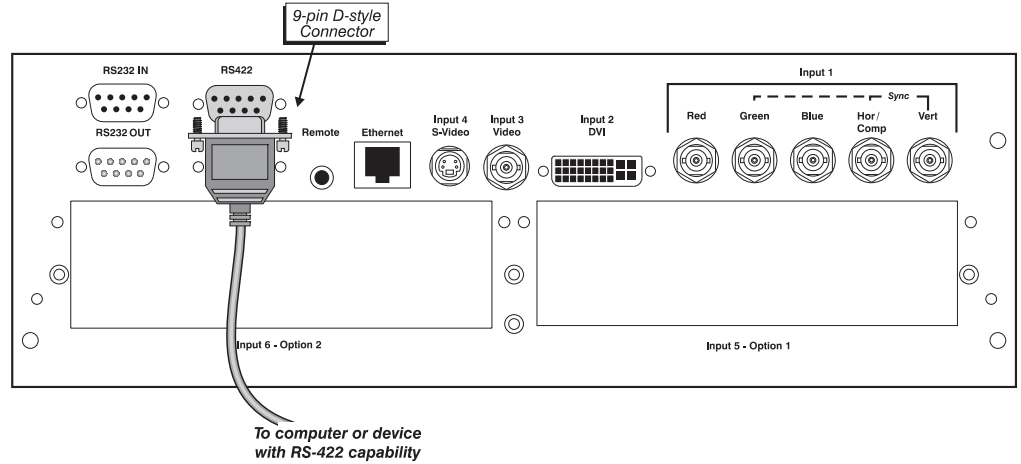

Figure 2.16. Connecting Serial Communications via RS422

⚠ CAUTION ⚠

Do not use an RS422 port unless you are using equipment with RS422 capability. The voltage levels of this signal can damage incompatible equipment.

Ethernet Communications

To add the *Cine-IPM 2K* to an Ethernet network with other equipment such as controllers and other projectors, connect standard CAT5 Ethernet cable between your Ethernet controller (or hub) and the Ethernet port on the *Cine-IPM 2K* front panel.

NOTES: 1) Ethernet crossover cable required if connecting directly to a PC only. 2) Downloading new software to the projector via Ethernet is not supported.

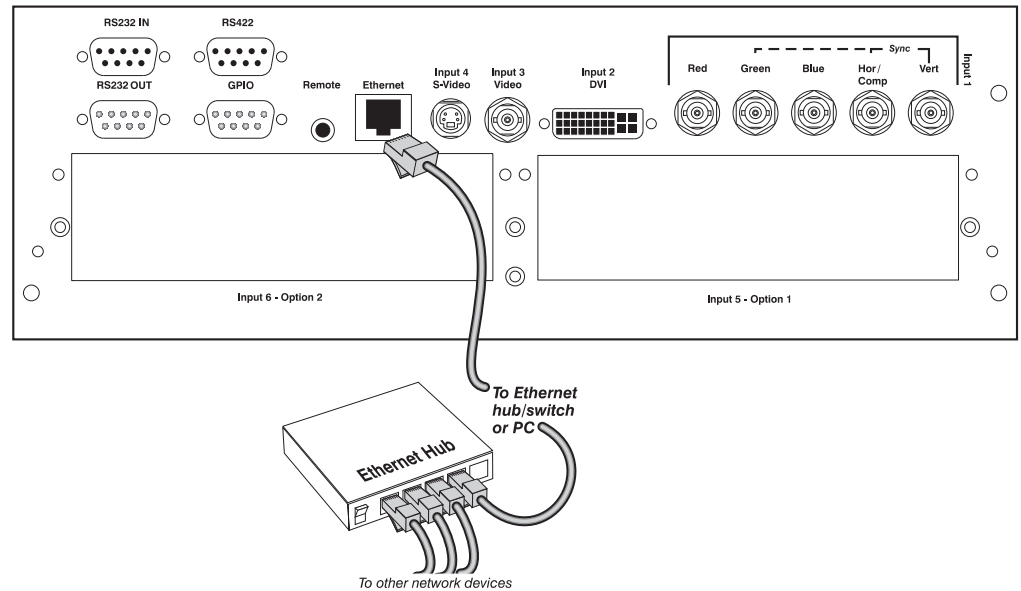

Figure 2.17. Connecting Ethernet

By default upon connection to an Ethernet network, a valid IP address for the *Cine-IPM 2K* will be automatically assigned by a DHCP server. If there is no DHCP server present on your network, or if you want to use a specific static IP address for the *Cine-IPM 2K*, you can set this address in the *Ethernet Settings* menu or via an ASCII serial command.

Regardless of how it is assigned, once a *Cine-IPM 2K* has a valid and unique address it will respond immediately to commands sent to this address. To determine the *Cine-IPM 2K*'s current IP address, consult the *Status* or *Communications* menus.

Refer to 3.6, *Adjusting System Parameters and Advanced Controls* for further information about setting up and using a *Cine-IPM 2K* connected via Ethernet.

The GPIO Port

The General Purpose In-Out (GPIO) port enables integration of the *Cine-IPM 2K* within an established control system so that other devices connected via GPIO can operate in tandem with *Cine-IPM 2K*, or vice versa. ASCII commands sent via standard serial ports can be stored in *Cine-IPM 2K* memory, where they can then trigger a sequence of events in response to incoming or outgoing signals at the GPIO port, depending on your programming of the GPIO pins. For example, you can automatically dim the room lighting when the *Cine-IPM 2K* is turned on, or automatically turn the unit off when the lights are raised.

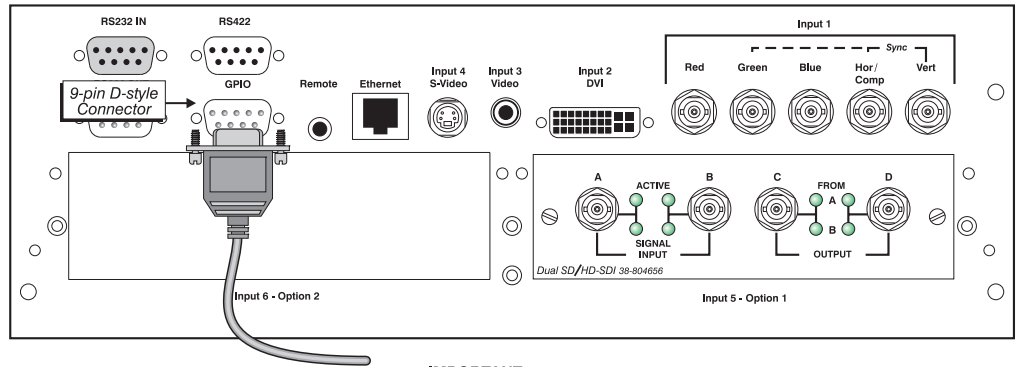

IMPORTANT
Use a serial cable that is compatible with the external device.

Figure 2.18. GPIO Port

For more information, refer to *Appendix D*.

2.5 Setting Up the TPC for Source Selection



At many *CP2000* sites, users may prefer to select their non-cinema *Cine-IPM 2K* sources with a simple button on the TPC *Main* menu. These buttons provide a reliable and quick way to switch to a specific *Cine-IPM 2K* source, but they must first be configured and defined by an installer, administrator, or advanced user having access rights to the TPC *Custom* menu. See below.

NOTES: 1) This procedure assumes familiarity with the TPC. For complete information, see the *CP2000 User's Manual* provided with the projector. 2) The RS232 "B" link is required for source selection at the TPC. 3) Currently the TPC can be configured for switching sources only, not channels.

1. Make sure your *CP2000* and *Cine-IPM 2K* are properly connected via both **DVI** and **RS232 "B"**. Otherwise the two devices cannot communicate with each other.
2. Connect the desired source(s) to the front of the *Cine-IPM 2K*.
3. In the *Cine-IPM 2K* menus, set the desired output resolution and output (8-bit vs. 10-bit; a.k.a. "Data Format"). Remember that 10-bit output requires *both* DVI connections. See right.

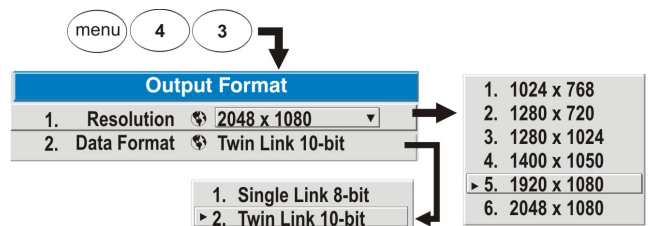

Figure 2.19. Controlling Cine-IPM 2K Output

4. With the projector and *Cine-IPM 2K* both powered up normally, go to the *Custom* menu of the TPC and set the following options (see Figure 2.20):

- Define **INPUT**: Set whether your *Cine-IPM 2K* data link is via **DVI-1** (called "DVI-A" at the TPC) or **DVI-2** (called "DVI-B" at the TPC), or whether the incoming data is shared in a **DVI-TWIN** (10-bit) configuration utilizing both DVI routes. With any of these three TPC input options, you must still use the remote keypad to select the desired *Cine-IPM 2K* input (#1-6). Alternatively, if you have multiple sources connected to the *Cine-IPM 2K* for outputting on the 8-bit **DVI-1** link, you may prefer to define a specific

Cine-IPM 2K input (#1-6) for a specific display button. You can then source-switch at any time by selecting this button on the TPC *Main* menu.

NOTE: Using the TPC to select a specific Cine-IPM 2K input 1-6 requires the DVI-1 link. If DVI-2, you must use the keypad.

- Define **DATA FORMAT**: 8-bit output requires “Unpacked 8-bit” data format. If Input is set to **DVI-TWIN** (10-bit output), data format must be “Packed 10-bit”. *NOTE: “Packed 12-bit” is currently not supported.*
- Define **SOURCE**: Select the output resolution currently set in the *Cine-IPM 2K*—by default, this is 2048 x 1080 but other choices are available in the *Geometry and Color* menu.

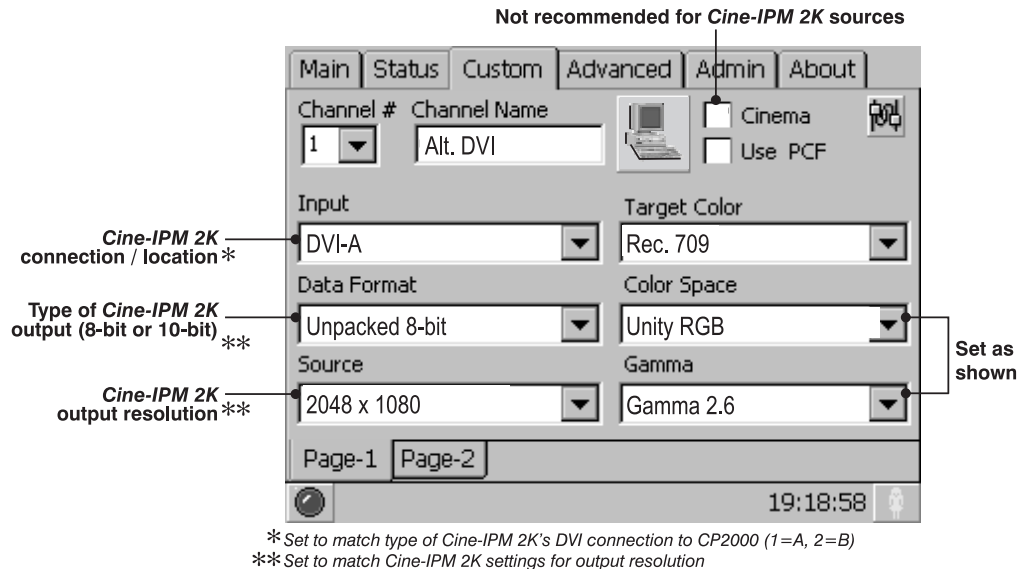

Figure 2.20. Configuring the TPC for Cine-IPM 2K Sources (EXAMPLE)

- Define **SCREEN**: Set to “2048 x 1080 No Crop” to use the full display area of the projector. To use a smaller area, select one of the other screen options.
 - Set **GAMMA** to 2.6.
 - Set **COLOR SPACE** to Unity RGB.
 - Clear the **CINEMA** checkbox. To achieve maximum throughput, non-cinema processing is recommended for all *Cine-IPM 2K* sources. In rare cases with low resolution sources having limited bandwidth, you may find that the cinema path can be used without cropping.
5. Choose a desired key name and icon for the display button appearing on the TPC *Main* menu.
 6. Settings are saved when you leave the *Custom* menu (they are also saved 5 minutes after opening the menu).

The TPC *Main* menu should now include a button for your newly-defined *Cine-IPM 2K* source. Repeat for remaining *Cine-IPM 2K* sources.

2.6 Linking Multiple Cine-IPM 2Ks

You may wish to link two or more *Cine-IPM 2Ks* together so that commands to and from a controller are relayed from one projector to another (each one having its own *Cine-IPM 2K*). Choose a hardware configuration that best suits your desired communication method.

Serial Links ► **RS232 NETWORK:** To control multiple *Cine-IPM 2Ks* with a computer/controller having an RS232 interface, first set all *Cine-IPM 2Ks* to the same baud rate as the controller, then chain the *Cine-IPM 2Ks* together by connecting the **RS232 OUT** connector of the first *Cine-IPM 2K* (already connected to the computer/controller) to the **RS232 IN** connector of the next *Cine-IPM 2K* in the chain. Continue connecting *Cine-IPM 2Ks* in this manner until you’ve reached the last *Cine-IPM 2K* in the chain, so that only the last *Cine-IPM 2K* has an unused **RS232 OUT** port. See Figure 2.21.

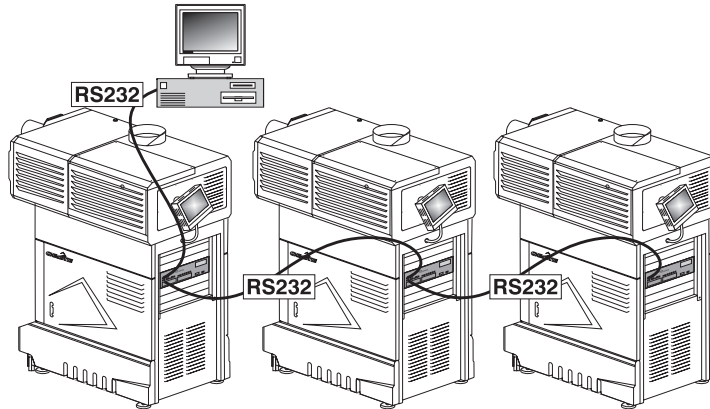

Figure 2.21. Typical RS232 Network

MIXED NETWORKS: To control multiple *Cine-IPM 2Ks* with a computer/controller having an RS422 interface, first set them all to the same baud rate as your RS422 controller.

NOTE: You must enable this combination of RS422 and RS232 in the Communications menu. Set the “Network Routing” option to “RS232 and RS422 Joined”. See Section 3 for details.

Daisy-chain the *Cine-IPM 2Ks* together by connecting an **RS232 OUT** port of the first unit (already connected to the computer/controller through its **RS422** port) to the **RS232 IN** port on the next *Cine-IPM 2Ks* in the chain. Continue connecting *Cine-IPM 2Ks* in this manner until you’ve reached the last unit in the chain, so that only the last *Cine-IPM 2K* has an unused **RS232 OUT** port.

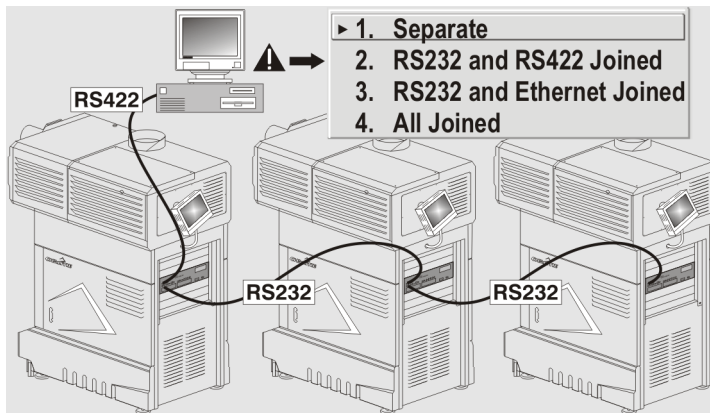

Figure 2.22. Mixed Serial Network

Note that communication parameters such as baud rate must be set to match the particular controlling device *before* connecting as a network—refer to the documentation that came with your controlling device in order to determine the proper baud rate. See 3.6, *Adjusting System Parameters and Advanced Controls* if you

need help changing the projector baud rate. In addition, set the Network Routing to “RS232 and RS422 Joined” if you want to reach all *Cine-IPM 2K / CP2000* sets.

NOTES: 1) To avoid damage, connect only properly wired serial communication cables. See Appendix C for details. 2) It is recommended that each RS232 communication cable be no more than 25 feet in length. Use high quality cables.

Ethernet Networks ► **ETHERNET NETWORK SETUP:** To add one or more *Cine-IPM 2Ks* to an Ethernet network, use standard CAT5 cable to connect each unit’s front Ethernet port to a hub belonging to the network. A controller or PC must also be connected to the hub. See Figure 2.23.

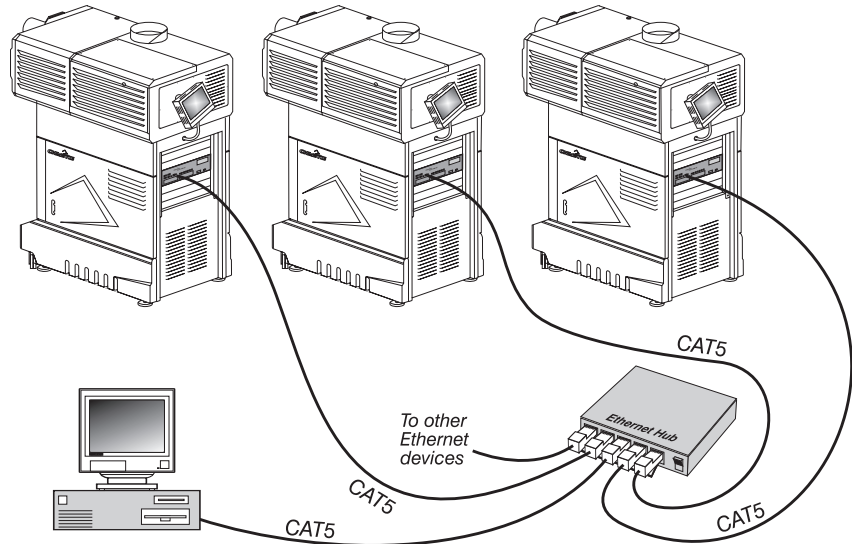

Figure 2.23. Typical Ethernet Network

SETTING THE *Cine-IPM 2K*'s IP ADDRESS: By default, a DHCP server (if present) will automatically assign a valid and unique IP address for each *Cine-IPM 2K* present, upon connection to most Ethernet networks. Depending on the network, this DHCP-assigned IP address usually remains stable for the current session, but may change with subsequent power-ups and logins. On some networks, the address will even remain stable from session to session. In all cases, the *Cine-IPM 2K*'s IP address and port appear in the *Status* menu as well as the *Ethernet Settings* submenu.

Ethernet Settings	
1.	DHCP Enabled <input checked="" type="checkbox"/>
2.	IP Address 000.000.000.000
3.	Port 3002
4.	Subnet Mask 255.255.000.000
5.	Default Gateway 000.000.000.000
6.	Network Name ChristieA12924
7.	ArtNet Interface Settings

← = Projector's IP address will be DHCP-assigned
 = Use static address assigned in "IP Address"

Ethernet settings only take effect after exiting this menu.

Figure 2.24. Setting the *Cine-IPM 2K*'s IP Address

If you have no DHCP server on your network, or if you simply wish to assign a specific static address, enter this address in the *Ethernet Settings* submenu or send it to the *Cine-IPM 2K* via a serial command. The unit will respond immediately and permanently to commands sent to this address until you enter a new address, or until you re-enable the DHCP auto-assign checkbox.

CHANGING THE PORT#: On some Ethernet networks, firewall restrictions may require that the port number of the *Cine-IPM 2K* be changed from its default of 3002. If so, enter a new port number in the *Ethernet Settings* menu or include the new port# in an XIP serial command sent to the *Cine-IPM 2K*. NOTE: It is recommended you do not use port numbers below 1000 as they are typically reserved by common TCP applications.

SUBNET MASK AND DEFAULT GATEWAY: The Subnet Mask and Default Gateway are automatically assigned when DHCP is enabled. If a static IP address is used, assign it first since the subnet mask is estimated after it is entered. The Default Gateway allows you to specify the address of a local router, which enables the transmission of data between separate IP networks.

NETWORK NAME: Set the name for the projector, as it should appear on the local network. The control is most useful when DHCP is enabled, since the IP address may change from one session to another.

ArtNet INTERFACE SETTINGS: Refer to 3.6, *Adjusting System Parameters and Advanced Controls* for additional information about ArtNet settings.

Communicating to Certain Ports

► By default, communications originating from one type of serial controller—RS232 vs. RS422 vs. Ethernet—stay on the corresponding network path. This separation is indicated by a “Separate” setting for “Network Routing” in the *Communications* menu. If you are using an RS422 controller, for example, the device communicates *only* with the *Cine-IPM 2K* to which it is connected unless you change this setting to either “RS232 and RS422 Joined” or “All Joined”(Figure 2.25).

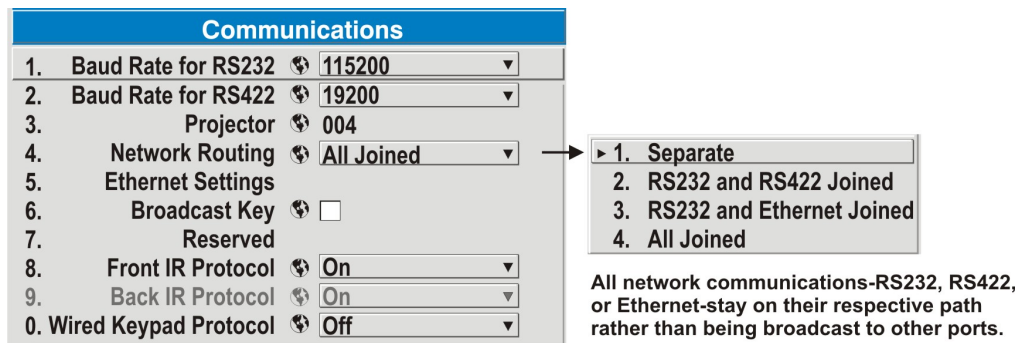
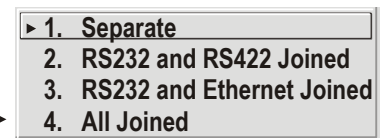

Figure 2.25. Keeping Communications Separate (default)

Communicating to All Ports

► To relay all messages to all ports—RS232, RS422, and Ethernet—set the “Network Routing” option in the *Communications* menu for each projector to “All Joined”. This configuration is useful if you are using a non-RS232 controller with the RS232 linking available between these *Cine-IPM 2Ks*. For example, you may want to use both an RS422-compatible controller and an Ethernet-connected PC for working with a network of *Cine-IPM 2Ks* linked via their RS232 in/out ports (Figure 2.26).



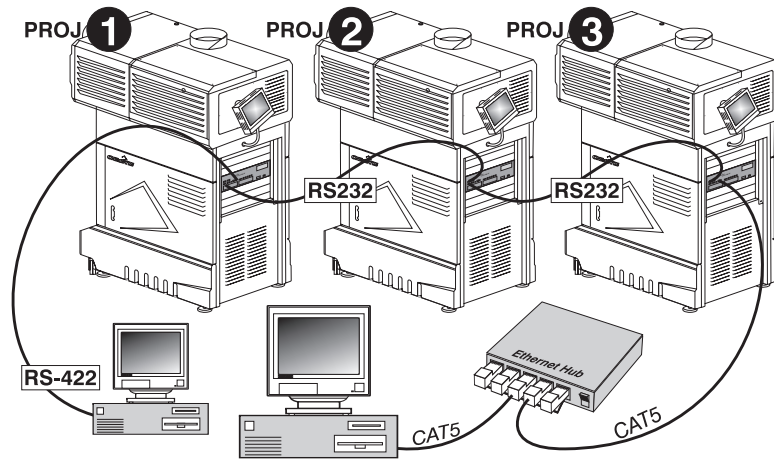

Figure 2.26. Joining All Networks

To isolate *just* RS422 communications, select “RS232 and Ethernet Joined”. In Figure 2.26, only projector #1 will respond to the RS422 controller. To isolate *just* Ethernet communications, select “RS232 and RS422 Joined”—only projector #3 will respond via Ethernet while all will respond to the RS422 controller.

Projector Numbers ► It is helpful to define a unique 3-digit projector number—001, 002, 003, etc.—to each projector connected in a serial (RS232 or RS422) network. These numbers enable you to direct *Cine-IPM 2K* serial commands to a single projector rather than broadcasting to the entire network. For complete information on how to assign and use projector numbers on a serial network, see 3.6, *Adjusting System Parameters and Advanced Controls*.

2.7 Converting the Keypad

If desired, convert an IR remote keypad into a wired remote keypad and vice versa. Select the new desired function in the *Communications* menu and add or remove the cable and batteries as appropriate.

NOTE: In either configuration, batteries are required for powering the laser pointer.

1. Using the keypad as either an IR (infrared) remote or with its cable connected to the *Cine-IPM 2K*, display the *Communications* menu.
2. Set the new desired keypad function—either “Front IR” or “Wired Keypad”—to **On**. The *Cine-IPM 2K* will now recognize both types of communication signals.
3. For wired function, add the keypad cable (provided) and connect to the **REMOTE** port on the *Cine-IPM 2K*. For IR function, remove the cable and make sure the 4 batteries are installed.
4. If desired, return to the *Communications* menu and turn the opposing keypad functionality to **Off**. This is useful when you are using a wired keypad and need to prevent interference from other nearby IR remotes still in use.

Note that each keypad configuration—wired or IR—controls the **Off** state of the *other* type of keypad. This safeguard prevents accidentally disabling the current keypad.

Operation

3.1 Cine-IPM 2K Basics

This section describes how to use the *Cine-IPM 2K* after it is properly installed by a qualified service technician as described in *Section 2, Installation and Setup*.

Components/Features ► *Cine-IPM 2K* components are shown below. Descriptions begin on page 2-2.

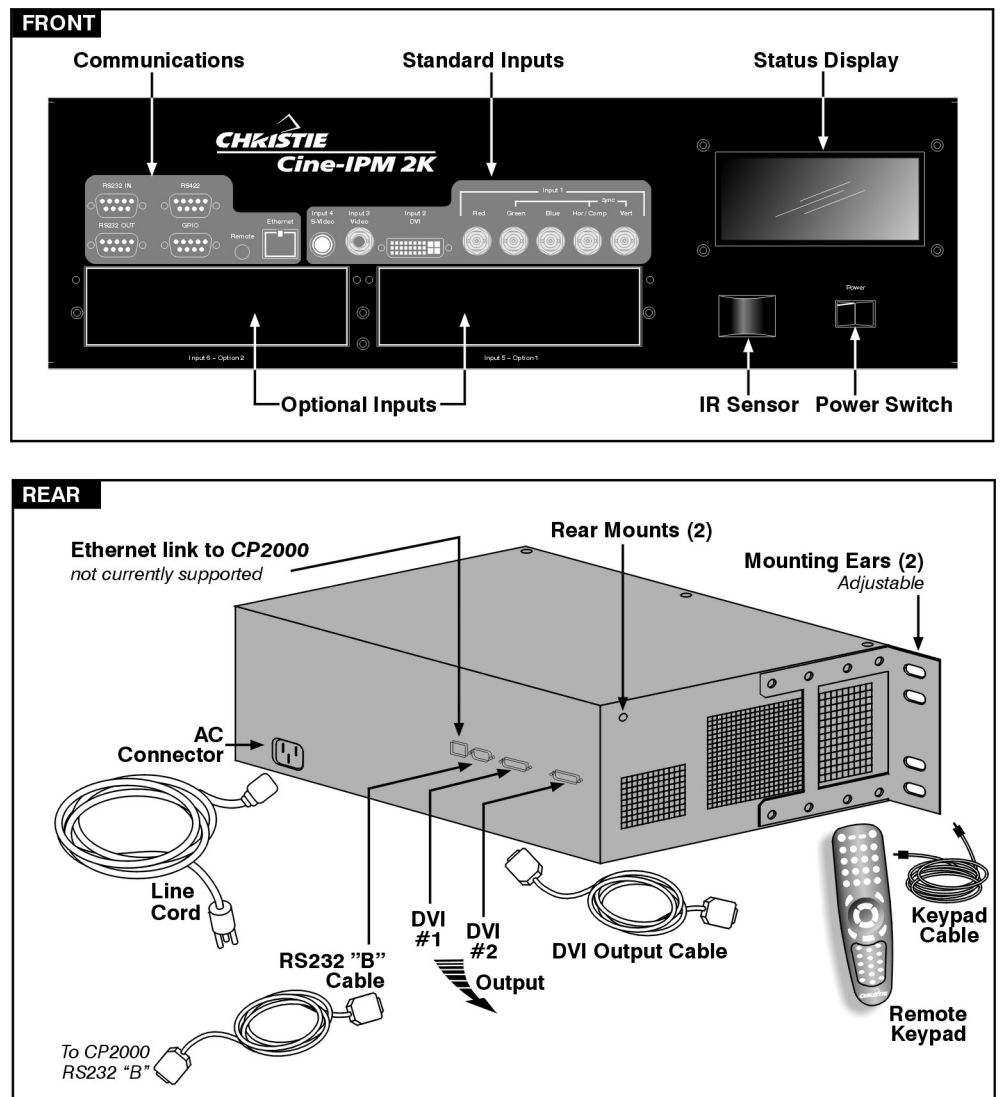

Figure 3.1. Cine-IPM 2K Components

Communications (FRONT)

Connect all external communication links here, such as a wired keypad, Ethernet, and/or a serial link from your PC or another *Cine-IPM 2K*. See *Section 2* for details of connection and setup of all communications.

- ❑ **RS232:** Connect an RS232-compatible PC or other controller for typical serial communication to and from the *Cine-IPM 2K*. These in-out ports also provide loop-through connection to additional *Cine-IPM 2Ks*, creating a serial network, and are used for downloading new software to the *Cine-IPM 2K*.
- ❑ **RS422:** Connect an RS422-compatible controller for unusually long-distance serial communication.
- ❑ **GPIO:** Connect the desired GPIO-compatible device here for integration of the *Cine-IPM 2K* with an established control system. Devices connected via GPIO can operate in tandem with *Cine-IPM 2K*, or vice versa and is often used for automation of regularly scheduled events.
- ❑ **REMOTE KEYPAD:** Connect the wired (tethered) remote keypad if you want to use a keypad for controlling a *Cine-IPM 2K*, such as one that is recessed and hidden inside the *CP2000* pedestal. In such cases, the cable is typically routed out the front toe of the pedestal.
- ❑ **ETHERNET:** Connect to an Ethernet network with other equipment such as controllers and additional projectors.

Standard and Optional Inputs

Connect all desired non-cinema input sources here. See *Section 2* for more information about connecting sources, and refer to *Section 6* for specifications.

Status Display

Full status and error messages appear in this window.

IR Sensor

The IR sensor detects commands from the *Cine-IPM 2K* IR remote keypad. Turn this response on or off in the *Communications* menu.

Main Power Switch

When switched to **On**, the *Cine-IPM 2K* is ready for power-up and the *Status Display* window is functional—it shows “Power Off” until you press  on the keypad. When switched to **Off**, the *Cine-IPM 2K* is disconnected from AC (similar to unplugging the unit) and cannot be detected by the TPC.

AC Connector and Line Cord

Use the *Cine-IPM 2K* line cord for any installation. Plug into an appropriate wall outlet or use the convenience outlet in the *CP2000* pedestal. The *Cine-IPM 2K* is rated for 100-240 VAC—see *Section 6, Specifications* for more information.

Outputs and Communications to CP2000 (REAR)

All links to the *CP2000* and/or other display device are routed from the rear of the *Cine-IPM 2K*.

- ❑ **DVI #1 and DVI #2:** The *Cine-IPM 2K* sends output through identical DVI ports located on its rear panel—connect DVI-1 or both of these outputs to the *CP2000* and/or other display device (two DVI cables provided). See 2.3, *Connecting DVI Outputs* for details.

- ❑ **ETHERNET:** The *Cine-IPM 2K*'s rear Ethernet port is currently non-functional.
- ❑ **RS232 “B”:** If you will want to select your *Cine-IPM 2K* inputs using the *Touch Panel Controller* on the *CP2000*, you must connect the *Cine-IPM 2K*'s RS232 cable between the rear RS232 “B” port on the *Cine-IPM 2K* and the RS232 “B” port on the *CP2000*. This custom Christie-proprietary cable enables communication between the *Cine-IPM 2K* processor and the *CP2000* so that you can 1) use the TPC to switch *Cine-IPM 2K* sources and 2) obtain *Cine-IPM 2K* status updates.



Do not use RS232 “B” ports and cable with other equipment or in other configurations.

Mounting Ears (2)

Mounting ears enable the *Cine-IPM 2K* to be installed in the rear of the *CP2000* pedestal, or rack-mounted in a separate standard 19-inch rack. To recess the *Cine-IPM 2K*, position its ears as far forward as possible before installation—this creates a convenient gap for routing your external connections away from the front panel. Make sure to secure each ear with 4 screws. Or move the ears fully back for a flush-front installation.

Rear Mounts

If the *Cine-IPM 2K* is installed in the *CP2000* pedestal, add support strapping between the pedestal frame and the two rear mounts at the rear corners of the *Cine-IPM 2K*.

3.2 Using the Keypad

All functions in the *Cine-IPM 2K* can be controlled and adjusted using the remote keypad—refer to the key descriptions provided for the IR remote (Figure 3.2). Use either as a wireless IR remote or convert to wired use.

As IR Remote ► The IR remote keypad uses wireless communications from a battery-powered infrared (IR) transmitter to control the *Cine-IPM 2K*. Direct the keypad toward the IR sensor on the *Cine-IPM 2K* front panel.

As Wired Remote ► The IR remote converts into a wired remote with the addition of a cable (supplied) which connects to the front of the *Cine-IPM 2K*. You must also select the “Wired Keypad” option in the *Communications* menu. Use a wired remote when lighting conditions interfere with proper IR transmission, or when the IR sensor is inaccessible, such as when the *Cine-IPM 2K* is secured within a closed *CP2000* pedestal.

NOTE: Keep batteries in the keypad for powering the laser pointer.

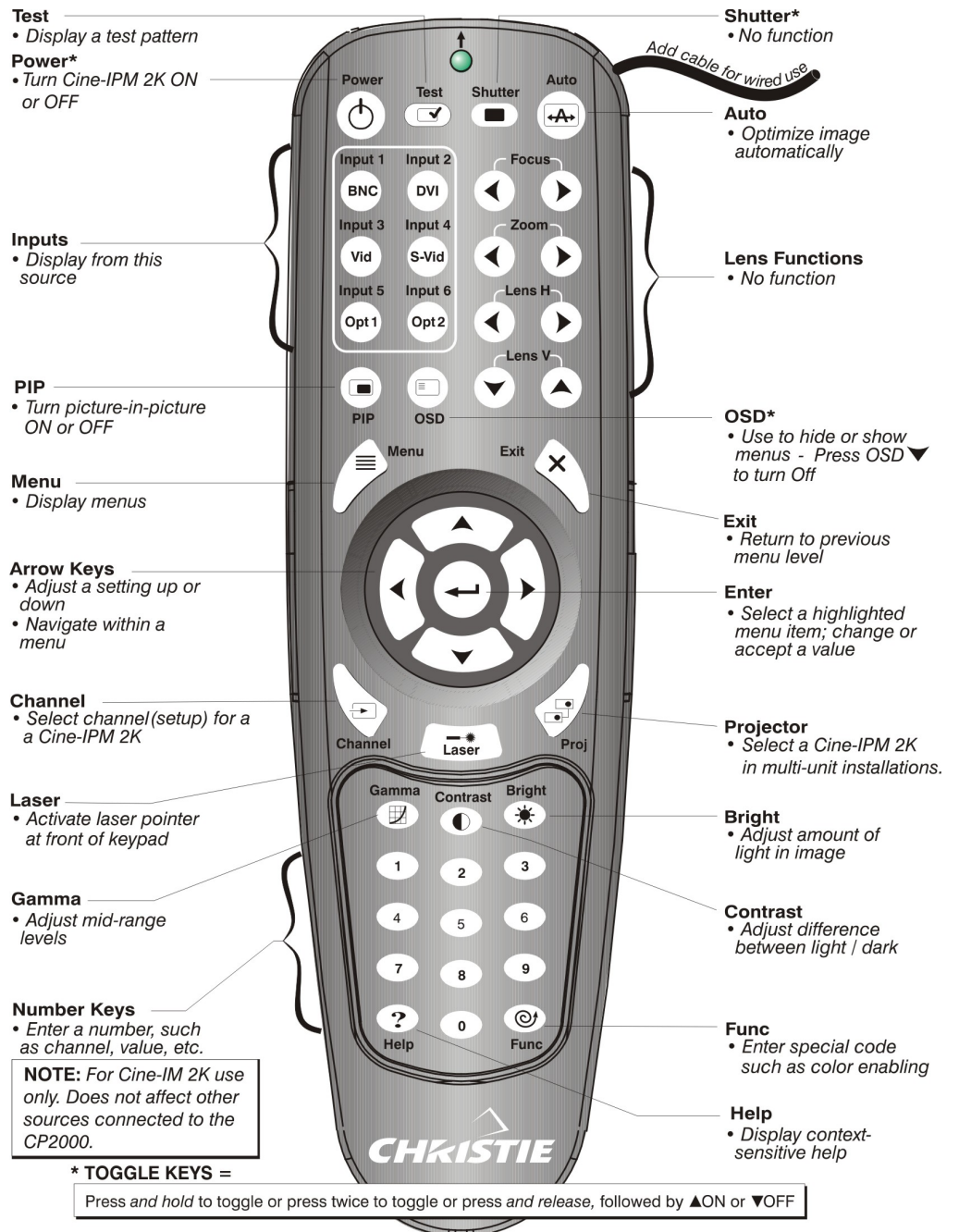







Figure 3.2. Standard Remote Keypad

Guide to Keypads ► Keep in mind the following guidelines:

- 1) Press keys one-at-a-time; there are no simultaneous key combinations required.
- 2) To protect against accidental use, the two “toggle” keys—Power and OSD—are “press-and-hold” keys that do not function with a typical quick press-and-release key press.
- 3) Hold arrow keys down for continuous adjustment/movement in one direction. In serial networks, pause briefly between adjustments to ensure that more distant Cine-IPM 2Ks can “keep up” with the commands.
- 4) If you press a key while the Cine-IPM 2K is still responding to the previous action, such as during power-up, the second key press may not take effect.

Keypad Commands ► Specific keypad commands are explained below:

Power ON/OFF

With the main power switch set to **On**, press *and hold*  for a second or two to toggle the *Cine-IPM 2K* on or off with a single keystroke. Or press and release  followed immediately by  (on) or  (off) to guarantee the correct toggle (useful if you are unsure of the present state). Alternatively, press   to toggle from the present on/off state.

NOTE: During Cine-IPM 2K power-up, the internal fan powers up and the Status Display window displays “Powering Up” along with input frequency data or “No Signal” or error. The TPC will be able to detect the Cine-IPM 2K at this point.

Test

Press  to scroll through the *Cine-IPM 2K*'s internal test patterns in order, including the current input. Or use   to scroll only the test patterns (no input) in either direction.





Auto

Press Auto (a.k.a. “*Auto Setup*”) to initiate an automated process in which the *Cine-IPM 2K* optimizes critical display parameters such as size, position, pixel tracking, etc., for the current source. These parameters are listed in Table 3.1. An *Auto Setup* can save time in perfecting a display, and you can modify the adjustments as desired.

Table 3.1. Auto Setup



What an “Auto Setup” Does	
OPTIMIZES:	SETS TO DEFAULT:
Pixel Tracking	Contrast
Pixel Phase	Brightness
Size and Blanking	Auto Input Level (off)
Vertical Stretch	Detail (if video source)
Position	Filter
Input Levels	Luma Delay

NOTE: You must have an unlocked channel present to use Auto Setup.

 Press  to display summary information about the current menu or highlighted menu option. Or, if there is no menu present, press  to access a list of general help topics. To exit any help text, press  again (or .

Channel

Press to select a specific source setup (*channel*) defined and stored in *Cine-IPM 2K* memory. Once you enter a 2-digit channel number (or, if there is a list displayed, highlight it and press ) , the display will automatically change and update according to the numerous setup parameters defined for that channel. Note that a new channel is automatically created if you adjust an image from a new source.

*NOTE:  key behavior during a presentation depends on whether or not the **Display Channel List** option is enabled in the **Menu Preferences** menu. You can choose to use a scrollable list of channels when you press , or you may prefer to enter the desired channel number “blind”, i.e., without on-screen feedback. See **Menu Preferences** later in this section.*

Input 1

Press **Input 1** to display from the data input source connected to BNCs labeled **INPUT 1**. If PIP is enabled, pressing this key will change the PIP source.

Input 2

Press **Input 2** to display from the DVI source (analog or digital) connected to **INPUT 2**. If PIP is enabled, pressing this key will change the PIP source.

Input 3

Press **Input 3** to display from the composite video source connected to **INPUT 3**. If PIP is enabled, pressing this key will change the PIP source.

Input 4

Press **Input 4** to display from the S-video source connected to **INPUT 4**. If PIP is enabled, pressing this key will change the PIP source.

Input 5

Press **Input 5** to display from the **INPUT 5** interface module installed in the Option 1 slot. If PIP is enabled, pressing this key will change the PIP source. If the *Dual SD/HD-SDI Module* is installed here, with two inputs connected to it, the second input (B) is considered **INPUT 7**. Use **INPUT 5** to access **INPUT 7** as follows:

- While displaying from **INPUT 5**, press **Input 5** again. This switches to **INPUT 7**.
- While displaying from any input *other* than the *Dual SD/HD-SDI Module*, press **Input 5**. This switches to either **INPUT 5** or **INPUT 7**, depending on which of the *Dual SD/HD-SDI Module* inputs (A or B) was last used. Press **Input 5** again to display from the other *Dual SD/HD-SDI Module* input.

Input 6

Press **Input 6** to display from the **INPUT 6** interface module installed in the Option 2 slot. If PIP is enabled, pressing this key will change the PIP source. If the *Dual SD/HD-SDI Module* is installed here, and there are two inputs connected, its second input (B) is considered **INPUT 8**. Use **INPUT 6** to access **INPUT 8** as follows:

- While displaying from **INPUT 6**, press **Input 6** again. This switches to **INPUT 8**.
- While displaying from any input *other* than the *Dual SD/HD-SDI Module*, press **Input 6**. This switches to either **INPUT 6** or **INPUT 8**, depending on which of the *Dual SD/HD-SDI Module* inputs (A or B) was last used. Press **Input 6** again to display from the other *Dual SD/HD-SDI Module* input.

Contrast

Press **Cont** to change the amount of white in your images. Use **Left Arrow** **Right Arrow** keys until you reach the desired level of white—for best results, start low and increase so that whites remain bright but are not distorted or tinted, and that light areas do not become white (i.e., “crushed”). Conversely, low contrast causes dim images. See 3.5 *Adjusting the Image* (*Image Settings* subsection).

Brightness

Press **Bright** to increase or decrease the amount of black in the image. Use **Left Arrow** **Right Arrow** keys until you reach the desired level of black—for best results, start high and

decrease so that dark areas do not become black (i.e., “crushed”). Conversely, overly high brightness changes black to dark gray, causing washed-out images. See 3.5 *Adjusting the Image* (*Image Settings* subsection).

Gamma



“Gamma” is a global setting that determines what gray shades are displayed between minimum output (black) and maximum output (white) for all signals. The proper setting helps maintain optimized blacks and whites while ensuring a smooth transition for the “in-between” values utilized in colors. Thus, unlike brightness and contrast settings controls, the overall tone of your images can be lightened or darkened without changing the two extremes, and all images will be more vibrant yet with good detail in dark areas.





The normal gamma setting of 2.22 is correct for most signals and conditions. If excess ambient light washes out the image and it becomes difficult or impossible to see details in dark areas, lower the gamma setting to compensate. Conversely, if the image shows excessive detail in black areas, increase the gamma setting. Again, good gamma improves contrast while maintaining good details for blacks.

Menu

Press  to enter or exit the *Cine-IPM 2K*'s menu system.

OSD (On-screen display)

Press   to hide the *Cine-IPM 2K*'s menu system during use. To see the menus again, do one of the following:

- Press *and hold*  for a second or two
- Press and release  followed immediately by 
- Press  



Invisible menus are fully functional, enabling “hidden” access to numbered features and image adjustments by entering the corresponding sequence of keypresses on the keypad.

*NOTES: 1) With OSD “on”, you can still hide on-screen error messages and direct slidebars doing so in the **Menu Preferences** menu. 2) The state of the on-screen display is shown in the Status Display Window on the front of the **Cine-IPM 2K**.*

Shutter

No function. The *CP2000* shutter is controlled at the *Touch Panel Controller*.

Function Key

IF WITHIN A MENU: Using the  key for special tasks within the menu system is noted with the appropriate topic elsewhere in *Section 3*. For example, press  in the *Channel Setup* menu to enable deletion or copying of a channel.

IF WITHIN A PRESENTATION: Press **Func** followed by a 2-digit number to enable a specific color or colors in the display (see right). For example, **Func 6 4** will display only red and green data, **Func 6 7** will display all color data. Eliminating one or more colors can help with certain diagnostics and setups, such as when accurately overlaying one image on top of another from stacked projectors.

Func	6	1	= Red
Func	6	2	= Green
Func	6	3	= Blue
Func	6	4	= Red & Green
Func	6	5	= Green & Blue
Func	6	6	= Red & Blue
Func	6	7	= All Colors

NOTE: Color enabling can also be implemented from numerous locations within the menu system.

DEFINING OTHER USES: Through ASCII messaging on a PC, you can also create special user functions for keys 1-5 and 7-9, or others. For example, **Func** can be programmed to trigger RTEs (Real-Time Events) or to display custom menus. Refer to the separate *Christie Serial Communications* publication available at the Christie website.

Proj Projector

Press **Proj** to access a specific *Cine-IPM 2K* within a group, or to confirm if the local *Cine-IPM 2K* is listening. The number in the “Enter Number” window indicates which *Cine-IPM 2K* is currently listening to commands, and will match the “projector” number that has been defined in the *Menu Preferences* menu. In this case, remember that the “projector” number refers to the *Cine-IPM 2K* rather than any projector to which it is connected.

The “Projector” checkbox (read-only) shows whether or not the *Cine-IPM 2K* physically connected to a keypad is listening to commands from that keypad. A checkmark means that connected *Cine-IPM 2K* is listening; if there is no checkmark, you are communicating with a different *Cine-IPM 2K*.

To control a specific *Cine-IPM 2K* with the keypad, enter the 3-digit number assigned to the *Cine-IPM 2K* you want to use. If you switch to a *Cine-IPM 2K* other than the one you are currently using, the checkmark will disappear.

To broadcast to multiple *Cine-IPM 2Ks*, press **Proj** and then **Proj** again *without* entering a projector number. Keypad commands will then affect all *Cine-IPM 2Ks* present. Note that there is no method of controlling a **group** of *Cine-IPM 2Ks* within the same wired configuration using the wired keypad exclusively, since there is only one wired protocol available in this type of keypad.

NOTE: The "Broadcast Keys" option in the Communications menu must be selected for only one (any) Cine-IPM 2K in a serial network. The keypad in use must be OFF (disabled) for the remaining Cine-IPM 2Ks. See also 2.7, Converting the Keypad and 3.6, Adjusting System Parameters and Advanced Controls.

← Enter

Press **←** (or **Enter** on the standard remote keypad) to select a highlighted item, to toggle a checkbox, or to accept a parameter adjustment and return to the previous menu or image.

Exit

Press **Exit** to return to the previous level, such as the previous menu.

NOTE: **Exit** does not save changes within text editing boxes (including number editing of a slider value) or within pull-down lists. It acts as a “cancel”.

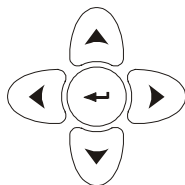

Arrow Keys

Use the **Left** **Right** keys to change a slider value or to select a different option within a pull-down list without having to first scroll through options. These keys also jump to the next page in long menus. See also *Editing Text* later in *Section 3*.

Use the **Up** **Down** keys to navigate within a menu, pull-down list or text box, or to force the corresponding state for power and OSD keys. See details provided on the back of the remote keypad.

PIP **PIP (Picture-in-Picture)**

NOTE: PIP performance may be limited by certain high frame rate sources.

Press **PIP** to enable or disable the Picture-in-Picture function in which you can display two images can be displayed at once — typically a smaller “secondary” image within a large “primary” background. While you are using PIP, source image adjustments such as resizing, brightness, contrast, etc., affect the secondary image only. To adjust the main image instead, press **PIP** before the adjustment (for example, press **Gamma** **PIP** **Left** **Right** to change the gamma level of the main image). To remove the secondary image from the display and return to a single image, press **PIP** while no menus or sliders are present.



Lens Focus, Zoom and Shift

No function.

3.3 Navigating the Menus

Most controls for non-cinema content processed by the *Cine-IPM 2K* are accessed from within the *Cine-IPM 2K*'s menu system. There are several groups of related *functions*, with each group selectable as a menu item in the *Main* menu as shown at right. Press **Menu** at any time to display this *Main* menu.

On the remote keypad, either enter the number corresponding to the function menu you wish to access, such as **2** for the *Image Settings* menu. Or use the **Up** **Down** keys on any keypad to highlight the desired option, then press **Enter**. The corresponding function menu or pull-down list of further options will then appear.

With a function menu displayed, navigate in a similar manner—enter a menu option number for any numbered option, or use the **Up** **Down** keys to highlight the desired option, then press **Enter** (Enter). Extra long menus have a scroll bar on the right—use the arrow keys to access the remainder of the menu. Locked items or items that do not pertain to the current action or condition appear dimmed and cannot be selected.

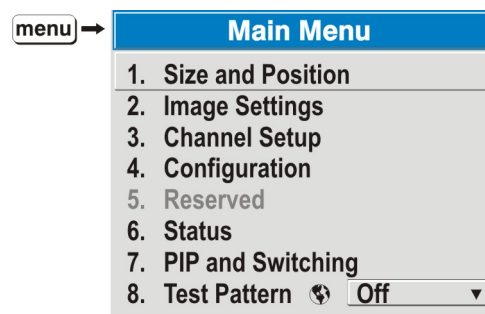

Figure 3.3. Entering the Menu System

NOTES: 1) If there is no signal present, all source-dependent adjustments are disabled. 2) After 15 minutes of inactivity, the Cine-IPM 2K leaves the menu system and returns to the presentation. 3) The **Status** menu is read-only.

When finished with a function menu, do one of the following:

- Press **Exit** to return to the previous screen
- Press **Menu** to leave the menu system and return to the presentation

On-line Help ► If at any time you are uncertain what to do next, press **Help** to display summary information about the current menu or highlighted option. Press **Help** again to exit. In addition, a line of “hint” text is included at the bottom of some menus.

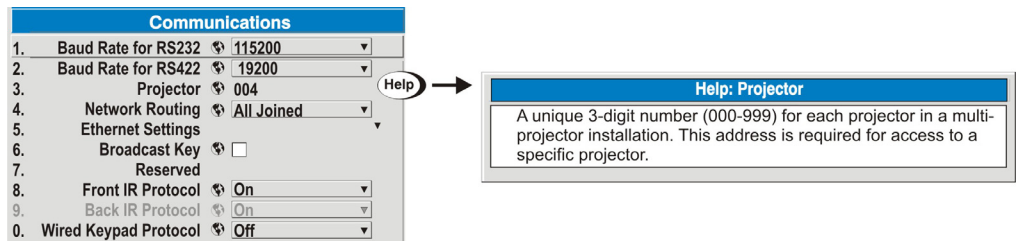

Figure 3.4. Context-sensitive Help

From presentation level, press **Help** to access general *Help Topics*. Scroll as necessary within a topic. Press **Exit** to return to your presentation.

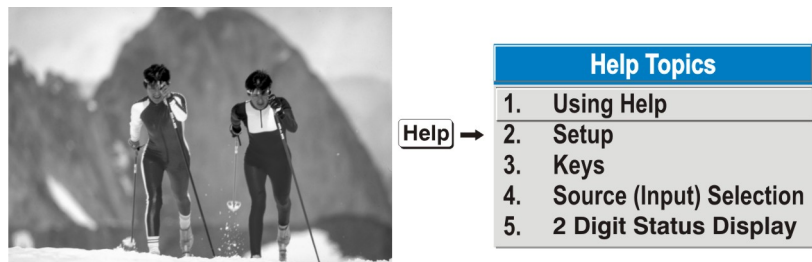



Figure 3.5. Accessing General Help Topics



Time-outs ► If a sidebar, menu, or message is displayed, you have limited time in which to make a keypad entry before the Cine-IPM 2K returns to presentation level **Help** and the graphic disappears. These time-outs may vary depending on what is displayed.

The Global Icon ► Menu options that include this icon  apply universally to any incoming signal.





The PIP Icon ► Menu options showing this icon  apply to PIP (secondary) images only.

Using Slidebars and Other Controls ► Most of the function menus allow you to change settings by using slidebars, checkboxes, and pull-down lists. To select a sidebar, toggle a checkbox status, or view a pull-down list, do one of the following within the function menu:

- Enter the menu option number corresponding to the setting you wish to change (for example, press **1** **3** to select Vertical Stretch in the *Size & Position* menu).
- Or move the highlight to the option desired and press **Enter**.







- Or move the highlight to the option desired and press   to adjust immediately.
- Or bypass the menus entirely and use a single key to immediately access an adjustment during your presentation (*NOTE: applies only to options having their own key, such as Contrast, Brightness, Gamma, etc.*).
- For “blind” access, hide the entire menu system (see OSD key, above) and/or direct slidebars activated by their own key (such as Contrast, Brightness, etc.). Control by using the proper keypress or numerical sequence of key presses.

Once selected, change the setting as desired (see below). Changes take effect immediately and are saved upon exit from all menus, or after 15 minutes.



Slidebars in menus – The current value for a given parameter, such as size or vertical stretch, appears to the left of its slider icon (adjustment window). This number often expresses a percentage, or it may have units associated with it (such as pixels, degrees Kelvin, etc.), depending on the specific option. Press   to gradually adjust the setting up or down—both the number and the length of the bar change accordingly. Hold for continuous adjustment. Or press  to activate a slider text box for specific number entry via the keypad, then press  to save (or press  to cancel).

Filter 5

“Direct” slidebars - For quick access, you access Gamma, Brightness, and Contrast slidebars without traveling the menu system. For example, simply press  to immediately display the same contrast slider accessed with the **Contrast** option in the *Image Settings* menu.

Use the arrow keys to adjust a direct slider, or press  and enter a specific number from the keypad, then  or  or  to save (or  to cancel). When you are done, press  to save and return to your presentation.





*NOTES: 1) You can still adjust a direct slider as usual if the display is turned off (see  or **Menu Preferences** menu) — the slider just won't be visible. 2) A direct slider disappears if it is not used within 5 seconds.*

Checkboxes - Conditions are present if its adjacent checkbox contains a checkmark. To toggle the checkbox, simply highlight and press , or highlight and use  to check and  to uncheck. If a checkbox is numbered, simply enter its number to immediately toggle the checkbox.

5. Broadcast Keys

Pull-down lists – To see a pull-down list of options available for a given parameter labeled with a , you can:

- Highlight it and press  (Enter)
- Or enter the menu option number.

Use  or  keys to navigate up and down within the list (the current choice is noted with a small ). Press  to choose an option from the list, if desired.

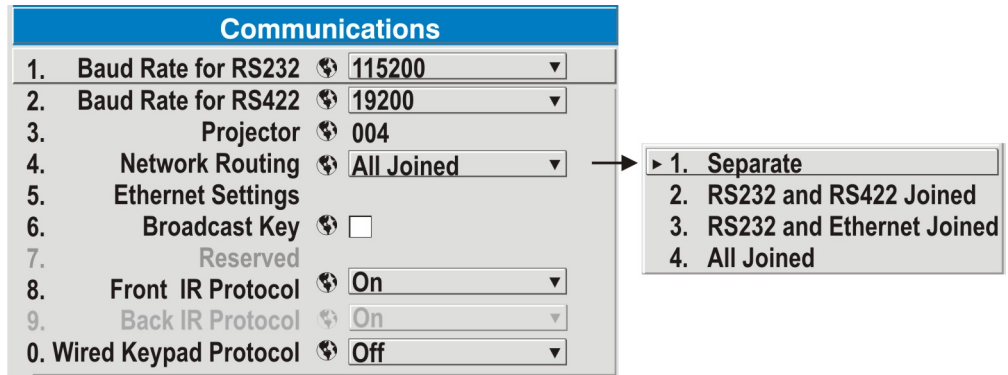

Figure 3.6. Example of Pull-Down List

Or, if you prefer to quickly scroll through a list without first pulling it down, highlight the option and use \leftarrow . Press \leftarrow when the desired choice appears.

NOTES: 1) Press \leftarrow or \rightarrow to jump between pages in an extra long pull-down list. 2) Press Exit while in a pull-down list to **cancel** any change.

Editing Text ▶ **ACTIVATE THE EDIT WINDOW:** To enter or edit text, highlight the desired parameter (such as a channel name) and press \leftarrow to activate its adjacent edit window. Any previously entered text is displayed with its first character highlighted in a square cursor, signifying that this character is ready for editing.

NAVIGATE WITHIN THE EDIT WINDOW: Press \rightarrow to move the cursor forward or \leftarrow to move the cursor backwards as desired.

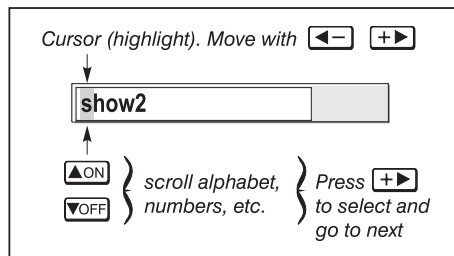
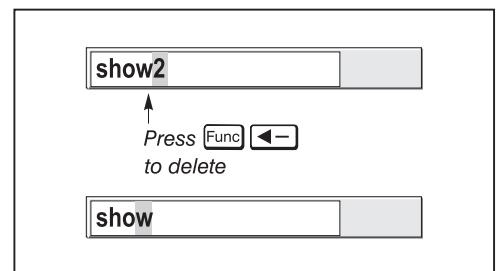
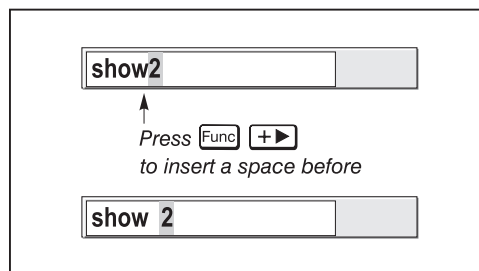

Figure 3.7. Entering Text

EDIT A CHARACTER: To edit a highlighted character, use \uparrow and \downarrow to scroll through the alphabet, numbers, spaces and punctuation available. When the character you need appears, press \rightarrow to select it—the cursor will move to the next character of current text, if present. Note that you can also enter a number directly from the keypad—it will be accepted and the cursor will move on.

ADD OR DELETE A CHARACTER OR SPACE: To insert a space at the cursor location, press Func \rightarrow . To delete a highlighted character (or space), press Func \leftarrow .



PRESS \leftarrow (ENTER) WHEN FINISHED: To accept edits and leave the edit window, press \leftarrow (Enter).

NOTE: Press Exit at any time to cancel changes and return to the previously-defined text.







Editing Numerical Values ► Enter numbers directly from the keypad in order to specify numbers representing *Cine-IPM 2Ks*, channels (source setups), etc. As each digit is entered, it is displayed and the cursor moves on. Note that channel numbers are defined with 2 digits—for example, if you enter only a single digit (such as “7”) for a channel number, the channel will automatically be defined as “07”. Enter “07” to utilize this channel.







NOTES: 1) Once you enter the first digit, this digit replaces all old digits. 2) If you press any non-numbered key, the number entered up to that point is accepted and updated as the new value. 3) Press  to cancel editing of numerical values.

3.4 Using Inputs and Channels

NOTE: See **Section 2, Installation and Setup**, for a full explanation of how to connect sources to the *Cine-IPM 2K*.

The *Cine-IPM 2K* stores and automatically recalls up to 50 different channels (source setups) for a variety of inputs. This memory feature allows you to define and conveniently use a wide variety of customized setups rather than having to repeatedly re-configure the *Cine-IPM 2K* for different presentations. Depending on what you have defined, each physical source connection (i.e., input at the *Cine-IPM 2K*) can have several different channels associated with it.

Do I Select an Input Or a Channel? ► **INPUT** – An input is a source physically connected at the *Cine-IPM 2K*. Pressing , , , ,  or  describes the source signal according to which *input slot* it is connected.

HOW TO SWITCH TO AN INPUT IN EITHER ONE OF TWO WAYS – Pressing the appropriate direct key — , , , ,  or  — is a quick and seamless way to display from one of the six inputs connected at the front of the *Cine-IPM 2K*. Alternatively, if the *CP2000's Touch Panel Controller* (TPC) has been configured for use with the *Cine-IPM 2K*, you can press the appropriate display button on the *Main* menu of the TPC. With either method, the image will be displayed according to the following:

If it is the first time you have used the source/input (or if you used the input but did not define a channel by adjusting anything), the *Cine-IPM 2K* will recognize the new input signal based on its frequencies and polarities, and the projector will automatically display an image according to default settings for such a signal. By default, signals will be output from the *Cine-IPM 2K* in 2048 x 1080 format.

If you used the source once before and changed a display parameter such as contrast, V-Position, etc., then a channel was automatically created and still exists in *Cine-IPM 2K* memory (see below). Using an  key will automatically recall this channel—and all its setup parameters—and update the display accordingly.

If more than one channel exists for the input, the image will be displayed according to the setup parameters for the first channel with matching characteristics.

If PIP is enabled, an input key changes the PIP (secondary) image source only. To switch the main input, use the keypad number keys with “Numbers Select Main Image” activated.

*NOTE: Inputs 7 and 8 require the **Dual SD/HD-SDI** module in either of the Cine-IPM's option slots. For their selection, see also 3.2, **Using the Keypad**.*

CHANNEL - A channel is a collection of measurements, locations and settings that tailor the display of an incoming signal to your specific needs. Since source types and applications can vary greatly, you will likely want to adjust and define a wide variety of parameters, such as brightness, contrast, size, etc., in order to customize and optimize the display from a particular source. For example, the display settings you choose for a VCR source may be very different from those you choose for a high resolution computer source, or one signal may simply vary from another signal used previously through the same input location. Once you have adjusted a display parameter, such as pixel tracking or contrast, all current settings are collectively stored in the *Cine-IPM 2K*'s memory as a unique 2-digit channel, such as **09**. You can have numerous distinct channels available for the same input, any of which can be selected by using the **Chan** key on the keypad followed by the 2-digit channel number.

Shown at right is a sample channel list as would be available from **Chan**. This is typically called the *channel list*.

*NOTE: The **Chan** key may display a channel list or not, depending on what you have defined for "Display Channel List" (see **Menu Preferences** later in this section).*

In order to access channels by using **Chan** on the keypad, you must first create the channels. See below.

current channel#

chan Channel: 02				
01	0,2	pDig	64.09k+	60.12+
02	0,1	i3LG	33.72-	59.94-
03	0,4	iSVid	15.73k-	59.94-
04	0,3	pCVid	15.73+	59.94+
05	0,1	p4WH	Fred's computer	

↑ channel#
↑ input
↑ signal type
↑ H and V frequencies, or channel name

Channel List

Creating a New Channel ►
- AUTOMATIC -

To use a new source with the *Cine-IPM 2K*, a new channel must be added to its memory so that the *Cine-IPM 2K* will respond properly to an input signal from that source in the future. A new channel can be created automatically, as described here, or it can be copied from an existing channel and then edited as desired (see *Copying or Deleting Channels* later in this section).

When you select a direct input (**Input 1**, **Input 2**, **Input 3**, **Input 4**, **Input 5** or **Input 6**), any existing channels in the *Cine-IPM 2K* are searched for matching input and signal parameters. If no match to the incoming input signal is found in currently-defined channels, a new channel is temporarily created based on factory-defined defaults for this type of signal. The *channel number* assigned is the lowest available number from 01-99.

NOTES: 1) An automatic channel will be discarded unless one or more of its parameters are changed, and will not appear in the channel list (see below). 2) If two channels have the same distinguishing source characteristics except for the reversal of sync connectors (i.e., H-sync and V-sync, are switched), they are still defined as distinct channels. 3) You cannot define a new channel without an incoming signal.

If the incoming signal *does* match an existing channel, the image will be set up and displayed as usual according to the parameters currently defined for that channel.

USING A CHANNEL: You can normally select a channel at any time by pressing **Chan** (see right). If you want to prevent a channel from appearing in this list, you must edit the channel as described in *Channel Edit* later in this section. Such a channel can still be selected by entering its number as shown at right.

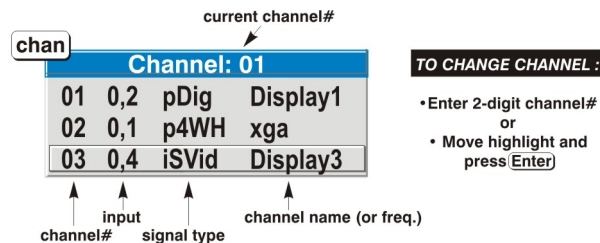

NOTES: 1) The current channel is highlighted upon entering the channel list, or, if this channel is not displayed here, the first channel in the list is highlighted. 2) Channels created automatically do not appear in the channel list unless a parameter for the channel has been changed.

What Channels Are Defined So Far?

All available channels are listed in the *Channel Setup* menu, which describes how each channel can be accessed and which serves as the gateway for editing, copying and deleting channels.

From the presentation level, press **[Menu]** to display the *Main* menu. To display the *Channel Setup* menu, press **[3]**, or move the highlight to the *Channel Setup* option and press **[Enter]**. The *Channel Setup* menu will appear (see sample at right), with the active channel highlighted.

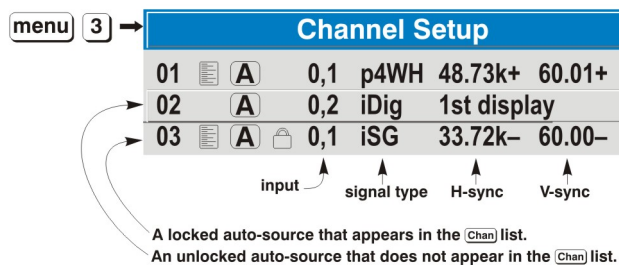
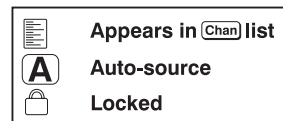

Figure 3.8. All Channels Appear in the Channel Setup Menu

WHAT APPEARS IN CHANNEL SETUP MENU? This menu lists all channels defined so far and indicates where (01-08) they connect to the *Cine-IPM 2K*. The far left column lists channel numbers currently defined. The values in the far right columns indicate horizontal and vertical frequencies—if someone has defined a name for this channel, it appears here instead. Remaining columns contain details pertaining to each channel setup, such as its switcher number (always 0 = *Cine-IPM 2K*), slot location (01-08), a variety of icons indicating access to each channel, and an abbreviated description of each signal type. See *Editing a Channel Setup* for details.



NOTE: If you have more than a handful of channels, use **[←]** and **[→]** to see the remaining channels not visible in the initial display of channels.

SIGNAL TYPE — Either channel list, whether the **[Chan]** key list or the *Channel Setup* menu, identifies signal types in a shortened form as defined below. These descriptors indicate what signal information the *Cine-IPM 2K* uses to identify a match for a given channel, and are preceded by either an “i” (interlaced signals) or “p” (progressive signal“). See Table 3.2.

Table 3.2. Abbreviations for Signal Type

Abbrev.	Signal Type
4WH	Composite (4 wire) on HC input
4WV	Composite (4 wire) on V input
SG	Sync-on-green
5W	Separate H,V
5WR	Separate H,V swapped
SVid	S-Vid
CVid	Composite Video
Dig	Digital

FUNCTIONS WITHIN THE CHANNEL SETUP MENU —To copy, delete or edit a channel, highlight the desired channel in the *Channel Setup* menu and do one of two things:

- Press **Func** if you want to copy the selected channel or delete this or other channels. See *Copying or Deleting a Channel* below.
- Press **Enter** if you want to edit channel setups (i.e., non-image related parameters) for the selected channel. See *Editing a Channel Setup*, below.

Copying or Deleting Channels

TO COPY A CHANNEL, highlight the desired channel in the *Channel Setup* menu, then press **Func** to go to the *Channel Copy/Delete* submenu. Select “Copy” and press **Enter**—a new channel will be created. It is identical to original, which still remains, but it is identified with the next available number from 01-99. If you change your mind and do *not* want to copy the current channel, press **Exit** to cancel and return to the previous menu. Copying channels is a quick method for creating numerous channels, each of which can then be edited and adjusted for a variety of presentations in the future.

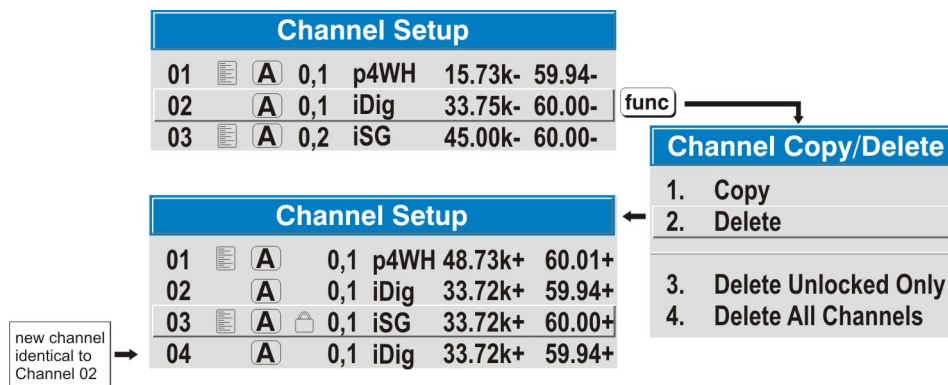

Figure 3.9. Copying A Channel

TO DELETE A CHANNEL, highlight the desired channel in the *Channel Setup* menu, then press **Func** to activate the *Channel Copy/Delete* submenu. Select “Delete” and press **Enter**—a confirmation window will appear to make sure that you really want to delete this channel.

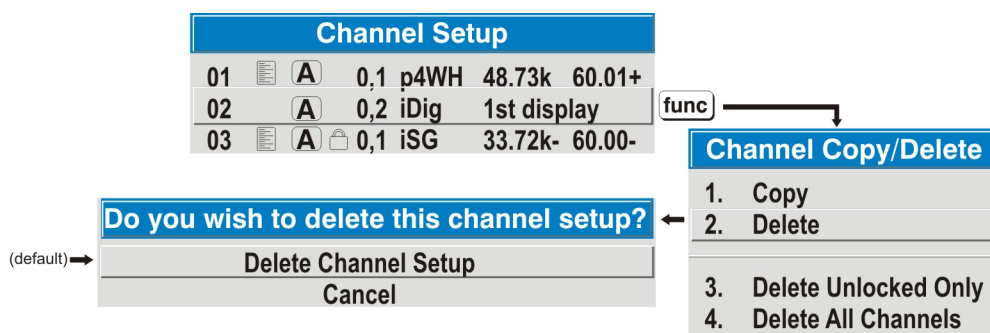

Figure 3.10. Deleting a Channel

TO DELETE MULTIPLE CHANNELS, highlight any channel in the *Channel Setup* menu and press **Func** to go to the *Channel Copy/Delete* submenu. Select “Delete Unlocked Only” and press **Enter** to delete all unlocked channels. Or select “Delete All Channels” to delete all channels, even those that are locked. In either case, the current channel will remain but will be redefined from *Cine-IPM 2K* defaults.

NOTE: For any deletion, a confirmation box appears to make sure that you really want to delete. Select “Cancel” (default) if you don’t want to delete after all.

Editing a Channel Setup ► The basic setups that describe how and where a channel can be accessed are listed in the *Channel Setup* menu. These channel setups can be edited at any time in the *Channel Edit* submenu.

CHANNEL EDIT — STEP 1 From the presentation level press **Menu** to display the main menu. To display the *Channel Setup* menu, press **3**, or move the highlight to the *Channel Setup* option and press **Enter**. The *Channel Setup* menu will appear.

CHANNEL EDIT — STEP 2 To edit parameters shown in the *Channel Setup* menu, select the relevant channel and press **Enter**. The *Channel Edit* menu will appear similar to the sample shown in Figure 3.11.

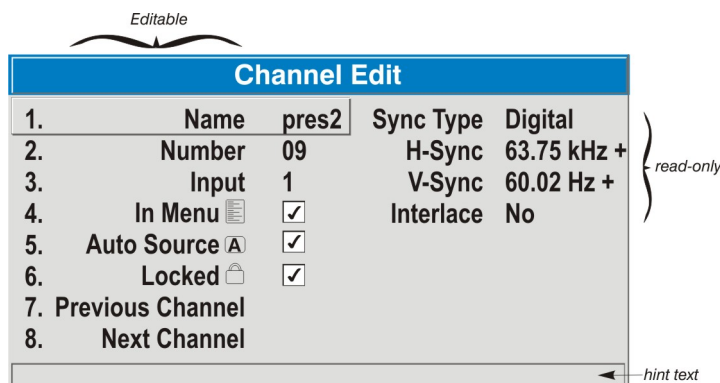

Figure 3.11. Channel Edit Menu (SAMPLE)

CHANNEL EDIT — STEP 3 If desired, review and/or edit the following channel setups in the *Channel Edit* menu:

- **CHANNEL NAME:** An alpha-numeric label can be defined and/or changed here. Channel names can be up to 12 characters in length.
- **CHANNEL NUMBER:** A 2-digit channel number can be changed here.

NOTES: 1) If you enter a channel number that already exists, a dialog

message appears indicating that this number is already in use—assign a different channel number. 2) You can define up to 50 channels.

- **INPUT:** 1-8, corresponding to where on the *Cine-IPM 2K*’s input panel the source is connected.
- **IN MENU:** If checked (default, except for automatically defined channels with unchanged parameters), this defined channel will then appear in the list available when **Chan** key is pressed. If unchecked, the channel must be accessed via **Chan** on the keypad or via the Auto Source function.
*NOTE: On-screen display of the channel list is an option that must be set in the **Menu Preferences** menu.*
- **AUTO SOURCE:** If checked, (default), the *Cine-IPM 2K* can automatically locate this channel when an incoming input signal matches. If not checked, the projector can locate the selected channel only when it is directly selected via **Chan** on the keypad—and a change in input signal will *not* result in a channel change.
- **LOCKED:** If checked, all of the image settings for this channel are disabled. If unchecked (default), all available image settings can be adjusted as desired. You cannot use Auto Setup with a locked channel.
- **PREVIOUS CHANNEL:** Select this option to see or change *Channel Edit* settings for the previous channel in the *Channel Setup* list.
- **NEXT CHANNEL:** Select this option to see or change *Channel Edit* settings for the next channel in the *Channel Setup* list.

3.5 Adjusting the Image

The most commonly used options for non-cinema image adjustments are accessed through two *Cine-IPM 2K* menus: *Size and Position* (**Menu** 1) and *Image Settings* (**Menu** 2), both of which appear in the *Main* menu. From either of these two menus, you can change settings affecting the image from the current channel by working with the appropriate slidebars, checkboxes and pull-down lists. **Exit** will return to the previous menu (or to the presentation, if from the *Main* menu) and accept any changes you may have entered. Settings are saved with the current channel.

From your presentation, you can access any of the individual options in these menus by pressing **Menu** followed by the appropriate two-digit number representing their location in the menu system. For example, press **Menu** 2 3 to quickly access the “Gamma” option in the *Image Settings* menu.

Note that for certain options, you may prefer to use a “direct key” from presentation level to go directly to a particular option without traveling through the menu system (*note: available for certain display parameters only*). For example, press **Contrast** to access the “contrast” sidebar immediately. Press **Exit** to return to your presentation.

*NOTES: 1) To hide these “direct” slidebars, disable the “Display Slidebars” checkbox in the **Menu Preferences** menu. 2) To hide the entire menu system from view, toggle the on-screen display by pressing the **OSD** key.*

Before You Begin ► Use Auto Setup (**Auto Setup**)

For a good and efficient first step in perfecting your non-cinema images, press **Auto Setup**. This initiates an automated process in which the *Cine-IPM 2K* quickly optimizes critical display parameters such as size, position, pixel tracking, etc., based on the type of incoming source data detected. An *Auto Setup* can save considerable setup

time, and you can still modify the adjustments as desired using menu options described below.

Size and Position Menu ► In the *Size and Position* menu, you can increase or decrease the size of your non-cinema image, change its proportion (aspect ratio), move the image to a specific area of the screen, and refine other related parameters. Use *Size and Position* controls to match the image precisely to the screen used at the site.

Size and Position		
1.	Resize Presets	No Resizing ▼
2.	Size	0.729 <input type="text"/>
3.	Vertical Stretch	1.000 <input type="text"/>
4.	Pixel Track	858 <input type="text"/>
5.	Pixel Phase	0 <input type="text"/>
6.	H-Position	360 <input type="text"/>
7.	V-Position	262 <input type="text"/>
8.	Reserved	
9.	Reserved	
0.	Advanced Size and Position	

Refer to "*Using Slidebars and Other Controls*" (earlier in this section) if you need help using any of the options and controls. Changes made in the *Size and Position* menu are applied immediately and are saved when you exit the menu (press **Exit** or **Menu**).

Resize Presets

Select a *Resize Presets* option to output *Cine-IPM 2K* data in its native resolution or so that it closely fills the projector's native resolution of 2048 x 1080, or to optimize the width or height of your display. *Size*, *Position* and *Blanking* parameters will automatically adjust accordingly. Or, if *Blanking* is set first, which defines an Active Input Area, *Resize Preset* scaling will occur in this region of interest only. Resizing options are explained in detail below.

Resize Presets	
1. Default	= maximize for current source
2. No Resizing	= display in native resolution
3. Full Size	= fill the screen (regardless of source)
4. Full Width	= fill display width & keep aspect ratio
5. Full Height	= fill display height & keep aspect ratio
6. Anamorphic	= retain 16:9 aspect ratio
Custom (not selectable)	= non-preset values for <i>Size</i> , <i>Vertical Stretch</i> , <i>H-Position</i> , <i>V-Position</i> and/or <i>Blanking</i>

WHAT IS THE RESIZING DEFAULT? By default when displaying a new *Cine-IPM 2K* source, the output will automatically resize to fill the 2048 x 1080 resolution of the *CP2000*. For sources having a more "square" aspect ratio than that of the *CP2000*, this means the image will appear horizontally stretched until you select a different *Resizing Presets* option or output resolution. See *Select "Default"* below.

WHEN "CUSTOM" APPEARS: The "Custom" re-size descriptor automatically appears in the *Size and Position* menu when any of the values for *Size*, *Vertical Stretch*, *H-Position*, *V-Position* or *Blanking* do not correspond to those for a preset. This option is not offered in the *Resize Presets* pull-down list.

- Select **"DEFAULT"** for most sources (factory default). The image will be centered and displayed as large as possible *depending on the type of source*, as described below:
 - ✓ **A graphic image** will enlarge to fill the screen height, and be centered between black side bars.

- ✓ **A video image** will enlarge to fill the screen height, and be centered between black side bars.
- ✓ **An anamorphic (16:9) image** will fill the height and slightly stretch horizontally to fill the small amount of display area remaining on both sides.

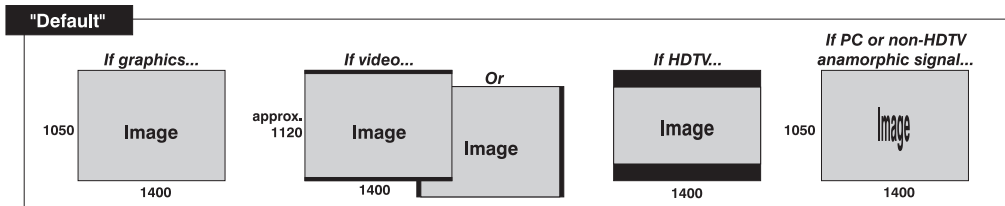

- Select **"NO RESIZING"** to display the image in its native resolution, which may be smaller than the CP2000's 2048 x 1080 resolution. For example, for a source with a native resolution of 800 x 600, "No Resizing" will center a small image within a black border—the black border areas are unused pixels. See below.

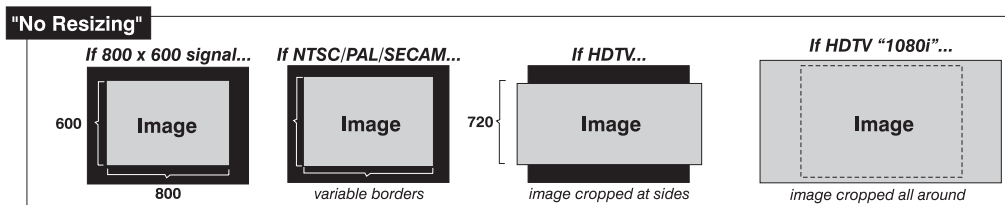

- Select **"FULL SCREEN"** to use *all pixels* (2048 x 1080) for displaying the image, regardless of source or original aspect ratio. See right.

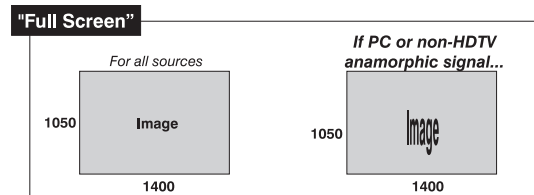

- Select **"FULL WIDTH"** to fill the projector's display from left-to-right without changing the original aspect ratio of the image. Depending on the original source format, data at the top and bottom may be discarded (cropped), or the display may have black borders at the top and bottom. See below.

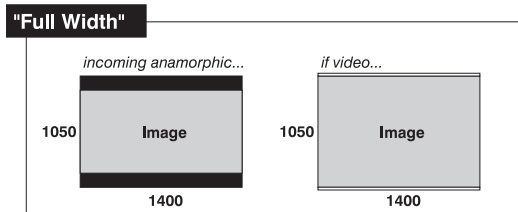

- Select **"FULL HEIGHT"** to fill the display from top-to-bottom. Depending on the source, this may create borders.

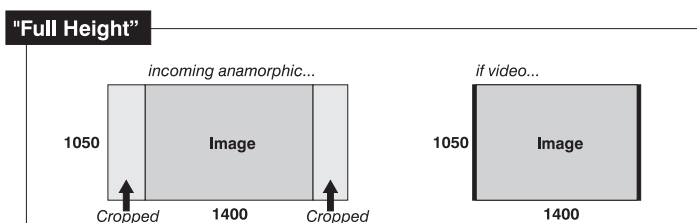

- Select “**ANAMORPHIC**” to display an anamorphic image in its native 16:9 aspect ratio. The image will fill the screen from top-to-bottom, and be centered between narrow black bars on each side.

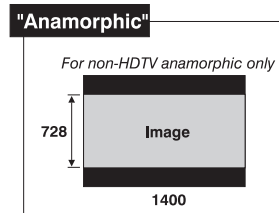

Size

Size controls both the image *width* and *height* in tandem, maintaining the current aspect ratio (proportion) of the displayed signal data.

Vertical Stretch

Vertical stretch adjusts the *height* of the image while keeping the width constant. Use *Vertical Stretch* to change the aspect ratio of the display.

Pixel Track

Steady flickering or several soft vertical stripes or bands across the entire image indicates poor pixel tracking. Proper pixel tracking helps ensure that the image quality is consistent across the screen, that aspect ratio is maintained, and that pixel phase can be optimized (described below). Tracking determines the frequency of the pixel sampling clock, indicated by the number of incoming pixels per line, so that all pixels generated by a particular source are sampled.

NOTE: By default, the Cine-IPM 2K samples at the correct frequency for most sources.

For best results, use a good test pattern such as a smooth gray consisting of a clear pattern of black and white pixels, or a similar “half on, half off” graphic image, such as the *Windows* shutdown screen. Adjust the slider until the vertical stripes broaden to the point where one large stripe fills the image. If the image still exhibits some shimmer or noise, adjust *Pixel Phase* (below).

Pixel Phase

*NOTE: Adjust Pixel Phase **after** Pixel Tracking.*

Adjust pixel phase when the image (usually from an RGB source) still shows shimmer or “noise” after pixel tracking is optimized. Pixel phase adjusts the phase of the pixel sampling clock relative to the incoming signal.

For best results, use a good test pattern such as a smooth gray consisting of a clear pattern of black and white pixels, or a similar “half on, half off” graphic image, such as the *Windows* shutdown screen. Adjust the slider until the image stabilizes and each pixel is clearly defined. You may notice that you can stabilize the image at more than one point—i.e., you may find that the image appearance at “11” is identical to the image appearance at “38”, thus you can use either setting.

If some shimmer from a video or HDTV source persists, use the “Filter” control to remove high-frequency noise from the signal.

H-Position

This option moves the image right or left within the area of available pixels.

NOTE: The value shown represents where the approximate center of the image lies in relation to the total number of pixels available horizontally. This varies widely according to the signal—watch the image while adjusting.

V-Position

This option moves the image up or down within the area of available pixels.

NOTE: The value shown represents where the approximate center of the image lies in relation to the total number of pixels available vertically. This varies widely according to the signal—watch the image while adjusting.

Advanced Size and Position — SUBMENU

This submenu consists of the following options:

Advanced Size and Position			
Active Input Window		1280 x 960	
1.	Top Blank	63	<input type="text"/>
2.	Bottom Blank	41	<input type="text"/>
3.	Left Blank	487	<input type="text"/>
4.	Right Blank	181	<input type="text"/>
5. Plug & Display <EDID>		Native Resolution 60Hz	

ACTIVE INPUT WINDOW: This read-only value indicates the current size (i.e., area) of your displayed data or “region of interest” as defined by the blanking controls. For example, if you have blanked (cropped) 100 pixels from both the left and right edges of an incoming source of 2048 x 1080, the remaining active input window will be 1848 x 1080. When using a video source at **INPUT 3** or **INPUT 4**, the default blanking of “0” defines an active input window of 720 x 483.

BLANKING (TOP, BOTTOM, LEFT, and RIGHT): Crop the image as desired so that unwanted edges are removed from the display (changed to black—see right). Blanking defines the size of the *Active Input Window*, creating an “area of interest”. Range of adjustment depends on the source resolution and other factors for your application.

NOTE: Blanking a PIP image resembles zoom (see Figure 3.12). For example, left blanking zooms the right side of the PIP image; Right Blanking zooms the left side. There are no black bars.

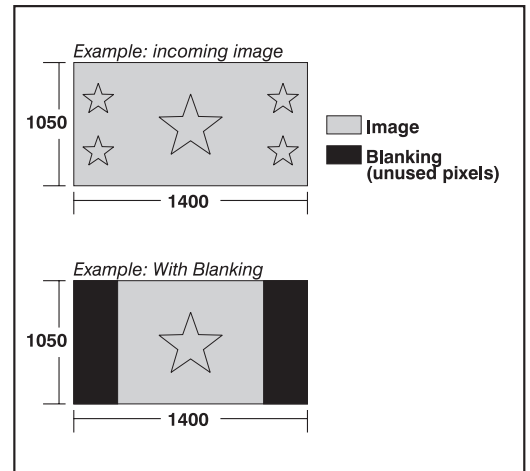

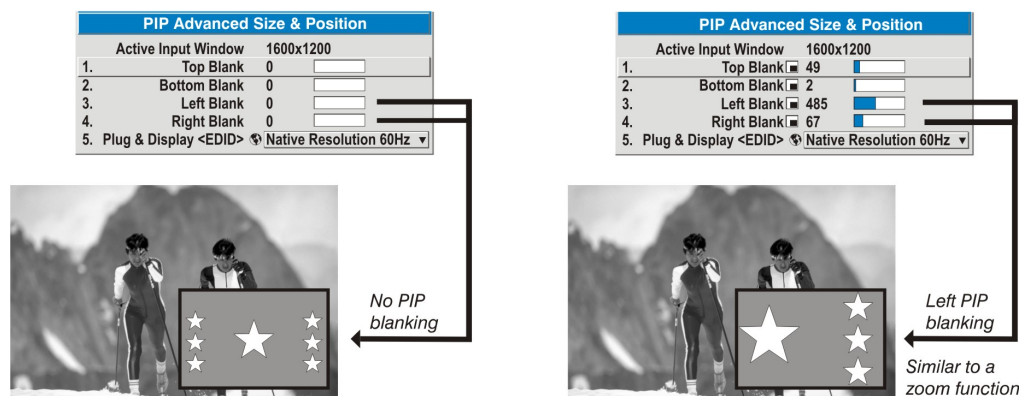

Figure 3.12. Blanking of a PIP Image

PLUG & DISPLAY (EDID): By default, a *Plug & Play (EDID)* source outputs a signal according to the EDID information provided by the *Cine-IPM 2K*. To override this information and display in a different format (for example, if your *Plug & Play [EDID]* device does not support the projector’s resolution and/or frequency), select the desired *Plug & Play (EDID)* resolution from the list.

- 1. Native Resolution 60 Hz
- 2. 1400 x 1050 60Hz
- 3. 720p (1280x720 60Hz)
- 4. DC2k (2048x720 60Hz)
- 5. 1024x768x116Hz 3D
- 6. 1280x1024x110Hz 3D
- 7. 1400x1050x102Hz 3D
- 8. 1080p 60Hz / 1080i 60Hz
- 9. 1080p 50Hz / 1080i 50Hz
- 0. 1080p 24Hz / 1080p 30Hz

Any daisy-chained *Cine-IPM 2Ks* will also display according to the chosen *Plug & Play (EDID)* format.

EDID = Extended Display Identification Data standard.

Image Settings Menu ⇒ Use options in the *Image Settings* menu to alter your non-cinema image without affecting its size or position. Changes made to the *Image Settings* menu are applied immediately and are saved when you exit the menu (press **Exit** or **Menu**). Options not available for the *Cine-IPM 2K* or source are disabled and appear dim (grey).

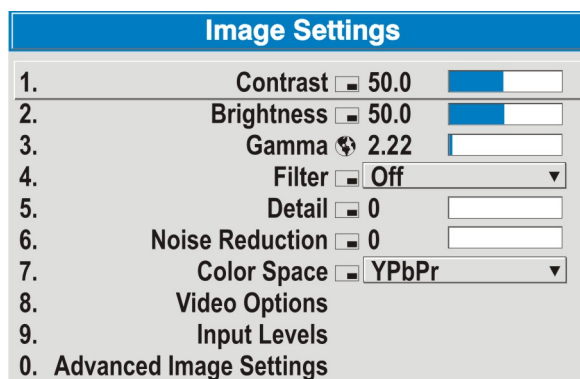

Contrast

(SHORT CUT: Press **Contrast** and adjust the slider.)

“Contrast” increases or decreases the perceived difference between light and dark areas of your image (0-100). For best results, keep close to 50. If contrast is set too high, the light parts of the image lose detail and clarity. If set too low, the light areas will not be as bright as they could be and the overall image will be dim. For best results, start with a low value and increase so that whites remain bright but are not distorted or tinted, and that light areas do not become white (i.e., are “crushed”).

*NOTE: If the environment lighting changes, an adjustment of **Gamma** is recommended (see below).*

Brightness

(SHORT CUT: Press **Bright**) and adjust the slidebar.)

“Brightness” increases or decreases the amount of black in the image (0-100). For best results, keep close to 50. Start with a high value and decrease so that dark areas do not become black (i.e., are “crushed”). Conversely, high brightness changes black to dark gray, causing washed-out images.

Gamma

“Gamma” is a global setting that defines what gray shades are displayed between minimum input (black) and maximum input (white) for all signals. A good gamma setting helps to optimize blacks and whites while ensuring smooth transitions for the “in-between” values utilized in other colors. Thus, unlike brightness and contrast settings controls, the overall tone of your images can be lightened or darkened without changing the extremes, and all images will be more vibrant while still showing good detail in dark areas.

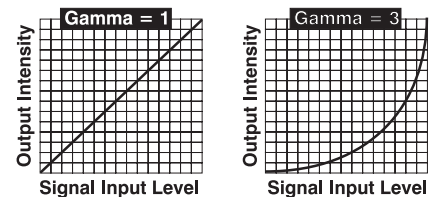

Gamma fine-tunes the gamma table currently in use, ranging from 1 – 3 (default = 2.22), indicating that the chosen gamma table has not been adjusted). If excess ambient light washes out the image and it becomes difficult or impossible to see details in dark areas, lower the gamma setting to compensate. This will improve contrast while maintaining good details for blacks. Conversely, if the image is unnatural with excessive detail in black areas, increase the setting. For more information, see Gamma Table. Again, look for contrast *and* good details in very dark areas.

Filter

The proper filter setting is automatically set for virtually all signals, and rarely needs to be changed. It applies a low pass filter for noise reduction in the incoming input signal, particularly for HDTV or SDTV. Applied in the analog domain before sampling, this filtering removes high frequencies and thus reduces pixel phase noise (note this also reduces signal bandwidth). Override only if standard pixel tracking and phase adjustments do not adequately clear up a “noisy” video signal, or if a graphics signal appears overly “soft”. Both instances indicate that “Filter” may be set to the wrong option.

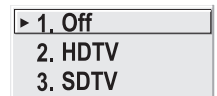

Detail

“Detail” adjusts the sharpness of a video image so that edges remain clearly defined. It can be particularly useful if a significant “Noise Reduction” adjustment has caused the image to appear too soft. Adjust until the display is as sharp as desired, keeping in mind that because “Detail” adds some high frequencies back into the image, it can also re-introduce a certain degree of noise.

Noise Reduction

Noise reduction is similar to the “Filter” control, but operates in the post-sampling digital domain with a more subtle effect. Higher settings are most useful for clearing up noisy RGB images such as those from a PC. Adjust as desired, keeping in mind that reducing noise (which reduces high frequencies) may also soften the image.

Color Space

“Color Space” determines how the color components of an analog input signal (or certain digital signals) connected to **INPUT 1, INPUT 2, INPUT 5** or **INPUT 6** are decoded for accurate color in the display. Although color space for these analog signals is automatically determined by the *Cine-IPM 2K*, in some circumstances you may wish to override this and manually set a specific color space.

- | |
|------------------|
| ▶ 1. RGB |
| 2. YPbPr (Video) |
| 3. YPbPr (HDTV) |

*NOTE: For most digital signals or for signals connected to **INPUT 3** or **INPUT 4**, the color space function is entirely automatic and the pull-down list disabled.*

The current color space appears in the *Image Settings* menu. Press **[Enter]** to select a different option:

- Select **RGB** *unless* you are using component video at **INPUT 1, 2, 5** or **6**.
- Select **YPbPr (Video)** with a standard definition televised signal (SDTV)
- Select **YPbPr (HDTV)** with a high definition televised signal (HDTV).

*NOTE: When certain RGB signals are first connected, the *Cine-IPM 2K* may not initially recognize them as RGB and will incorrectly decode their color information as YPbPr (video). These signals can include:*

- *RGB signals in NTSC, PAL, SECAM frequency ranges*
- *Scan-doubled sync-on-green*
- *Scan-quadrupled sync-on-green*

For these signals, change the Color Space to RGB, then define a new channel for future use.

Video Options — SUBMENU

This submenu is used with video sources only (**INPUT 3** or **4**).

ENABLE DECODER AGC: Automatic Gain Control affects decoded video images only. Enter a checkmark (default) in most instances—this activates the decoder’s AGC circuit to ensure properly bright images. Delete the checkmark if a decoded video image exhibits strange color artifacts such as stripes in highly saturated colors, indicating an incompatibility between this source and the AGC.

Video Options		
1. Enable Decoder AGC		<input checked="" type="checkbox"/>
2. Video Standard		<input type="text" value="Auto"/>
3. Input Video Black		<input type="text" value="0 IRE"/>
4. Color	<input type="text" value="50.0"/>	<input type="range" value="50.0"/>
5. Tint	<input type="text" value="50.0"/>	<input type="range" value="50.0"/>
6. Decoder Luma Delay	<input type="text" value="35"/>	<input type="range" value="35"/>

VIDEO STANDARD: For all but the more unusual video standards available in the world, the *Cine-IPM 2K* automatically detects the incoming horizontal and vertical frequencies and sets the *Cine-IPM 2K*'s processing of this signal to the corresponding standard. The current video standard name appears in the *Video Options* submenu, and includes an “A” if it has been auto-detected. Press **[Enter]** to view or select a different video standard from those available to the *Cine-IPM 2K*—any that are disabled have frequency characteristics that differ from those of the incoming signal. Selecting a specific standard forces the *Cine-IPM 2K* to process the signal according to this standard.

- 1. Auto
- 2. NTSC
- ▶ 3. NTSC 4.43
- 4. PAL
- 5. PAL-M
- 6. PAN-NC
- 7. PAL-60
- 8. SECAM

*NOTE: Best results are obtained with defined channels. Otherwise, switching from one video source to another can sometimes cause slight disturbances in the display, indicating that the **Auto** function is struggling. Recover by briefly selecting a different video standard, then going back.*

Table 3.3. Regions and Video Standards: Summary

Standard	Where Used (SUBJECT-TO-CHANGE)
NTSC	N. America and Japan
NTSC 4.43	A tape-only standard for partially-translated hybrid signals
PAL	Most of Europe, China, Australia, some of S. America, some of Africa
PAL-M	Brazil
PAL-NC	Argentina, Chile, other Latin American countries
PAL 60	
SECAM	France, Eastern Europe, most of Africa

NOTE: Generally, use “Auto” for all instances EXCEPT: 1) a poor quality input signal or 2) a black-and-white video signal or 3) an undefined channel. In order to detect and display correctly in these cases, select the relevant standard from the list.

INPUT VIDEO BLACK — This control compensates for incoming elevated black levels present in certain video signals, and ensures that blacks in the display are neither crushed (i.e., where dark grays appear black) nor excessively elevated (i.e., where blacks appear dark gray). By default, the *Cine-IPM 2K* automatically determines the best setting according to the type of incoming video signal:

If grays are black, select → **▶ 1. 0 IRE**

If blacks are gray, select → **2. 7.5 IRE**

- **0 IRE** – Used for DVD output with “enhanced black”, SECAM, most PAL standards, and Japanese NTSC.
- **7.5 IRE** – Used for most NTSC video signals.

For some types of video, you can override the setting. Generally, if black appears crushed when brightness = 50, choose “0 IRE”. If black appears excessively elevated, use “7.5 IRE”. The control is disabled for other types of video (and all graphics sources).

COLOR — This sidebar adjusts the color saturation level, i.e. the *amount* of color in a video image. Lower settings produce less saturated colors — for example a setting of “0” produces a black and white image. If the color level is too high, colors will be overpowering and unrealistic.

TINT — This sidebar adjusts the red/green color hue for true color reproduction of video and HDTV signals connected to Input 3 or 4. For best results, adjust tint while

displaying an external test pattern—otherwise, it is recommended that tint remain at its default setting.

DECODER LUMA DELAY – This control affects any incoming composite or S-video signal, delaying the luma signal (intensity) in relation to the chroma (color). In the image, increasing the luma delay will move luma (seen as a shadow where colors overlap) to the right slightly, with colors remaining in place. Decreasing this delay will move the shadow slightly to the left. If necessary for your current source, adjust so that no shadows occur with adjacent colors.

Input Levels — SUBMENU

*NOTES: 1) Because the Cine-IPM 2K automatically optimizes input levels for all but the most unusual of sources, it is recommended that only experienced users use the **Input Levels** submenu. 2) Before beginning, check that overall contrast and brightness settings are near 50 **and** that color temperature is properly set up on an internal grayscale test pattern. 3) There must be at least 6-12 consecutive white pixels present in the image for proper “Auto Input Level” function. Leave this control **off** after use.*

Good RGB or input levels—that is, the *drives* and *blacklevels* for each of the three colors, red, green and blue—ensure that images from analog sources other than decoded video have maximum contrast without crushing black or white. By default (and in an “Auto Setup”), the *Cine-IPM 2K* automatically determines the best input levels by monitoring image content and adjusting the controls appropriately—further adjustment is typically not required to obtain proper blacks or whites. *NOTE: This automatic adjustment requires at least 6-12 consecutive white pixels in the image. Without these pixels, input levels may produce skewed colors, particularly in non-video images.*

Input Levels			
1.	Auto Input Level	<input type="checkbox"/>	
2.	Red<Pr>Blacklevel	256	<input type="text"/>
3.	Red<Pr>Input Drive	256	<input type="text"/>
4.	Green<Y>Blacklevel	256	<input type="text"/>
5.	Green<Y>Input Drive	256	<input type="text"/>
6.	Blue<Pb>Blacklevel	256	<input type="text"/>
7.	Blue<Pb>Input Drive	256	<input type="text"/>
8.	Auto Color Enable	<input checked="" type="checkbox"/>	
9.	Clamp Location		Back Porch ▾
0.	Peak Detector	<input type="checkbox"/>	
	Color Enable		White ▾

Turn OFF before leaving menu.

Levels adjust automatically and correctly.



NOTE: Image must have at least 6-12 adjacent white pixels for “auto” to work.

However, for a very unusual source exhibiting one or more overly high blacklevels (typically caused by a noisy source causing blacklevel spikes), an experienced user may prefer to use the *Input Levels* menu (shown above). These adjustments, which together serve as a calibration process compensating for differences in sources and cabling, enable an experienced user to perfect the source image input levels and eliminate the “overshoot” and “undershoot”. Note that *Input Levels* are of limited use with digital signals, but do offer some ability to tweak poorly mastered source materials.

AUTO INPUT LEVEL – Keep off for virtually all sources (default). Temporarily enter a checkmark *only* if you are an experienced user and you have an unusual source that you feel needs further color temperature and/or input level adjustment. This compensates for incoming out-of-range drives (white) and blacklevels (black) that would cause “crushing” of light and dark colors in the image. After entering a

checkmark, wait for the six slider values to stabilize then delete the checkmark and exit. Auto Input Level should automatically turn off upon exit.

BLACKLEVELS AND DRIVES - To check your image and adjust these controls:

1. Make sure overall Contrast and Brightness are both set to near 50.
NOTE: Not required for “Auto” adjustment.
 -  = 50 (approx.)
 -  = 50 (approx.)
2. Check the color temperature setup using an internal grayscale test pattern, making sure to obtain a neutral grayscale. *NOTE: Not required for “Auto” adjustment.*
3. Confirm that you are using an analog source **not** connected to **INPUT 3** or **INPUT 4**, as Input Levels are not applicable for digital sources or sources going through the decoder. A grayscale is recommended.
4. If the blacks and/or whites appear OK, input levels do not need adjustment. If black levels are too high (and/or whites are too low, which is rare), you likely have a noisy source that is producing skewed input levels. Continue with Step 5.
5. Temporarily enable “Auto” in the *Input Levels* submenu. Wait for all 6 values to stabilize. Alternatively, do *not* use “Auto”—reduce blacklevels manually instead. Judge by eye and change one or more of the six levels as necessary to obtain proper blacks and whites. You may want to see only a certain color while adjusting—use the “Color Enable” option (described below).
6. Delete the “Auto” checkmark and leave the *Input Levels* menu.

IMPORTANT: *Do not use Input Levels to adjust color temperature. This will distort Contrast and Brightness functions as well as color temperature.*

AUTO COLOR ENABLE – When a checkmark is present, selecting a specific blacklevel or drive to adjust will automatically enable the corresponding color in the display. Delete the checkmark to see all colors.

CLAMP LOCATION – This option (formerly known as *sync tip clamping*) can brighten the image produced from certain high-resolution high-frequency graphic sources. For almost all sources, the best clamp location is automatically selected by the *Cine-IPM 2K*. Use the normal *Back Porch* location if the image is either sufficiently bright or overly bright. Select *Sync Tip* if the image appears unusually dim, if there are horizontal streaks across the image, or if there is significant color drift. This moves the clamping pulse from the normal backporch location (which is likely too short) to the tip of the horizontal sync pulse. *Tri Level* is typically recommended for an HDTV source where the back porch is also short.

- | |
|-----------------|
| ▶ 1. Back Porch |
| 2. Sync Tip |
| 3. Tri Level |

NOTE: Clamp Location is not used for video sources or any RGB source with sync information included on the video (e.g., sync-on-green). Use Tri Level instead.

COLOR ENABLE – Select which color or colors you want to see in the display, useful while working with color temperature white levels or input levels.

NOTES: 1) Input levels apply for the current source only, but for any color temperature used. 2) Assuming that color temperature has been set up based on the internal test patterns, you can then set up input levels for a given source so that it matches the color temperature of the internal test patterns.

PEAK DETECTOR – The Peak Detector is a fast method for defining individual input levels, and can improve the accuracy of input levels set by the Auto Input level function. Enabling the Peak Detector activates a special operating mode for detecting **only** pixels that are considered black or white—all other levels are displayed as a mid-level gray. When used with a smooth grayscale pattern in which black and white are known to be at opposite edges of the image, you can watch these isolated areas while adjusting individual blacklevels and input drives until both black and white edges are **just** visible and distinguished from neighboring pixels. Images from this source will then display correct blacks and whites without crushing or washing out.

See Figure 3.13. *Adjusting Input Levels Using the Peak Detector:*

- 1) Display a 16 level grayscale test pattern from the desired external source, and enter a checkmark in the Peak Detector checkbox. *NOTE: The “Peak Detector” will initially render the grayscale as a uniform gray field before adjustment.*
- 2) Display one primary color (use *Color Enable* to select).
- 3) For the current color, adjust its corresponding “Blacklevel” slider **just** until a single band of black appears at one edge of the screen. This band represents the first band of the grayscale pattern, which should be 100% black. Do not adjust too far.
- 4) With the same color still active, adjust its corresponding “Input Drive” slider **just** until a single band of color appears at the opposite edge of the screen. This band represents the last band of the grayscale pattern, which should be 100% white (or the current color, if a certain color is enabled). Do not adjust too far.
- 5) Go back and check the black band—adjust the blacklevel slider if necessary. Adjustments are related, so you may have to go back and forth until both bands are **just** optimized.
- 6) Repeat Steps 2-5 with the other two remaining primary colors. When each primary color shows **one** optimized black band and white (or colored) band, the input levels for this source are correctly set. Upon exiting the *Input Levels* menu, the Peak Detector checkbox will clear.

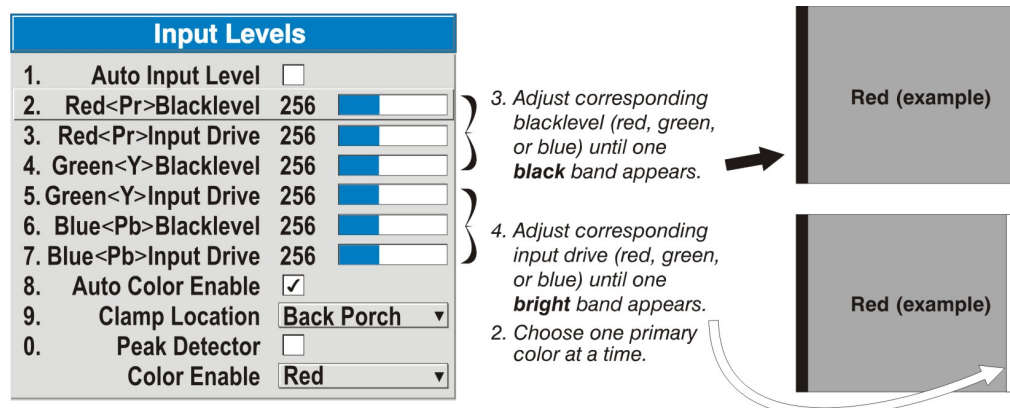
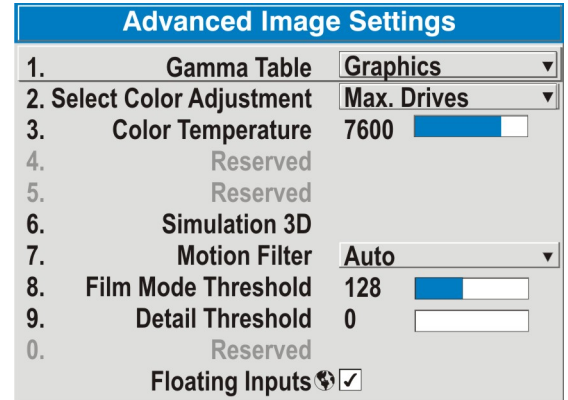

Figure 3.13. Adjusting Input Levels Using the Peak Detector (RED EXAMPLE SHOWN)

Advanced Image Settings — SUBMENU

Use the *Advanced Image Settings* submenu to adjust lesser-used options required only for more specialized applications.



GAMMA TABLE: This control applies a default *video* or *graphics* gamma table or “curve” to your images, controlling the intensity of midlevel colors while maintaining maximum contrast, brightness and color performance. As shown at right, the graphics curve is a simple power curve while the video curve has a linear segment near black to compensate for increased blacklevels typical of video signals.

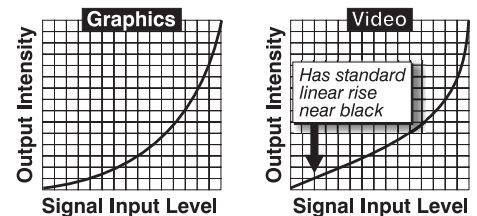

Although the *Cine-IPM 2K* automatically applies either the graphic or video curve according to what type of incoming signal is detected, in some cases you may wish to override this default and use *graphics* gamma for a video source or *video* gamma for a graphics source. Alternatively, if neither default is ideal, you may prefer to apply a user-defined custom gamma curve that has been created externally, named, and downloaded to the *Cine-IPM 2K* (requires separate PC-based *Arbitrary Gamma* and *KoRE Librarian* software applications). If any special user curves have been installed, their names will appear in the Gamma Table pull-down list.

Keep in mind that any Gamma Table choice sets the related Gamma value (shown in the *Image Settings* menu) to a 2.22 default, where it can be fine-tuned as desired. Different values (1-3) here indicate that the original gamma table has been adjusted with either the Gamma slider or direct key.

SELECT COLOR ADJUSTMENT: In “Select Color Adjustment”, choose an overall color performance for all non-cinema images. The “Max Drives” factory default simply drives all 3 colors at their maximum level so that they are fully on and cannot be changed. The two other pre-defined color adjustment choices—*SD Video* and *HD Video*—apply a color gamut optimized for non-cinema video sources (standard or high-definition). Alternatively, you can specify a color temperature, which enables the nearby Color Temperature slider and applies its current setting (default = 6500K).

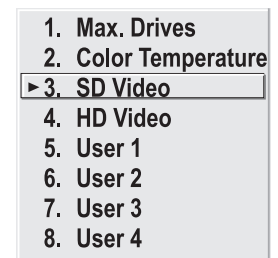

COLOR TEMPERATURE — Adjust to apply a specific color temperature to all displays. Color temperatures are expressed in degrees Kelvin (3200-9300K), and utilize different combinations of the projector’s original native color primaries to produce a “coloration” or cast (reddish or bluish) in images—the lower the temperature, the more reddish the cast; the higher the temperature, the more bluish the cast. Note that this slider is enabled only if you have a source connected and have selected “Color Temperature” in the adjacent “Select Color Adjustment” pull-down list.

RESERVED — No function.

Simulation 3D — SUBMENU OF ADVANCED IMAGE SETTINGS

Use the options in the *Simulation 3D* menu to make timing adjustments for realistic simulation environments.

FRAME DELAY MONITOR — This slider monitors the latency between input and output. For best results, the bar width and value should remain fairly constant, indicating that timing of input and output frames is locked; the Frame Delay Monitor value should stay within 5-10 lines or so of the Frame Delay setting. If a frame is lost or “dropped”, the bar will move suddenly and the values will change, indicating that the frame input is no longer equal to the output.

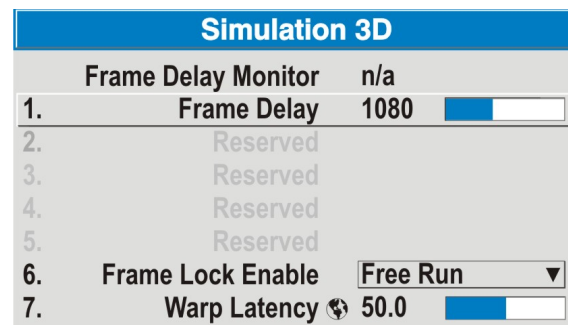

FRAME DELAY — Set the number of lines delayed between the input signal and its appearance on screen, keeping in mind that *Cine-IPM 2K* processing always *adds one frame of delay* to the frame delay setting. For applications such as simulation, where the feeling of “real time” image response is a priority, a minimum setting is usually preferable. If set too high or low, frame locking will not be possible—most sources require approximately 50 lines of delay to ensure frame locking.

RESERVED — No function.

FRAME LOCK ENABLE — When checked, the output image frame rate locks to the input signal frame rate when possible. When the images are not locked (recommended), the input and the output will run as close to the same rate as possible, but frames may occasionally be duplicated or dropped. For best results and stable images with v1.2 (or higher) software in the *Cine-IPM 2K*, leave unchecked.

WARP LATENCY — Requires optional *ChristieTWIST* module. See *ChristieTWIST User’s Manual* provided with the module.

Advanced Image Settings continued — SUBMENU

MOTION FILTER — This control is most useful for smoothing out moving images from interlaced sources. In most cases the proper Motion Filter setting is automatically determined according to the type of incoming source signal. However, if your source is noisy and/or inconsistent you may wish to “force” a setting to ensure stable processing for this source—if desired, override the default “Auto” setting by selecting the appropriate motion filter:

- 1. Auto
- ▶ 2. Still
- 3. Motion
- 4. Film

- 1) **AUTO:** The *Cine-IPM 2K* will automatically use the correct motion filter according to the incoming signal.
- 2) **STILL:** For static images with no motion, such as graphics from a CD.
- 3) **MOTION:** For video images that did not originate from film, or for moving computer-generated images.
- 4) **FILM:** For video images that originated from film. This will optimize image quality and stability.

FILM MODE THRESHOLD — This setting determines how sensitively the *Cine-IPM 2K* can detect if an incoming video signal originated from film or not.

DETAIL THRESHOLD — Use “Detail Threshold” to define at what frequency level the “Detail” control will begin to magnify high frequencies, which adds details back into the image. Raise the threshold to *ignore* more of these high frequencies, and lower the threshold to *magnify* more of these frequencies. A setting of “0”, for example, means no noise will be ignored and all will be magnified. An ideal detail threshold is one in which high frequencies that are causing objectionable noise are *not* magnified when using “Detail”, but frequencies which can help sharpen an overly-soft image *are* magnified when using “Detail”.

FLOATING INPUTS - This allows the signals connected to inputs 1, 3, and 4 to have floating ground references relative to the projector. Floating the inputs can remove hum bars in the image if the installation has conflicting grounds. However, floating the inputs can also introduce hum bars when the signal ground is the only connecting ground. Select the setting that produces the best image.

3.6 Adjusting System Parameters and Advanced Controls

Use the *Configuration* menu to define general operating parameters, processing and output, and communications with other *Cine-IPM 2Ks* or external equipment, and to access other advanced processing and image adjustments affecting overall performance. In addition, the *Configuration* menu provides access to diagnostics, calibration tools and the *Service* submenu (password-protected).

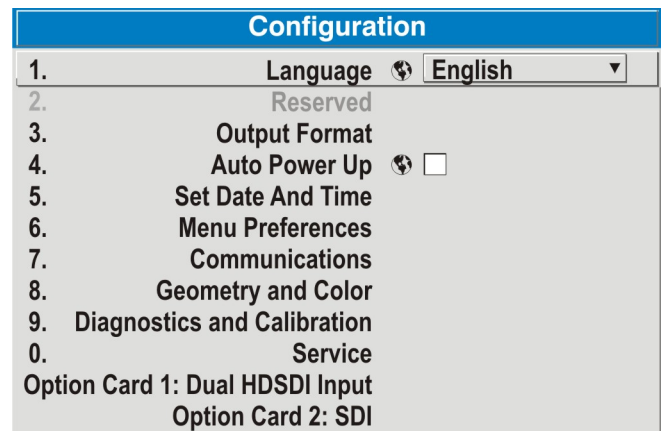

Figure 3.14. Configuration Menu

Keep in mind that settings in the *Configuration* menu (and its sub-menus) are typically “global” settings applied regardless of the type of source your are using. This characteristic is identified with the (globe) icon alongside the option.

NOTE: The **Configuration** menu is recommended for experienced users/technicians only.

System Configuration

— GENERAL —

► The first six options in the *Configuration* menu are explained below:

Language

Choose from available languages to use in the *Cine-IPM 2K* menus. The change will take effect immediately.

Reserved

No function.

Output Format

Use this submenu to control the output data sent by the *Cine-IPM 2K* to your display device. Choose between 8-bit and 10-bit data format, and specify the desired resolution for displays.

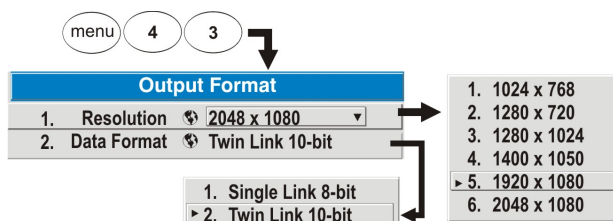

*NOTE: If you change resolution of your **Cine-IPM 2K** output, a dialog box will appear to remind you that the change will be implemented on the **next** power-up of the **Cine-IPM 2K**. Cycle the power if desired.*

Remember that *Cine-IPM 2K* outputs must be connected as shown in Figure 2.12. In addition, set the corresponding TPC controls for “Data Format” and “Source” to match both Output Format settings (refer back to Figure 2.20).

*NOTES: 1) v1.1 software may offer limited support for different resolutions in external devices. 2) 10-bit output improves displays of digital progressive source data. 3) Output Format settings apply for all of your *Cine-IPM 2K* sources.*

Auto Power-up

Enter a checkmark to enable the *Cine-IPM 2K* to automatically power up after losing power due to a power failure, or due to unplugging the *Cine-IPM 2K* during operation. Note that unsaved display adjustments may be lost.

Set Date & Time

Enter/read the current year-month-day and hour-minute-second. Changes here reset the projector’s real-time clock.

Menu Preferences — SUBMENU

Use the options in this submenu to adjust the appearance, content and/or location of on-screen menus and messages.

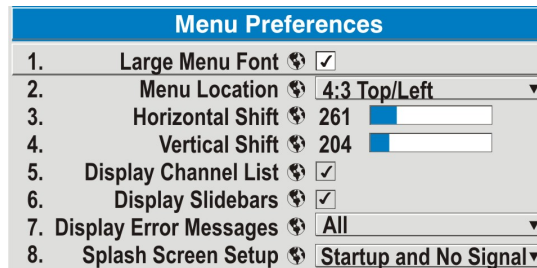

LARGE MENU FONT — Enter a checkmark to enlarge menus and their text. You may have to adjust “Menu Location” to accommodate the increased menu area.





MENU LOCATION — Use the pull-down list to choose a pre-defined default or customized location for the display of all on-screen menus.

To create a custom menu location quickly, choose a preset that is closest to the desired location. Then adjust the slidebars of *Horizontal Shift* and *Vertical Shift* to move the menu to the desired location. To prevent cropping of larger menus, avoid locations too close to a corner or edge.

HORIZONTAL AND VERTICAL SHIFT — Shift your menus as desired, creating a customized menu location.

DISPLAY CHANNEL LIST — Enter a checkmark if you want to see a scrollable channel list whenever you press ‘CHANNEL’ from your presentation. Channels marked with a list icon  in the *Channel Setup* menu will then appear here. The Display Channel List option also enables on-screen feedback when using the  key. If you prefer to hide the channel list and input dialog box while switching channels and sources during a presentation, clear the checkbox.

NOTE: The Channel List and input dialog box cannot be hidden during use of the menus.

DISPLAY SLIDEBARS — Enter a checkmark to superimpose a small sidebar over the current image whenever an adjustable parameter is selected directly with a key such as  or . If “Display slidebars” is unchecked, these slidebars can still be accessed, but will be hidden during adjustment. This option does not affect slidebars in menus.

DISPLAY ERROR MESSAGES — Choose how you want to be notified of errors detected in either the incoming signal or *Cine-IPM 2K*. Select “Screen” or “All” (default) to see brief on-screen messages. This is particularly recommended during setup or testing of your *Cine-IPM 2K* system. Or select “Serial Ports” to receive messages via RS232 (or RS422) serial communication only. To hide error message displays, such as during shows and presentations, select “Off” or “Serial Ports”.

SPLASH SCREEN SETUP — Use the Splash Screen to choose when you would like to display a special introductory splash screen image, such as your company logo, graphic or message.

- Always Off = A splash screen never appears
- Startup Only – The splash screen logo appears at projector startup only.
- Startup And No Signal– A splash screen appears at startup only if there is no source signal.
- Always On = A splash screen is always on behind the current display image, similar to wallpaper.

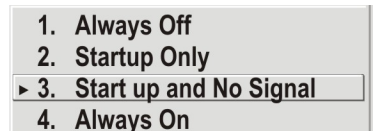

To replace the default “Christie logo” splash screen (or other) with one of your own, use [KoRE Librarian](#) to download the desired .bmp to the *Cine-IPM 2K*. This will overwrite the current splash screen content in *Cine-IPM 2K* memory.

System Configuration

— COMMUNICATIONS —

Settings in the *Communications* submenu define and control how single or multiple *Cine-IPM 2K*'s link with each other and with a controlling device.

Baud Rates

The baud rate setting determines the speed of communication to and from the *Cine-IPM 2K* on the RS232 or RS422 links. The maximum rate for either standard is 115200. Set the baud rate to match that of your controlling device, such as your PC. If you are unsure

about what baud rate to choose, refer to the documentation for the controlling device. In an existing network of *Cine-IPM 2Ks*, if you discover that a *Cine-IPM 2K* has a different baud rate, make sure to use the pull-down list and select the correct baud rate using the **Enter** key—do not just scroll this control with **Left** or **Right** keys. Serial communication is always 8 data bits, no parity.

Projector

Enter a three-digit number (such as "001") to assign or change a number to the *Cine-IPM 2K* currently in use. If the current *Cine-IPM 2K* already has a number assigned, that number will appear here (for example, "004" in Figure 3.15, above). Numerical identity for *Cine-IPM 2Ks* enables you to communicate with a single *Cine-IPM 2K* within a multiple-unit application (see also **Proj** key in 3.2, *Using the Keypad*). If you make a mistake in assigning or changing the projector (*Cine-IPM 2K*) number, press **Exit** to cancel.

Network Routing

Not applicable for stand-alone Cine-IPM 2Ks or simple serial networks with only one type of controller and linking.

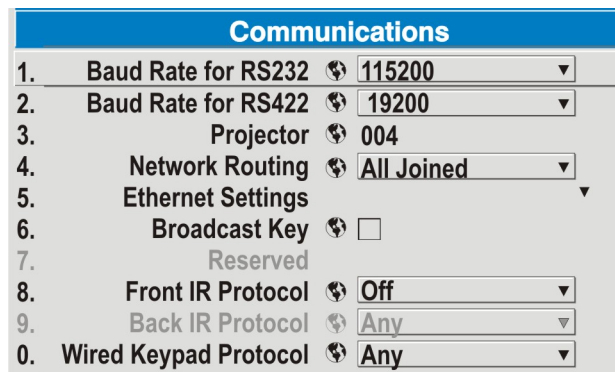

Figure 3.15. Communications Submenu

▶ 1. Separate	= Networks do not communicate with one another
2. RS232 and RS422 Joined	= Serial networks are joined, but Ethernet is isolated
3. RS232 and Ethernet Joined	= RS232 and Ethernet are joined but RS422 is isolated
4. All Joined	= Network communications travel all networks

SEPARATE: Select "Separate" (factory default) to keep RS232, RS422 and Ethernet messages on their respective paths instead of being broadcast to the remaining ports. In Figure 3.16A, RS422 controls only the *Cine-IPM 2K* to which it is connected. In Figure 3.16B; either RS232 or RS422 will control the network.

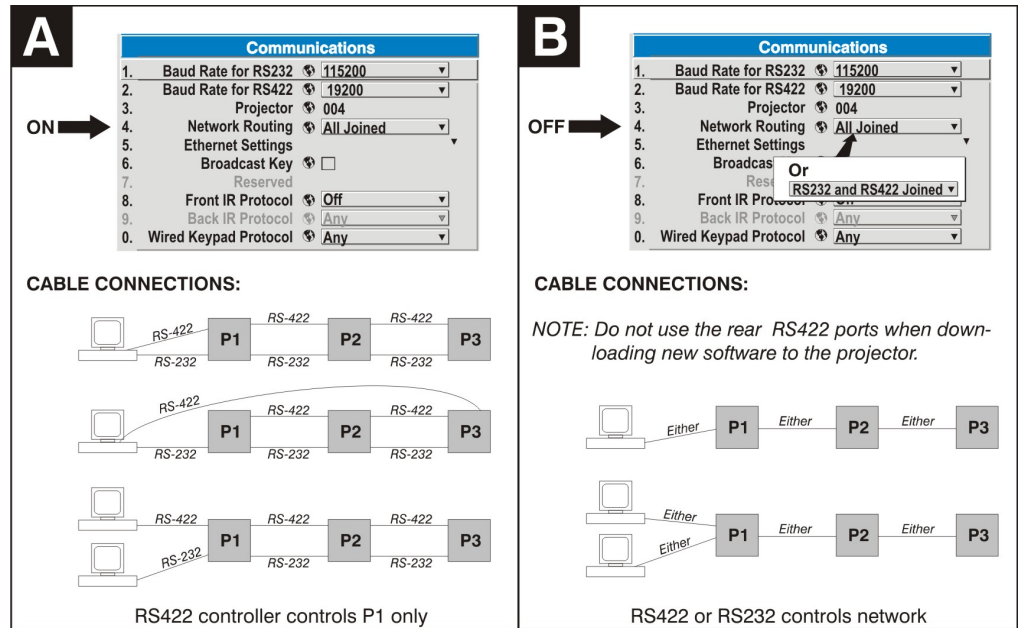

Figure 3.16. Using the “Network Routing” Option

RS232 AND RS422 JOINED: Messages to and from any serial port will also be relayed to all other serial ports. Use when there is only one physical link between any two projectors, but which might be RS232 or RS422.

RS232 AND ETHERNET JOINED: Messages to and from the RS232 ports will also be relayed to the Ethernet port, and vice versa. Any RS422 communications will be isolated.

ALL JOINED: All messages reach all ports, regardless of type.

Ethernet Settings (SUBMENU)

NOTES: 1) Not used for stand-alone Cine-IPM 2Ks. 2) Recommended for network administrators only.

DHCP: Enable this checkbox if you want a DHCP server to automatically set the Cine-IPM 2K’s IP address to one that is valid and unique for use on the current Ethernet network. On networks without a DHCP server, or to simply override the automatic DHCP server function, delete the checkmark and enter the new “IP Address” settings desired.

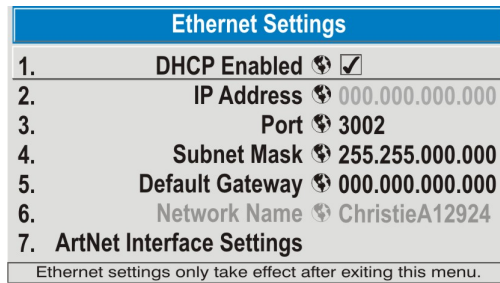

= Projector’s IP address will be DHCP-assigned
 = Use static address assigned in “IP Address”

IP ADDRESS: Enter a valid and unique IP address for use on the network to which the Cine-IPM 2K is currently connected. This address will overwrite any previous IP address such as the Cine-IPM 2K’s factory-defined default (0.0.0.0), or one that has been assigned by a DHCP server or other user. An IP address entered here is

implemented immediately and remains in effect until it is changed again. *NOTE: Make sure the Cine-IPM 2K is connected to the network before changing its IP address.*

PORT: On some Ethernet networks, firewall restrictions may require that the port number of the *Cine-IPM 2K* be changed from its default of 3002. If so, enter a new valid port number here. *NOTE:* It is recommended you do not use port numbers below 1000 as they are typically reserved by common IP applications.

SUBNET MASK AND DEFAULT GATEWAY: The Subnet Mask and Default Gateway are automatically assigned when DHCP is enabled. If a static IP address is used, assign it first since the subnet mask is estimated after it is entered. The Default Gateway allows you to specify the address of a local router, which enables the transmission of data between separate IP networks.

NETWORK NAME: Use this text box to assign a name to the projector to make it easier to identify on the local network. This is typically recommended when DHCP is enabled.

ArtNet Interface Settings – SUBMENU

ArtNet is an Ethernet communication protocol that was developed by Artistic License. It is used for controlling lighting/staging equipment from a lighting console or PC application. It is based on the popular DMX512 control protocol.

ArtNet Interface Settings		
1.	ArtNet Subnet	00
2.	ArtNet Universe	00
3.	ArtNet Advanced Mode	<input type="checkbox"/>
4.	ArtNet Base Channel	001
5.	ArtNet Device Name	Christie
6.	ArtNet Device Description	Christie / ArtNet

ArtNet SUBNET: This is the highest level address for a device. Typically it is set to 0.

ArtNet UNIVERSE: Each packet of data is broadcasted to all devices plugged into a universe (up to 512 devices/channels).

ArtNet ADVANCED MODE: If enabled, each projector listens for data on 64 channels starting with the base channel. When advanced mode is not in use, the projector only listens on 10 channels. You can squeeze more devices per universe when the projector used fewer channels. *NOTE: The additional 54 functions are not currently implemented and are reserved for future use.*

ArtNet BASE CHANNEL: When advanced mode is enabled, the projector listens to data on 64 consecutive channels, or 10 consecutive channels when advanced mode is not enabled. The projector processes requests that come on either 10 or 64 consecutive channels beginning with the “base channel” defined here. The requests implement the following functions:

DMX Channel	Function	Value	
Base	Shutter	0 – 64 65 – 192 193 – 255	Open No Action Closed
Base + 1	Slider Lock	0 – 254 255	Locked Unlocked *
Base + 2	Input *	1 – 8	Input #
Base + 3	Channel *	1-99	Channel #
Base + 4	Lens – Vertical * †	0 1 – 254 255	Lens Down Stop Lens Up
Base + 5	Lens – Horizontal * †	0 1 – 254 255	Lens Right Stop Lens Left
Base + 6	Lens – Focus * †	0 1 – 254 255	Negative Focus Stop Positive Focus
Base + 7	Lens – Zoom * †	0 1 – 254 255	Zoom Out Stop Zoom In
Base + 8	Power *	0 1 – 254 255	Power Off No Action Power On
Base + 9	None		

* Functions are only active when the Slider Lock is set to Unlocked

† Lens functions have no effect on the Roadie 25k

NOTE: It is important to make sure the channels DO NOT overlap another device.

Example:

Good	Bad
Proj1 Base = 0	Proj1 Base = 5
Proj2 Base = 10	Proj2 Base = 9
Proj3 Base = 20	Proj3 Base = 11

ARTNET DEVICE NAME: This option is used to name each device; some ArtNet servers support querying for devices. Press Enter and use the arrow keys to enter a name. *NOTE: Refer to section 3.3 Navigating the Menus, Edit numerical Values, for text entry description.*

ARTNET DEVICE DESCRIPTION: More information that is returned when a “device query” has been done.

Broadcast Key

Enter a checkmark if you want keypad commands sent to one *Cine-IPM 2K* to be relayed to all *Cine-IPM 2Ks* in a serial network. Note that the  key will temporarily “override” the effect of a broadcast setting and allow you to control a specific *Cine-IPM 2K* when necessary. Make sure to remove the Broadcast Key checkmark when operating redundant networks.

Front IR

This option determines whether or not the IR sensor on the *Cine-IPM 2K* responds to the IR remote keypad. To disable this sensor, you must use a wired remote keypad to select the “Front IR” **OFF** setting. This safeguard prevents accidentally disabling a keypad during use. When off, the *Cine-IPM 2K* will no longer respond to an IR remote keypad.

*NOTE: See 2.7, **Converting the Keypad** for information about changing your keypad from IR to wired, or vice versa.*

Wired Keypad

This option determines whether or not the wired keypad on the *Cine-IPM 2K* responds to signals arriving at the “**REMOTE**” port on the *Cine-IPM 2K* front panel. To disable this option, you must use an IR remote keypad to select the “Wired Keypad” **OFF** setting. This safeguard prevents accidentally disabling a keypad during use. When off, the *Cine-IPM 2K* will no longer respond to a wired keypad connected at the front panel.

System Configuration — GEOMETRY and COLOR —

In the *Configuration* menu, select the *Geometry and Color* submenu when you need to modify general color performance and/or image geometry for all sources.

Test Pattern

Choose the desired internal test pattern to display, or select OFF to turn off a test pattern. Alternatively, use the  key for cycling through test patterns.

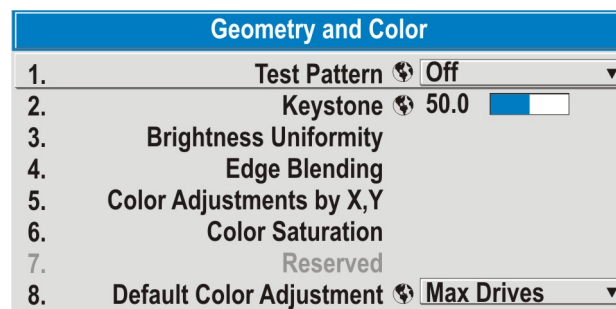

Keystone

*NOTE: If the optional **ChristieTWIST** module is installed, this option is **Keystone and Warping**, and activates a submenu for defining custom image shapes. Please refer to the documentation included with your **ChristieTWIST** module.*

Use to correct a keystoneed image in which both sides of your image are inclined toward each other. Keystone is typically caused by tipping the projector in relation to the screen, so that the lens surface and screen are no longer parallel to each other.



Figure 3.17. Keystone Adjustment

Brightness Uniformity — SUBMENU

Brightness Uniformity creates an exceptionally smooth image in which no area appears brighter and/or more red, green or blue than another. It is typically used to further refine multiple displays already matched for their primary colors and overall light output, but this feature can also smooth out a single image. In the *Brightness Uniformity* menu, enable the “Uniformity Enable” checkbox to access a multitude of adjustments for critical color light output control in specific areas throughout the image. Your settings apply as long as the “Uniformity Enable” checkbox is enabled and you are using a “User” color temperature defined by the Brightness Uniformity controls. To disable the Brightness Uniformity function, delete the “Uniformity Enable” checkmark.

*NOTES: 1) See also 3.11, **Using Multiple Cine-IPM 2Ks** for the complete step-by-step procedure for achieving uniform brightness. 2) If **ChristieTWIST** is installed, the*

enable checkbox changes to a list giving the option to choose from several different uniformity maps. Refer to the documentation provided with the ChristieTWIST.

Edge Blending — SUBMENU

The *Edge Blending* submenu provides a range of controls for smoothing together the overlapping bright edges of multiple adjacent projected images to create a single larger “seamless” image. These controls, which primarily affect whitelevels, are typically used in conjunction with mechanical lens blinders (optional), which are installed on the front of the projector and which primarily affect blacklevels. Blinders for this projector are not yet available.

NOTE: See also 3.11, Using Multiple Cine-IPM 2Ks for the complete step-by-step procedure for blending edges between adjacent non-cinema displays.

Color Adjustments by X/Y, and Color Saturation — SUBMENU

*NOTES: 1) For defining or changing a User 1, 2, 3, or 4 color performance or “gamut”. Sometimes known as Comprehensive Color Adjustment™. 2) Factory-defined primary color levels can be altered in the **Service** menu only. If you suspect alteration of these defaults, the factory settings can be recovered with selection of “Reset to Factory Defaults?” in the **Color Primary Settings** submenu accessed via the **Service** menu (password-protected). 3) Independent of CP2000 TCGDs.*

From the factory, the *Cine-IPM 2K* can utilize any of the three pre-defined color performance settings identified at right (default=Max Drives), or colors can be driven on the basis of color temperature. For most applications, one of these gamuts will produce accurate and realistic colors from a variety of sources. They can be applied at any time in the *Advanced Image Settings* menu (“Select Color Adjustment”), and are not adjustable.

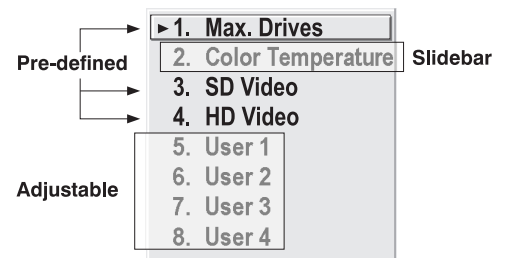

Figure 3.18. Color Gamut Choices

DEFINING “USER” COLOR GAMUTS: In some cases, you may find that none of the pre-defined “Select Color Adjustment” options exactly suit your needs. For example, you may require a unique color gamut (range) for a single projector or non-cinema application, or you may need to precisely match colors across multiple adjacent non-cinema displays. In such cases, use the *Color Adjustments by X,Y* or *Color Saturation* submenu to define the precise *hue* of each primary color component (red, green, blue, and white) used to generate the millions of colors produced in displays. You can create up to four custom color gamuts (User 1, 2, 3, or 4) with these adjustments.

Note that the two menus differ only in their user interface, so use whichever menu best suits your needs and application. A color meter can help with adjustments.

- *Color Adjustments by X,Y* — Enter known x/y coordinates from the chromaticity graph.
- *Color Saturation* — Adjust color slidebars and judge image color by eye or meter.

A user-defined color “adjustment” can be applied for a source by selecting the desired “User” option in the “Select Color Adjustment” list accessed in the *Advanced Image Settings* menu.

COLOR ADJUSTMENT BY X,Y: Use this submenu if you want to create, alter or copy a color gamut (i.e., “color adjustment”). Controls in this menu define the precise hue of each primary color component (red, green, blue, and white) used to generate the millions of colors outputted to display devices. The x/y coordinates for each color define its location on the standard CIE chromaticity graph (see Figure 3.20)—changing either or both of these numbers will change the hue of the color, and relocate the “triangle” for possible colors. For example, changing the x/y coordinates for red may move the color closer to orange or closer to violet, which will in turn affect all displayed colors having a red component. Adjust the sliders or enter new specific coordinates as desired to define or change up to four “User” color gamuts needed for your environment and applications. Apply at any time in the *Advanced Image Settings* menu. **NOTE:** *If x/y coordinates are out of range the Color Space Valid Valid will change to Color Space Valid Error.*

Color Adjustments by X,Y			
1.	Select Color Adjustment	User 2	▼
2.	Color Temperature	6500	<input type="text"/>
Color Space Valid Valid			
3.	Red X	0.655	<input type="text"/>
4.	Red Y	0.341	<input type="text"/>
5.	Green X	0.332	<input type="text"/>
6.	Green Y	0.575	<input type="text"/>
7.	Blue X	0.144	<input type="text"/>
8.	Blue Y	0.093	<input type="text"/>
9.	White X	0.320	<input type="text"/>
0.	White Y	0.330	<input type="text"/>
Auto Color Enable		<input checked="" type="checkbox"/>	
Color Enable		Red	▼
Copy From		Max Drives	▼

Figure 3.19. Customize Color

Adjust the sliders or enter new specific coordinates as desired to define or change up to four “User” color gamuts needed for your environment and applications. Apply at any time in the *Advanced Image Settings* menu. **NOTE:** *If x/y coordinates are out of range the Color Space Valid Valid will change to Color Space Valid Error.*

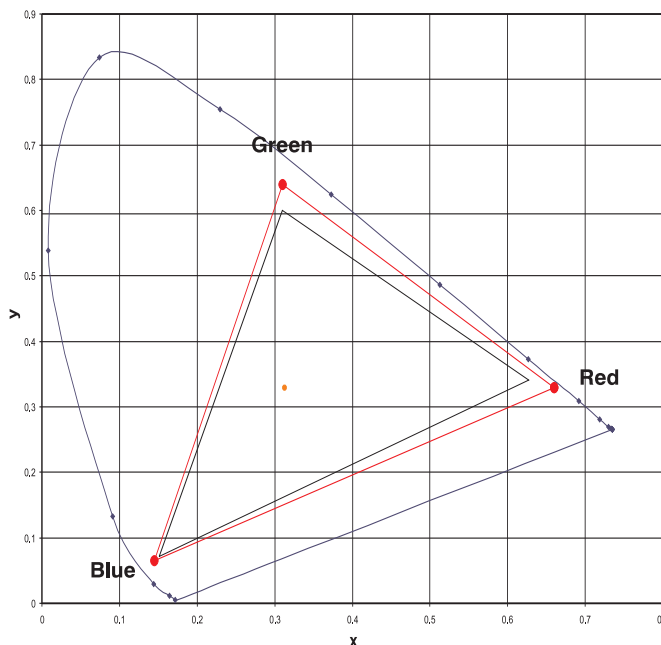

Figure 3.20. CIE 1931 Chromaticity Diagram

NOTE: *Keep new x,y coordinates within the original color gamut triangle shown here.*

PROCEDURE FOR X,Y ADJUSTMENTS: See 3.11, Using Multiple Cine-IPM 2Ks.

COLOR SATURATION: Use this submenu if you do not have specific color coordinates in mind and will simply judge color performance by eye or meter. Like the *Color Adjustment by X,Y* submenu, each color control actually defines new x/y coordinates for that color and changes its hue—it is just a different interface.

Adjust the hue of each primary color (red, green, blue, and white) by using more or less of it in relation to the other colors.

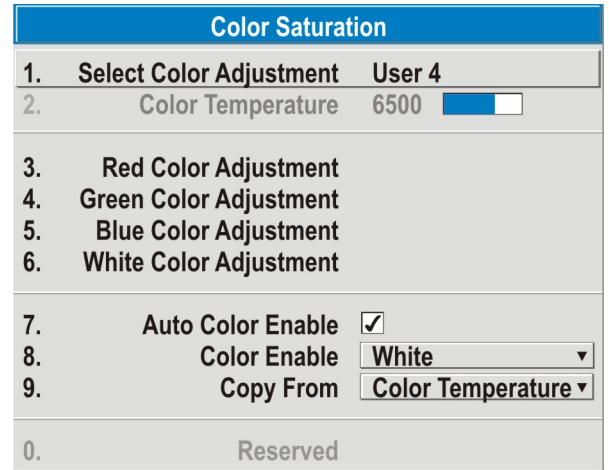

Figure 3.21. Customize Color

NOTE: A Color Saturation adjustment defines the corresponding x/y coordinates shown in the Color Adjustment by X,Y submenu. These x/y coordinates will remain stable for this User gamut until they are changed again via either menu. Values displayed in the Color Saturation menu, however, will likely fluctuate as you use the projector, and will be different when you return to this menu at some point in the future. These floating changes do not affect the x/y coordinates or gamut.

Default Color Adjustment

This specifies the default color adjustment that will be applied to each new channel. If required, you can override this setting for a specific channel.

System Configuration
DIAGNOSTICS / CALIBRATION

Test Pattern

Choose the desired internal test pattern to display, or select OFF to turn off a test pattern. Alternatively, use the  key for cycling through test patterns.

Test Pattern Grey Level

Set the desired level of grey for displaying in the full grey field test pattern.

Freeze Image

Enter a check mark to freeze (stop) an image at a single frame. This diagnostic tool is useful if you need to examine in detail a still version of an incoming image that cannot be “frozen” at the source. For example, in moving images it is sometimes difficult to observe artifacts such as external deinterlacing/resizing and signal noise. Remove the checkmark to return back to normal.

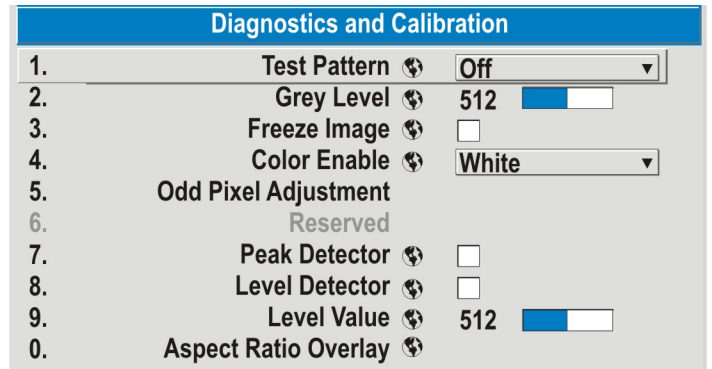

Figure 3.22. Diagnostics and Calibration

Color Enable

Select which color or colors you want to see. This is useful while working with color temperature, input levels or other special setup parameters. Colors can also be enabled/disabled by entering the corresponding function code (see “Function Key”).

Odd Pixel Adjustment

NOTES: 1) Factory-set and rarely required by user. 2) Source must be >90 MHz.

When using certain non-cinema RGB sources, you may need to adjust the normal gain or offset of odd pixels in relation to even pixels. This will smooth out very narrow (1-pixel wide) “checks” or vertical stripes that indicate adjacent “on” and “off” pixels. Although offset and gain slidebars can be adjusted individually and manually, using the Level Detector simplifies this process (see Figure 3.23):

- 1) Use an external analog native-sized continuous grayscale test pattern with at least 256-levels.
- 2) Turn “Level Detector” on.
- 3) Set “Level Value” to **~200**. The image should now be black-and-white (or black-and-one color, if you use “Color Enable” function).
- 4) Adjust **offset**. Half of the pixels will move, the other half will not.
- 5) Adjust until the two transition regions overlap. The stripe of noise will be minimized, defined by the value in the slidebar.
- 6) Set “Level Value” to **~800**. The image should now be black-and-white.
- 7) Repeat Steps 4 and 5, but adjusting **gain**.
- 8) Repeat Steps 3-7 for all remaining colors. Your RGB source should now be OK.

Two sets of values are automatically saved with this process—one value for **INPUT 1**, and one value for **INPUT 2** (analog). The *Cine-IPM 2K* will automatically choose the correct set depending on the source connection. This enables a single source to be processed correctly whether it routes through one input or another.

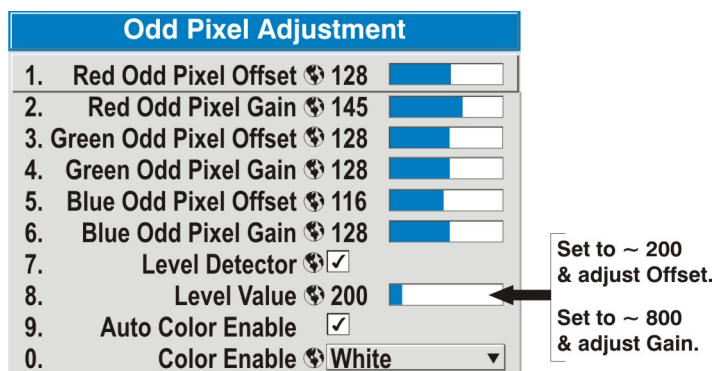

Figure 3.23. Using “Odd Pixel Adjustment”

NOTES: 1) Adjust offset before gain, since offset affects gain. 2) A value of 128 represents no change in normal odd pixel offset or gain. 3) Odd Pixel Adjustment eliminates “1 pixel on, 1 pixel off” patterns only, not any type of larger patterns.

Reserved

No function.

Peak Detector

The Peak Detector is fast method of defining individual input levels, and can improve the accuracy of input levels set by the Auto Input level function. Enabling the Peak Detector activates a special operating mode for detecting *only* pixels that are considered black or white—all other levels are displayed as a mid-level gray. When used with a 16-step grayscale pattern in which the two black and white bands are known to be at opposite edges of the image, you can watch these isolated areas while adjusting individual blacklevels and input drives until both bands are just visible. Images from this source will then display correct blacks and whites without crushing or washing out.

Level Detector

The Level Detector checkbox enables a specific thresholds for blacks and whites—input levels that fall below a specified *Level Value* (see below) are displayed as black, and all others are displayed as white. It aids in Odd Pixel Adjustment. To use:

1. Enable Level Detector and display a continuous grayscale.
2. Set *Level Value* to near black (such as 200).
3. Adjust Offsets to minimize area of black stripe.
4. Set *Level Value* to near white (such as 800).
5. Adjust Gains to minimize area of white stripe.

Level Value

The *Level Value* defines the value to be used by the Level Detector in recognizing blacks and whites. See *Level Detector*, above.

Aspect Ratio Overlay

When selected, this option will display outlines ovetop of the image in various aspect ratios. This is useful when trying to position images.

System Configuration

OPTIONAL INPUT MODULES

The two “Option Card” entries in the *Configuration* menu identify which optional input modules (a.k.a. *cards*) are present at **INPUT 5** (Option 1) and **INPUT 6** (Option 2). If either of these option slots is empty, the corresponding read-only menu entry does nothing. If there is a module installed, the corresponding menu entry may activate a submenu of further options pertaining to that module.

For example, if the *Dual SD/HD-SDI* module is installed at **INPUT 5** (Option 1 slot), the Option 1 Card submenu

provides controls for configuring the various connections on this multi-input, multi-output module—see Figure 3.24. As desired for your application, you can define 1) which physical input loops through to which output, and 2) which functional input (main or PIP signal) loops through to which output.

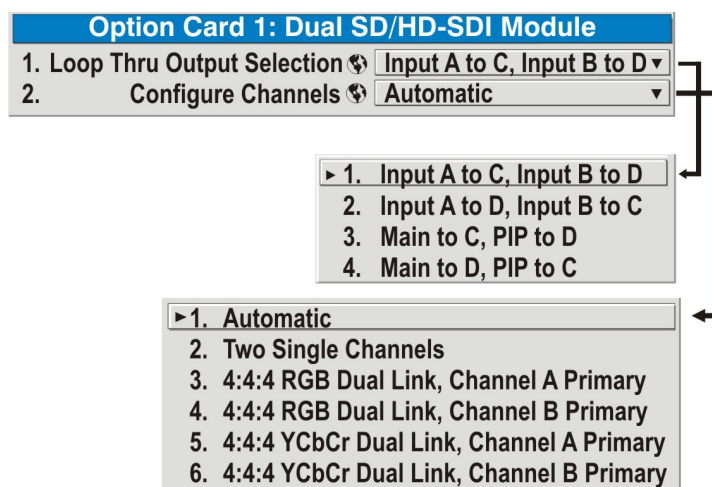

Figure 3.24

3.7 Working with PIP or Switching

NOTE: Smooth or Seamless switching not currently supported for 2048 x 1080 or 1920 x 1080 output from the Cine-IPM 2K.

PIP (Picture-in-Picture) and Switching are independent but related *Cine-IPM 2K* features that both utilize two image processing paths within the unit. In the case of Picture-in-Picture, this double processing enables you to output two different images simultaneously – typically a smaller “secondary” image within a large “primary” background. In switching (available with certain *Cine-IPM 2K* outputs), the double processing essentially occurs *between* displays so that a full image relayed from one source can smoothly transform into a full image from another source. This change can be virtually instantaneous, or slowed as desired so that the current image appears to dissolve or “fade” into the new image.

Options for enabling and controlling PIP and Switching all reside in the same menu. Note, however, that because both features utilize the *Cine-IPM 2K*’s double processing capability, PIP and Switching cannot be used together. For example, fading a pair of PIP images into a new display from a different source is not possible.

For best PIP or Switching results, use two *different* signal types* as defined below. Do not mix two signals of the same type.

Signal Type	Description (Input Location)
#1	5 BNCs (RGBHV or YPbPr)
#2	DVI - I (analog or digital)
#3	Decoded signals (Input 3, Input 4, Composite video, S-Video, or any video signal via Input 1 BNC connectors or via an analog option card).
#4	Analog Option Cards
#5	Digital Option Cards
#6	Digital Option Cards

* HD interlaced sources are not recommended for the PIP window.

Other PIP or Switching tips to keep in mind include:

- When using two digital signals or one analog and one digital, each must be ≤ 165 megapixels.
- When using two analog signals, each must be ≤ 90 megapixels.
- Avoid using an interlaced source in the PIP window
- Switching is not supported with *Cine-IPM 2K* outputs of 1920 x 1080 or higher, and may affect image quality in some cases.

Working with PIP ► *NOTE: Controls for the primary image are all accessed through the **Main** menu. To control the secondary (PIP) image, access picture controls through the **PIP and Switching** menu.*

Use the first of six options in the *PIP and Switching* menu to enable and define how you want to use PIP.

Options 8 and 9 pertain to source switching only, and are supported with the *Cine-IPM 2K*'s output of SXGA+ or lower.

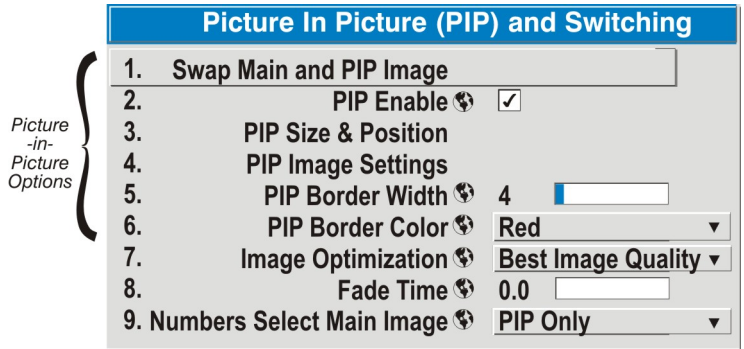

Swap Main and PIP Image

Toggle the current picture-in-picture relationship so that the primary (main) image becomes secondary (PIP), and the secondary image becomes primary. Swapping is available only when PIP is enabled.

NOTE: There may be a slight delay when swapping the Primary and Secondary images.

PIP Enable

(SHORT CUT: Press  from your presentation.)

Toggle to display from two sources at once (Picture-in-Picture) or the primary source only. This checkbox turns the secondary source on and off.



NOTE: Disable PIP for Interlaced sources > 35kHz.

PIP Size and Position – SUBMENU

Controls in the *PIP Size and Position* menu affect the PIP (secondary) image, functioning in the same manner as the main controls in the *Size and Position* menu—see 3.5, *Adjusting the Image* for descriptions.

Additional options unique to the PIP image are:

POSITION PRESETS—Set the location of the PIP (secondary) image in the display.

ASPECT RATIO PRESETS—Set the desired aspect ratio of your PIP image to “Default” or “Anamorphic”. Refer back to 3.5, *Adjusting the Image (Resize Presets)* for details.

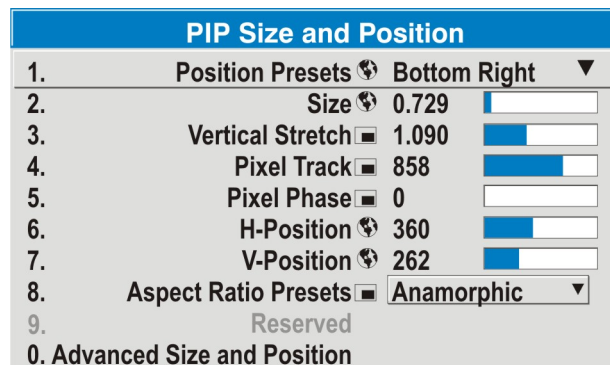

PIP Image Settings — SUBMENU

Adjust the PIP (secondary image) without affecting the size or position. The primary image remains unchanged. See 3.5, *Adjusting the Image* for details.

PIP Border Width

Set the desired line thickness for your PIP window border.

PIP Border Color

Select the desired color for the PIP window border.

Working with Switching ► Switching is the ability to instantly and/or smoothly switch sources, and is controlled with options 7 and 8 in the PIP and Switching menu. To use Switching, PIP must be disabled and the *Cine-IPM 2K* output set to a resolution that is less than 1920 x 1080.

Image Optimization

Choose whether to switch sources as smoothly as possible, or whether you prefer to optimize image quality, whichever best suits your needs. Select “Best Image Quality” to improve raw image quality while maintaining 10-bit processing; however in some cases when switching between sources, you may notice a brief dark state between images. Select “Smooth Switching” to maintain the ability to frame lock. This is best suited for when switching between video sources. In some instances, you will notice a brief dark state between images. If you are not concerned with frame locking select “Seamless Switching. This will set the output to a fixed frame rate (60Hz). Switching occurs almost instantaneously without a dark state in between images. *NOTE: With Smooth and Seamless Switching, Cine-IPM 2K output must be less than 1920 x 1080.*

Fade Time

Set how long (in seconds) it takes to gradually dissolve one image into another for a source switch. Fading is available for single-image “best” source switching only—PIP cannot be in use, and Image Optimization must be set to “Smooth Switching”.

NOTE: Fade Time is not currently supported for 2048 x 1080 or 1920 x 1080 outputs.

Numbers Select Main Image

Use *Numbers Select Main Image* to use the numeric keys #1-8 as input keys. This remapping of the keypad (see right) can be particularly useful with PIP displays, providing a convenient shortcut for changing the primary (background) image without first having to return to the *Main* menu. To use the keys in this manner all of the time, even with single *Cine-IPM 2K* displays, select *Always*. For normal keypad function, select *Never* (default). Set to “*When PIP Active*” to activate number keys as input keys only when PIP is in use.

- ▶ 1. Never
- 2. When PIP Active
- 3. Always

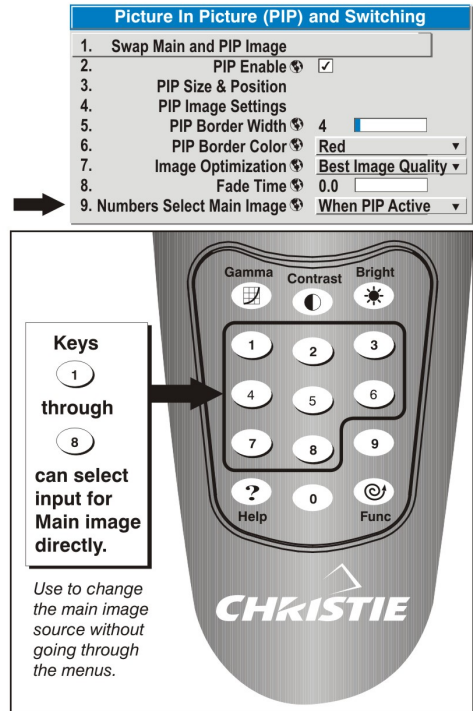

Figure 3.26. Keypad Remap

NOTE: Numbers Select Main Image keypad functionality works only when menus are closed

3.8 Status Menu

Refer to the *Cine-IPM 2K*'s read-only *Status* menu to determine what versions of hardware and software are installed in the *Cine-IPM 2K*, and what its serial number is. The *Status* menu also identifies the current channel, its input location, frequencies and other details. If your *Cine-IPM 2K* is connected via RS232 “B” to the *CP2000* projector, the *TPC Status* page also provides similar *Cine-IPM 2K* status information.

Scroll the full *Status* menu using . Use for page up/down.

3.9 Cine-IPM 2K Source Selection via TPC



NOTE: In all cases, the Cine-IPM 2K's RS232 “B” port must be connected to the CP2000.

USING THE TPC ONLY: If your *Cine-IPM 2K* is connected to the *CP2000* via **DVI-1** you can use the TPC for a quick single-step switch to a specific *Cine-IPM 2K* non-cinema input #1-6. This source must first be configured for TPC use in the *Custom* menu of the TPC as described in 2.5, *Setting Up the TPC for Source Selection*—then select this button at the *TPC Main* menu. Use and/or on the keypad to refine *Cine-IPM 2K* display settings as desired.

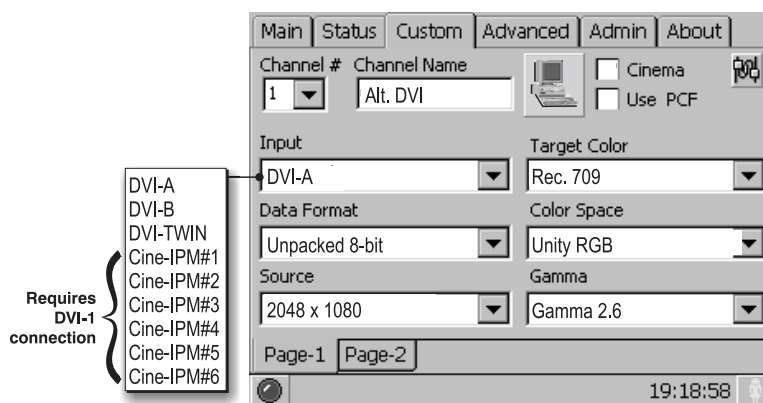

Figure 3.27. “Input” Location and Cine-IPM 2K Source Selection

WHEN THE REMOTE KEYPAD IS REQUIRED: If your *Cine-IPM 2K* is connected via **DVI-2** or if you are using 10-bit mode, you must use the remote keypad for selection of the specific input#—i.e., you cannot select a specific *Cine-IPM 2K* input 1-6 at the TPC Main menu.

- **If connected via DVI-2:** *Cine-IPM 2K* output arriving at the *CP2000* **DVI-2** port cannot be identified by its input number (1-6). The button must be configured simply as “DVI-2” input in the *Custom* menu. When this button is selected, you must then use the remote keypad to select (Input 1), (Input 2), (Input 3), (Input 4), (Input 5) or (Input 6) as desired.
- **If using 10-bit mode:** The TPC button must be configured as “DVI-TWIN” input in the *Custom* menu, otherwise you will not be in 10-bit mode. When the button is pressed, you must then use the remote keypad to select (Input 1), (Input 2), (Input 3), (Input 4), (Input 5) or (Input 6) as desired.

3.10 Remote Control of the *Cine-IPM 2K*

As an alternative to using the keypad, *Cine-IPM 2K* functions can be controlled remotely, typically at a controller such as a PC, via 1) simple bi-directional ASCII messaging on a serial or Ethernet communication link or 2) a web interface or “ChristieNET” on an Ethernet network.

VIA ASCII MESSAGING — Connect a serial link (recommended) between your controller and the **RS232 IN** port (or **RS422**, if available from your controller). Alternatively, open an Ethernet socket—such as Telnet—between your controller and the valid *Cine-IPM 2K* address. Valid ASCII codes and messages are documented in the *Christie Serial Communications* document available at the Christie website.

VIA WEB INTERFACE — Connect your PC to the *Cine-IPM 2K*’s Ethernet port. In your web browser (Internet Explorer, for example), enter the IP address of the *Cine-IPM 2K*. This will start a password-protected ChristieNET application—enter the factory default “**ccm7**” login and password to open the program. If the *Cine-IPM 2K* is powered up, you can access assorted menu options and slidebars.

Repeat for remaining networked *Cine-IPM 2Ks* as desired. Keep in mind that multiple units can be controlled from one PC, but each unit will be in its own ChristieNET interface (web browser) at the PC. Likewise, you can make up to five separate web locations to a single *Cine-IPM 2K*.

The default login provides access to security settings, where you can define other users with the same or fewer rights. Use “unlimited” rights for most applications. For all logins, the *Service* menu is still protected with its own password.

*NOTES: 1) Any proxy server settings that interfere with this type of link should be disabled for using ChristieNET. Disable through Internet Explorer's < Tools> <Internet Options> <Connections> <LAN Settings>. 2) Your PC must be Java-enabled to v1.4.2 or higher to run ChristieNET. 3) Certain controls provided through ChristieNET are non-functional for use with the **Cine-IPM 2K**.*

3.11 Using Multiple Cine-IPM 2Ks

This section describes how to work with multiple *Cine-IPM 2Ks* so that adjacent images are well-matched and have edges blended to form a seamless non-cinema display. References to “projector” in this section assume a *Cine-IPM 2K* is connected.

*NOTES: 1) Connection of multiple units is described in 2.6, **Linking Multiple Cine-IPM 2Ks**. For communications, see also 3.6, **Adjusting System Parameters and Advanced Controls**. 2) Assumes that each *Cine-IPM 2K* is connected to a CP2000.*

Matching Colors In Multiple Screens

▶ In a multiple-image wall, you will likely want to precisely match the hue and intensity of colors from image-to-image so that your full wall is as uniform as possible. This matching is typically done in conjunction with brightness uniformity and edge blending.

Preliminary Calibration

As a final part of the manufacturing process, all primary colors in the *Cine-IPM 2K* are precisely set to pre-established values to help ensure that overall color performance from your display device is optimized and is as accurate as possible (refer back to Figure 3.20). Upon installation at a site, however, lighting and other environmental factors may slightly change how these colors appear on each screen. While the change is negligible in most cases, you may prefer to recover the originally intended color performance before trying to match colors from several *CP2000s*.

The recommended first step in achieving such consistency is to use a color meter to measure the native primary colors—red, green, blue, and white—as they appear at the screen and record these as *Color Primary Settings* in the *Service* menu (password-protected) for each *Cine-IPM 2K*. On the basis of these new values, which are stored in memory, each unit will then automatically calculate any necessary corrections to reproduce the original factory-set colors under the current environmental conditions. This essentially calibrates the *Cine-IPM 2K* to its surroundings, compensating for factors such as screen type, lamp and/or ambient lighting that can alter the final color characteristics on-screen, and will improve color accuracy and consistency in a group of projectors. It ensures a good starting point for further customizing and matching.

To return to the factory-set color primaries, such as when the equipment is moved to different site, you must access the *Service* menu (password-protected). Select the *Reset to Factory Defaults?* option in the *Color Primaries* submenu. Then repeat the calibration process describe above, if desired, and continue with matching of colors.

Color Adjustment Procedure

NOTE: May interact with and affect other color adjustments available in the CP2000.

Once the *Color Primary Settings* are calibrated for the site (see above), use the *Color Adjustments by X,Y* or *Color Saturation* menu to further refine each *Cine-IPM 2K's* fundamental colors so that each color appears the same from one display to another. Once matched, you will have created a single new shared range of colors or “color gamut” that all of your projectors can produce. This palette—named User 1, 2, 3 or 4—can be applied or disabled for a non-cinema source at any time throughout a bank of adjacent displays, simplifying both the setup and maintenance of a “seamless” wall.

1. Set up and optimize all *Cine-IPM 2K* settings. You can ignore color temperature, since you will be redefining color performance in this procedure, but do optimize each unit in every other aspect. Closely align all screen edges.
2. Assign projector numbers to make communications easier.
3. Use the same lamp mode for all projectors, and do the following:
 - ❑ Set *Select Color Adjustment* to “Max Drives”
 - ❑ Display a full white test pattern
 - ❑ Adjust lamp power until adjacent white fields appear the same brightness.
4. Display the *Color Adjustments by X,Y* menus for all projectors. Each menu shows the x/y coordinates defining the “Max Drives” color gamut for the *Cine-IPM 2K* connected to this projector. Jot down the values shown in one (any) of the displays. See Figure 3.28. Or use the “Copy From” function to copy them into a “User” gamut in one *Cine-IPM 2K*.

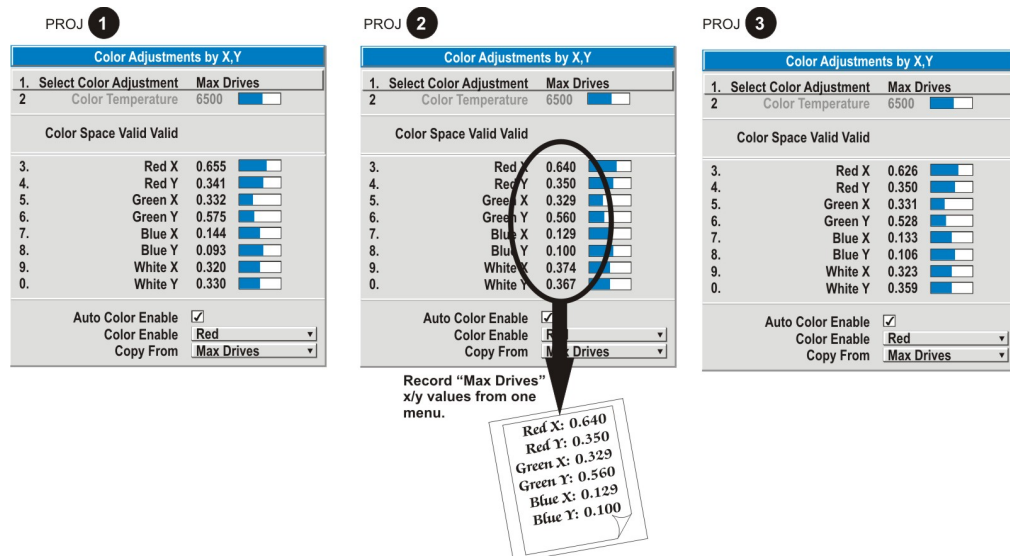

Figure 3.28. Jot Down a Set of “Max Drives” X/Y Values

5. In each projector, select a “User” color adjustment (1-4) to enable *Color Adjustments by X,Y* changes. Then enter your recorded x/y values into each menu (Figure 3.29).

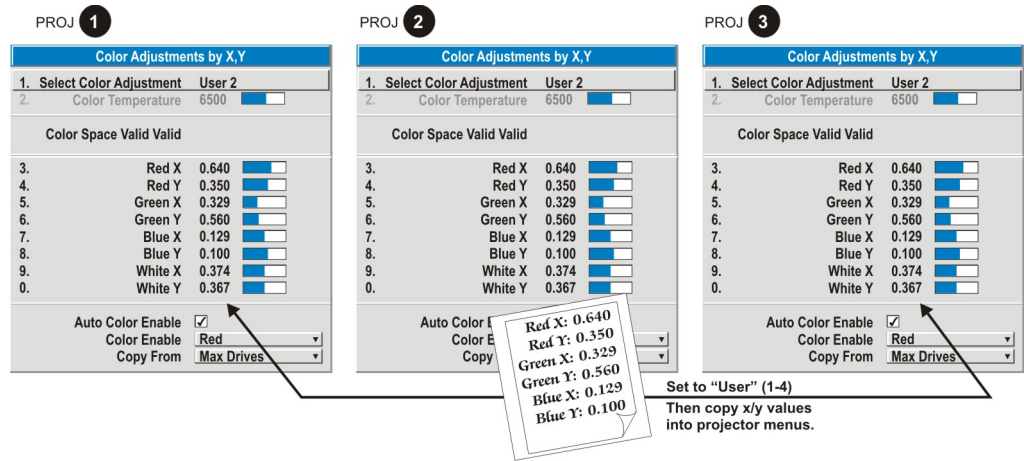
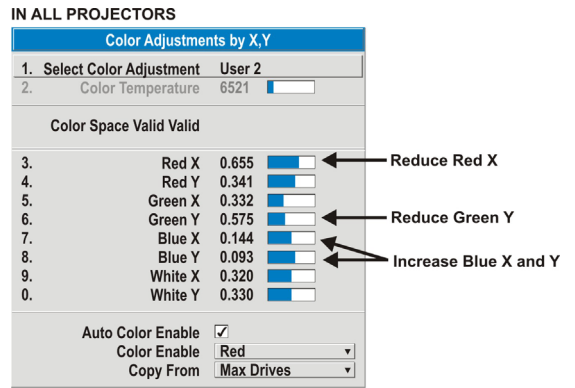

Figure 3.29. Copy X/Y Values into All Projectors

6. In each projector, judge by eye and adjust x/y coordinates slightly in the following manner:

- ❑ To match reds, decrease “Red X” until full field red screens match.
- ❑ To match greens, decrease “Green Y” until full field green screens match.
- ❑ To match blues, increase both “Blue X” and “Blue Y” until full field blue screens match.



NOTE: For speed, enable the “Auto Color Enable” checkbox.

Each color coordinate you select will then automatically trigger a full field display of the corresponding color.

These coordinate adjustments move the three color points closer together (refer back to the chromaticity chart shown in Figure 3.20) to establish a “shared” gamut attainable by all projectors in your group. Adjust only as necessary to ensure that the resulting color palette is as large as possible. When done, you may need to adjust lamp power slightly.

7. All screens should now be color-matched. Apply this new “User” gamut to a *Cine-IPM 2K* source at any time by selecting it in the “Select Color Adjustment” list accessed in the *Advanced Image Settings* menu.

Using the Color Saturation Menu for Color Matching

You may prefer to use the *Color Saturation* menu to match colors across multiple screens. In the three *Color Adjustment* submenus (Red, Green, Blue—see right), set all main values to 100 and the secondary values to 0. Then judge by eye and adjust the slidebars as needed. Note that adjustments here define new x/y coordinates in the *Color Adjustments by X,Y* menu.

Red Color Adjustment

1. Select Color Adjustment User 1

2. Color Temperature 6500

By x,y Equivalent x = 0.641 y = 0.406

3. Red Part of Red 100

4. Green Part of Red 288

5. Blue Part of Red -131

Green Color Adjustment

1. Select Color Adjustment User 1

2. Color Temperature 6500

By x,y Equivalent x = 0.335 y = 0.667

3. Red Part of Red 100

4. Green Part of Red 288

5. Blue Part of Red -131

Blue Color Adjustment

1. Select Color Adjustment User 1

2. Color Temperature 6500

By x,y Equivalent x = 0.180 y = 0.130

3. Red Part of Red 100

4. Green Part of Red 200

5. Blue Part of Red 800

6. Next Color

7. Copy From Max. Drives

Set tp 100
Judge by eye and
adjust all as needed.

Set tp 100
Judge by eye and
adjust all as needed.

Set tp 100
Judge by eye and
adjust all as needed.

Figure 3.30. Color Matching Using Color Saturation Menu

Achieving Brightness Uniformity

WHAT IS BRIGHTNESS UNIFORMITY? *Brightness Uniformity* can create an exceptionally smooth screen in which:

- no area of the screen appears more red, green or blue than another
- no area of the screen appears brighter than another
- color and light output from one screen closely matches adjacent screens

Brightness Uniformity controls are most often used for tiled images in a display wall, creating a uniform color “cast” and light output for each image and for the entire wall. However, because the *Cine-IPM 2K* cannot control lamp power, lamp adjustments from image-to-image must done on the display device itself (*CP2000*) rather through *Cine-IPM 2K* software.

Before You Begin

Read through the entire procedure before attempting to adjust Brightness Uniformity controls, and keep in mind the following checklist of prerequisites and guidelines:

- ❑ **ADJUST COLORS FIRST**—Always adjust the primary colors as described in the “*Matching Colors in Multiple Screens*” procedure (above) before attempting to work with Brightness Uniformity. This ensures that primary colors, color temperature, and maximized light output are all well-matched from one screen to another. These matches are needed before you can achieve good Brightness Uniformity results.
- ❑ **SET LAMP POWER**—In your *CP2000s*, make sure each “Lamp Power” setting is as high as possible for your application while still maintaining a good overall match of light output from screen-to-screen. By nature, achieving a

uniform brightness will require a slightly reduced *overall* brightness—this reduction will help ensure that you have enough range of adjustment when examining brightness variables more closely from screen-to-screen, and will help prevent premature “maxing out” when trying to match to a certain color, zone or adjacent screen.

- ❑ **USE A “USER” COLOR GAMUT (ADJUSTMENT)**—Always adjust Brightness Uniformity for a *User* color gamut defined when you matched primary colors, and continue to use it for all non-cinema sources displayed on the wall. Your other color palettes will not necessarily be matched from screen-to-screen.
- ❑ **WHITE UNIFORMITY SLIDEBARS**—White Uniformity slider values may not reduce to “0”. Each slider adjusts overall light output in a specific screen zone, but the value shown represents the current setting for *green* in this zone. When other “hidden” values (red or blue) are lower than green, during adjustment in the White Uniformity menu their values will reach “0” first, causing the slider to stop earlier than expected.
- ❑ **JUDGE BY EYE OR USE A METER**—Good brightness uniformity can be achieved with either method.

Step 1: General Setup

- 1a) Adjust primary colors (see *Matching Colors in Multiple Screens*) to ensure matched overall color temperatures and light output between screens.



Double-check that all WHITES and LIGHT OUTPUT are well-matched.

- 1b) Enable the *Brightness Uniformity* checkbox. This will enable access to the uniformity controls and will apply the settings to your image.

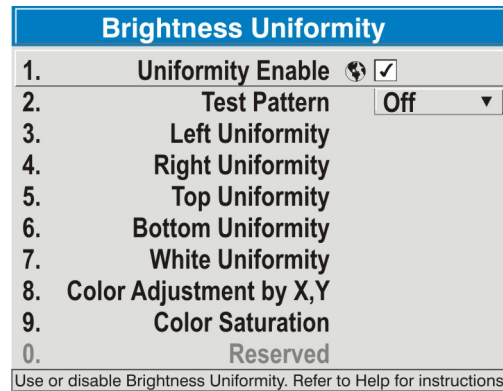

- 1c) Select the 13 Point test pattern for display. This pattern provides 9 screen “zones” with 13 targets.

FOR BEST RESULTS: Rather than examining the CENTER of each zone when assessing Brightness Uniformity adjustments, focus on extreme EDGES as indicated in the illustration at right.

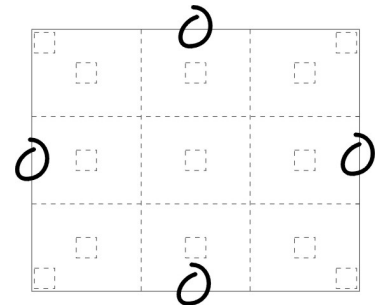

1d) In either *Color Adjustments* menu, select a “User” color. Then:

- *If you have created a “User 1” color gamut (recommended) for a well-matched wall, continue to Step 1e.*
- *If you prefer maximum brightness rather than a particular color temperature, select “Max Drives”.*



IMPORTANT
Do not change User 1 Color Adjustment
in color-matched applications!

1e) In the *White Uniformity* menu, set the “Overall” output level to **50.0** and all remaining slidebars to **0.0**. This decreases the light output *just enough* throughout the screen so that any color level can then be *increased* later as necessary for matching light output from zone-to-zone. Do not exceed **50.0** for “Overall”—

White Uniformity			
1.	Left Side	0.0	<input type="text"/>
2.	Right Side	0.0	<input type="text"/>
3.	Top Edge	0.0	<input type="text"/>
4.	Bottom Edge	0.0	<input type="text"/>
5.	Top Left Corner	0.0	<input type="text"/>
6.	Top Right Corner	0.0	<input type="text"/>
7.	Bottom Left Corner	0.0	<input type="text"/>
8.	Bottom Right Corner	0.0	<input type="text"/>
9.	Overall	50.0	<input type="text"/> ← Set to 50.0

Use or disable Edge Blending. Refer to Help and Manual.

a higher level will likely interfere with achieving brightness uniformity and is not recommended. *NOTE: The default setting for “Overall” White Uniformity is 50.2, which is also acceptable.*

Ensure that overall light output remains well-matched from one screen center to the next. Where necessary, use the TPC to increase or decrease lamp power slightly to recover center matches.

Step 2: Adjust Color (level of red/green/blue) in 8 Zones

*NOTES: 1) At this point, ignore the **brightness** of individual zones. 2) Always ignore menu colors.*

- 2a) On each screen, compare the color temperatures in the 8 target zones (4 edges and 4 corners) to that of the color temperature of the center. Compare using a *white* field only, and take note of any areas that do not match the center. Also decide if any screen exhibits a more obvious color shift than other screens—begin with this screen in Step 2b.
- 2b) Return to the *Brightness Uniformity* menu. Beginning with the screen that exhibits the most obvious color shift(s), for each edge that exhibits a noticeably different color temperature from the center, select the corresponding *Uniformity* adjustment menu—*Left, Right, Top* or *Bottom*. For example, if any part of the left side is too blue, too red or too green, go to the *Left Uniformity* menu and adjust the colors (i.e., change their light output) until all portions of the left side closely match the center color temperature. Adjust an edge first (focusing on its centerpoint), then adjust its corners. See Figure 3.31.

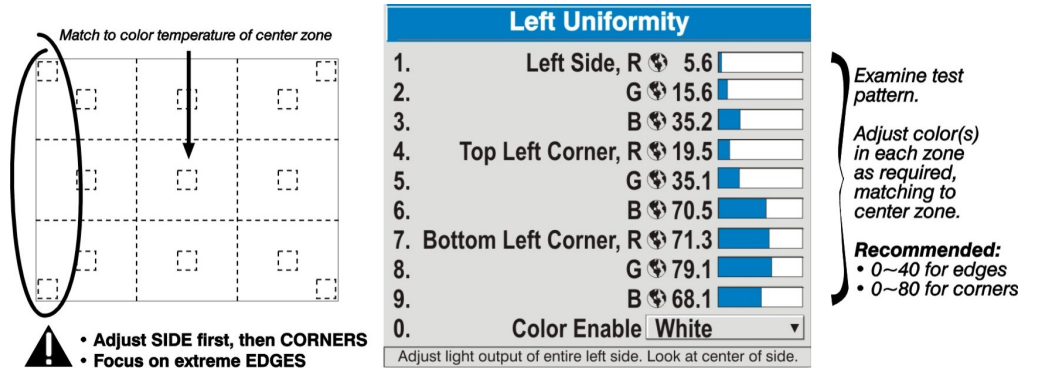

Figure 3.31. Match Zones to Center Color Temperature

Repeat the color adjustment of sides and corners for each edge of the screen that does not yet match the center (note that each corner is adjustable in either of its two adjacent “side” menus). When done, all areas of a given screen should match. Repeat Steps 2a & 2b for all remaining screens.

Step 3: Adjust Light Output in 8 Zones

3a) For each screen, compare the light output of each *edge* and *corner* to that of the *center*. If any of the areas differ, use the *White Uniformity* menu to match edges and corners to the center as described below (see Figure 3.32). Begin with the screen exhibiting the most obvious variations in light output.

- Adjust **edge** *White Uniformity* first—note that each edge adjustment also affects the rest of the screen slightly. Keep all edges just slightly *lower* than the center light output rather than matching light output precisely. Otherwise, it may not be possible to brighten the corners (typically the dimmest areas of the screen) enough. I.e., the best uniformity is a compromise between the brightest and darkest areas of the screen.
- Adjust **corner** *White Uniformity* last—each corner adjustment affects only this quadrant.
- Repeat for each screen.

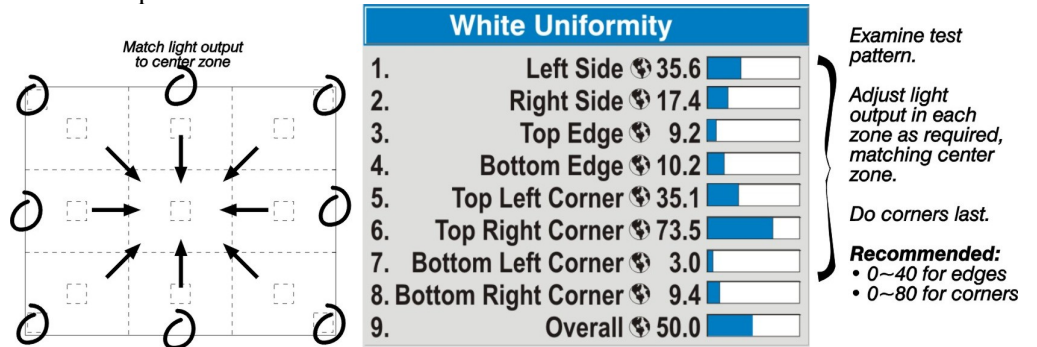

Figure 3.32. Match Zones to Center Light Output

Step 4: Readjust Color Temperature (level of red/green/blue) in 8 Zones

4a) Return to Steps 2a & 2b and, if necessary, fine tune the zones so that they all still exhibit a single color temperature.

Canceling Brightness Uniformity

If you do not want to use or apply Brightness Uniformity settings, delete the checkmark from the “Uniformity Enable” checkbox at the top of the *Brightness Uniformity* menu.

Edge Blending ► Christie *Edge Blending* is an innovative set of software functions that can quickly and easily blend the edges of multiple adjacent full screen images to create a single seamless larger image.

What is a Blend?

In simple terms, a blend appears as a gradient strip along an edge of a projected image. It is darkest along the extreme edge of the image, and lightens nearer to the rest of the image (see right). This area runs along the edge of the projector’s internal DMDs (display area); it cannot be located on interior pixels.

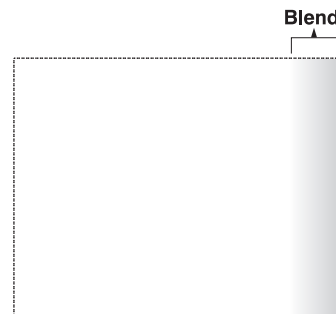

Figure 3.33

How Are Blends Used?

In multiple-projector walls, complementary blends between neighboring images can compensate for the extra “brightness” or intensity where these edges overlap. By controlling blend width and other properties, you can achieve uniformity across the group of images. Visible overlaps will disappear as illustrated below:

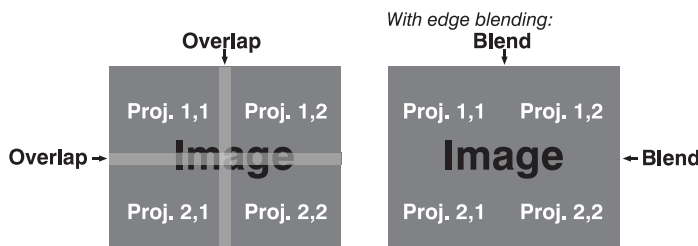
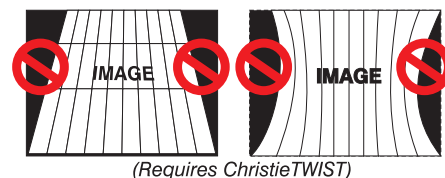

Figure 3.34. Edge Blending Concept

For best results, use the same display device (such as a *CP2000*) throughout your display wall. In addition, avoid high-gain screens whenever possible—the optical performance of such screens demands minimal image offset, thus projectors must be located very close to one another. Note too that the requisite tiling of the image—with data repeated along internal edges that will overlap—must be correctly done by your source.

Flat Blends vs. Warped Blends

FLAT BLENDS: It is important to remember that the *Cine-IPM 2K*’s standard edge blending controls affect the *outer edges* of the *CP2000*’s display panel, and that each blend is consistent along its length (refer back to Figure 3.33). The standard *Edge Blending* menu controls can blend multiple *flat* full-panel displays if they have no keystoneing or optional warping applied.



WARPED BLENDS: When using the optional *ChristieTWIST* module for warping images on to *curved* screens, work with its separate *ChristieTWIST* PC application to create more specialized blends required. Such a blend can vary along its length to compensate for curves. Once downloaded to the projector, simply apply the desired custom “user” blend by selecting it in the *Blending Enable* pull-down list.

Edge blending software controls are located in the 2-page *Edge Blending* submenu—access via *Configuration* menu, then go to the *Geometry and Color* menu and select *Edge Blending*. The *More* option opens the second page of the *Edge Blending* submenu.

Main Functions

Use edge blending controls to set the precise *width*, *shape* and *midpoint* you need to blend overlapping edges together smoothly.

- **Blend Width** determines how much area is used for blending along an overlapping edge. Sliderbar values represent the number of 8-pixel steps used for the blend. For example, a setting of “3” creates a blended edge 24 pixels wide. A setting of “0” signifies no blending. For best results in most applications, use a blend width of 16-48 steps (128-384 pixels).

Ranges: 0-80 horizontal, 0-60 vertical.

- **Blend Shape** determines the rate of roll-off across the blend width, i.e. how quickly the white levels across the blend change from light and dark. Increasing the *Blend Shape* setting accelerates the rate of change at both extremes so that *less* of the region appears mid-gray (see Figure 3.35). Decreasing the *Blend Shape* setting slows the rate of change so that *more* of the region appears mid-gray. For most applications, this subtle control is best left close to 50.

(NOTE: Simulation shown darker for printed page)

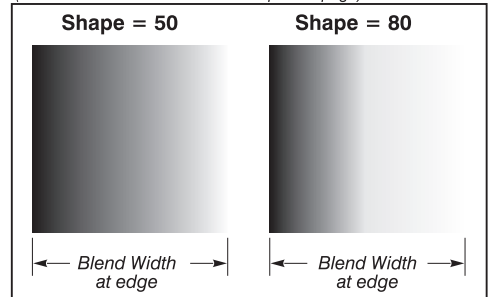

Figure 3.35. “Shape” Examples

- **Blend Midpoint** determines the white level at the blend midpoint (the point equidistant between the beginning and end of the blend). Increasing the *Blend Midpoint* setting creates a blend that appears brighter than the rest of the image. Decreasing the *Blend Midpoint* setting creates a blend that is darker than the rest of the image. A setting of 50 means the midpoint is approximately 50% black—for best results in most applications, keep fairly close to this default. See Figure 3.36

(NOTE: Simulation shown darker for printed page)

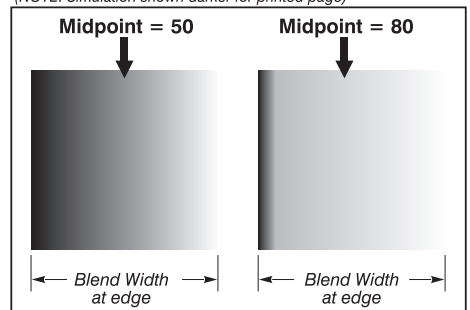
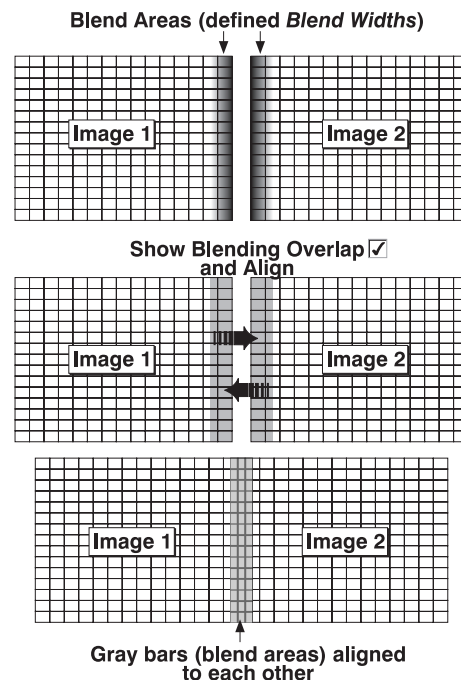

Figure 3.36. “Midpoint” Examples

- Show Blending Overlap** turns your defined blend width area to solid gray so that two adjacent images can be seamlessly aligned simply by overlapping their gray bars, if needed. Toggle the *Show Blending Overlap* off to reactivate the blend effect. *NOTE: Show Blending Overlap appears as **Reserved** when ChristieTWIST is installed.*



Other Functions

For convenience, the *Edge Blending* submenu also includes related options for enabling a specific color and/or test pattern, or for working with colors or the lamp. Such functions duplicate those provided elsewhere in the *Cine-IPM 2K* menu system.

Edge Blending Procedure

BEFORE YOU BEGIN: Make sure your source hardware and/or software can supply a *tiled* image for the number of projectors in use, and that the tiling includes overlapping data of approximately 12.5-25% along shared edges (see Figure 3.37). Tiling not a *Cine-IPM 2K* or *CP2000* feature.

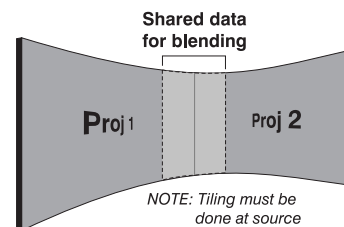

Figure 3.37. Tiling Example

Physically align the projectors and images from your intended external source, then match colors and Brightness Uniformity.

IMPORTANT

For a shared edge, all *Blend* procedures and settings should be identical on BOTH projectors.

1. Start with 2 projectors. Display full white field test pattern from both.
2. In the *Edge Blending* submenu, enable the top checkbox to activate all controls.

NOTE: If the optional ChristieTWIST module is installed, a pull-down list replaces this

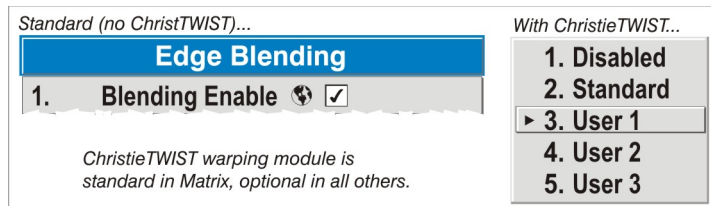

*check*box (see right). Select the desired user-defined blend created for your current warp; no further blending at the projector is required. Or, to simply edge blending a non-warped flat image, select “Standard” and continue with Step 3.

3. SET STARTING POINTS FOR ADJUSTMENT:

- Set all blend widths to 0.
- Go to “More” and set everything in the *Edge Blending (2)* menu to 50.

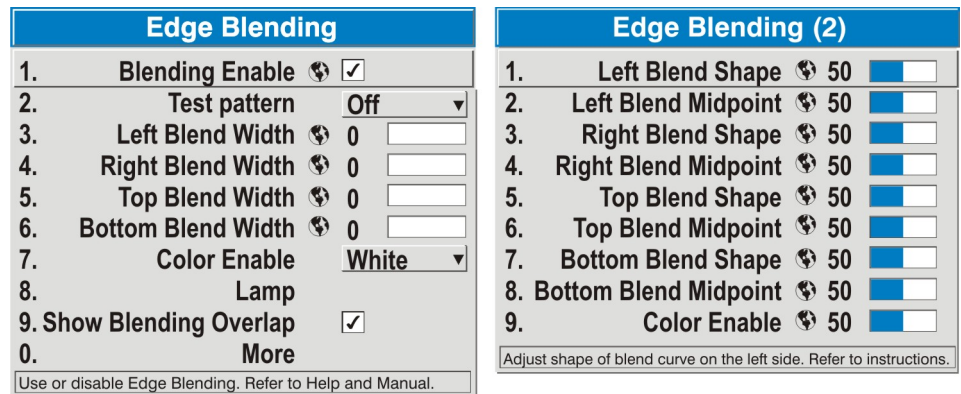

Figure 3.38. Set Starting Points for Each Projector

4. **SET BLEND WIDTH:** On one projector, increase the *Blend Width* for an overlapping edge (for example, if the projector’s image is on left, its right edge overlaps the adjacent image—adjust *Right Blend Width*). Use the same setting on the second projector for this shared edge.
5. Re-adjust width (both projectors) until the overly bright band at the midpoint of the overlapping blends disappears or *just* changes to very light gray. For the shared edge, use the same *Blend Width* setting on each projector. If the “best blend” appears to be between two settings, choose the wider setting for both projectors.
6. **CHECK BLEND:** If the blended region appears too dark or light in relation to the rest of the image:
 - Increase *Blend Midpoint* in both projectors to “lighten” the overall blend, decrease to “darken” the overall blend.
 - Adjust *Blend Shape* in both projectors to fine-tune change the amount of mid-gray intensity (as opposed to black/white) in the blend.
7. Repeat with remaining projectors / overlaps.
8. Check completed display wall with the desired external signal.
9. Adjust mechanical alignment if necessary to maintain perfect pixel-on-pixel alignment over time.

In applications where you are projecting only light images, the *Blend Width* may be slightly higher—set according to how much overlap you have between images.

3.12 Error Conditions

Occasionally the *Cine-IPM 2K* will encounter an error condition that can interrupt normal operation. Such a condition can be caused by a simple invalid keypad entry, an input signal error (most common), or a system error. The manner in which users are to be notified of error conditions is set in the *Menu Preferences* menu:

- To see error messages displayed on-screen, select the “**Screen**” option
- To be notified via a serial communication only, select the “**RS232**” option.
- To receive both types of notifications, select “**All**”.
- To disable error messages (except for “invalid user key entry”, which can’t be hidden), select “**Off**”.

Note that text-based status/error messages also appear in the LCD Status Display window on the *Cine-IPM 2K* front panel.

User Errors ► **Invalid User Entry**

A keypad entry not recognized by the *Cine-IPM 2K* triggers a short on-screen error message identifying the problem. For example, if you specify a channel number that is not available, the message “*Invalid Channel*” will appear. Or if you try to enter the wrong password, you’ll see “*Invalid Password*”. Press ▲ or ▼ to clear the message and try again.

*NOTE: On-screen display of “Invalid User Entry” messages cannot be disabled, even if **Display Error Messages** has been set to “Off”.*

- Input Signal Errors** ► An input signal error message occurs if you are in presentation level (i.e., there are no menus present) and have selected an input on which the *Cine-IPM 2K* detects a problem. While menus remain operational and any key press will temporarily remove any displayed error message, you must resolve the signal problem in order to permanently eliminate the message.

No Signal

The message “*No signal*” occurs when there is no source signal detected at the selected input—both HSYNC and VSYNC are inactive and the screen background is black. Connect or correct the signal, or try another input.

Bad Sync

The message “*Bad Sync*” occurs when HSYNC or VSYNC are active but the signal cannot be displayed. Such a condition occurs when only one of the two sync signals is present, or when either sync signal is unstable or of the wrong frequency. Correct the signal or select another input.

Other Signal Error Messages

In addition to the common “*Bad Sync*” and “*No Signal*” errors, you may encounter a signal error message indicating that HSYNC and/or VSYNC are either too fast or too slow. When such a message appears, check the frequencies shown in the *Status* menu. If they are correct, then the signal is not recognized by the *Cine-IPM 2K*. On some PCs you may be able to change the settings to generate a compatible signal. If the frequencies shown in the *Status* menu are incorrect, check the cabling to see where the problem might originate.

- System Warnings & Errors** ► When the *Cine-IPM 2K* encounters a system malfunction, either a *System Warning* message or a *System Error* message may appear. Both types of messages are accompanied by a related text message in the LCD Status Display window. A system malfunction can be cleared from presentation level, but may indicate the need for service by a qualified service technician.

*NOTE: System messages appear on-screen only if **Display Error Messages** has been set to “Screen” or “All”.*

System Warnings

A system *warning* indicates that a system malfunction has been detected (*Status Display*, below). A system warning message replaces any input signal message and disappears when the input signal status changes. While the projector will remain

operational, the message indicates the presence of a potentially serious problem that should be reported to the manufacturer. You can remove the message, but for best results you should reset the projector—power the projector down and up again with the POWER key.

System Errors

A system *error* message indicates that a serious malfunction has been detected and must be reported to the manufacturer as soon as possible (see *Status LED Codes*, below). The projector will no longer operate and must be reset—power the projector down and up again with the POWER key.

Status Display

If the Status Display window on the front of the *Cine-IPM 2K* shows one of the following messages, you have encountered a likely system error requiring the attention of a qualified service technician (see *System Warnings* and *System Errors*, above). Acknowledge and clear the error from presentation level, or try resetting the *Cine-IPM 2K 2* by powering it off and on again, cooling when necessary. Consult Table 3.4 and contact your dealer if the problem persists.

Table 3.4. System Error Codes

Code	Description
GENERAL	
12	Software error. Power off/on. If persists, contact dealer/factory.
13	CRC error in flash ROM. Download new software.
14	Engineering-only programming is complete. Call Christie, replace TIPM.
15	Attempting to download s/w code without being in boot mode
16	Invalid interrupt. Power off/on. If persists, contact dealer/factory.
17	User has forced system to stay in boot mode
18	Attempting to program boot mode without jumper
SENSORS for COOLING	
4C	Projector has shut down due to critical error
FAN	
51	Fan has failed in <i>Cine-IPM 2K</i>
10-bit IMAGE PROCESSOR (TIPM)	
60	Boot code CRC failed
61	Unable to program the DigMux PLD
62	Unable to program the Control PLD
63	Unable to program the Bubks PLD
64	Unrecognized ROM type
65	Write to flash ROM failed
66	General TIPM failure
67	Downloaded code will not fit into ROMs
68	Communication error with scaler on TIPM
DDOM and EEPROM	
70	Unable to access EEPROM on DDOM
71	EEPROM on DDOM has been reinitialized
BACKPLANE OR OPTIONAL MODULES	
A0	Unable to program the optional interface module
A1	Unable to power the optional interface module
A2	Unable to program the Backplane
A3	Unable to program the Warp Module option (<i>ChristieTWIST</i>)

If necessary, try resetting your system by powering it off and on again (cooling if necessary). For detailed information, monitor the RS232 IN port. Contact dealer/factory if error persists. Only codes listed should appear in the Cine-IPM 2K window.

Maintenance

4.1 Warnings and Guidelines

This product is designed for safe and reliable operation. However successful operation is not assured by design alone; installers, service technicians, trained operators and all other users must maintain a safe environment ***at all times***. Please read through and understand all warnings and precautions before attempting to operate the *Cine-IPM 2K*.

Labels and Markings ► Observe and follow any warnings and instructions marked on the *Cine-IPM 2K*.



The exclamation point within the equilateral triangle indicates related operating/maintenance instructions in the documentation accompanying the projector.



The lightning flash and arrowhead symbol within the equilateral triangle indicates the presence of non-insulated "dangerous voltage" that may be of sufficient magnitude to constitute a risk of electric shock.

General Precautions ► Always follow the precautions and warnings provided with your display device—for example, consult *Section 4* in the *CP2000 User's Manual* for all warnings pertaining to the use of that projector. Be aware of the following general precautions in all installations:



WARNING

Position all cables where they cannot contact hot surfaces or be pulled or tripped over.

The *Cine-IPM 2K* must be installed in an environment, which meets the operating range specifications in *Section 6, Specifications*.



WARNING

Opening or removing a *Cine-IPM 2K* cover requires a qualified service technician.

AC / Power Precautions ►



WARNING

Do not attempt operation if the AC supply is not within the specified voltage range.

Do not allow anything to rest on the power cords. Locate the projector where cords cannot be abused by persons walking on it or objects rolling over it. Never operate the *Cine-IPM 2K* if the power cable appears damaged in any way.

Do not overload power outlets and extension cords as this can result in fire or shock hazards.

Note that qualified service technicians only are permitted to open an enclosure on the product, and only if AC has been fully disconnected.

4.2 Maintaining Proper Cooling

The *Cine-IPM 2K* electronic components rely on a single cooling fan to reduce internal operating temperatures. This cooling is critical in preventing sudden failure, and helps to ensure reliable operation of all components over time.

- Ventilation** ► Mesh side grills provide ventilation, both for intake and exhaust. Never block or cover these openings. Do not install the product near a radiator or heat register, or within a small enclosure. The *CP2000* pedestal cavity provides adequate space for airflow.
- Air Filter** ► There is no air filter in the *Cine-IPM 2K*.

Troubleshooting

If the *Cine-IPM 2K* does not appear to be operating properly, note the symptoms present and use the following guide to assist you. If you cannot resolve the problems yourself, contact your dealer for assistance.

*NOTE: A **qualified service technician** is required when opening the *Cine-IPM 2K* to diagnose any “probable cause”*

5.1 Power

- Cine-IPM 2K Will Not Start** ►
1. Check Status Display window. If the window is dark (with no message), make sure the *Cine-IPM 2K* front power switch is on—the window should then show “power off”.
 2. If the window is still dark, make sure the *Cine-IPM 2K* is plugged into AC.
 3. If plugged into the AC convenience outlet inside the *CP2000* pedestal, make sure the corresponding CP2000 breaker labeled “Internal” is ON. This breaker is located on the side of the operator’s side of the pedestal.
 4. Make sure the keypad is connected or has batteries.

5.2 Ethernet

1. Make sure the Ethernet settings are valid for your site—all network devices should have the *same* subnet mask and *unique* IP addresses.
2. Make sure the *Cine-IPM 2K* is connected to the network before changing its IP address.
3. If you still have trouble establishing communications with a *Cine-IPM 2K* added to an existing Ethernet network, the *Cine-IPM 2K*’s IP address likely conflicts with another address already in use. Contact your network administrator.
4. Use the front Ethernet port only, as the rear Ethernet port is not currently supported.

5.3 Displays

- Symptom** ► **Image does not fill the screen**
- CAUSE / REMEDY:**
1. Check the *Cine-IPM 2K* output resolution setting to see if it matches the resolution of your display device. For example, specify a 2048 x 1080 output resolution to fill the *CP2000* native display area.
- Symptom** ► **Cannot Select Inputs Using the TPC**
- CAUSE / REMEDY:**
1. Make sure the *Cine-IPM 2K* is connected to RS232-B port on the projector.

- Symptom** ► **Image appears “squeezed” or vertically stretched into center of screen**
CAUSE / REMEDY:
1. Check your Resizing selection. Use the *Cine-IPM 2K* “Anamorphic” resizing preset for a vertically squeezed image, then enlarge as necessary using the *Cine-IPM 2K* “Size” control.
 2. For best results from a DVD player, and to optimize proper sizing features, it is recommended to set the DVD output as 16:9 widescreen (as opposed to 4:3 or 4:3 pan scan).
 3. The anamorphic lens (optional) may be needed for this source.
- Symptom** ► **System is powered up but there’s no display...**
CAUSE / REMEDY:
1. Was a lens cover accidentally left on? Remove lens cover.
 2. At the TPC, make sure the *CP2000* shutter is OPEN (the *Cine-IPM 2K* keypad’s shutter button is not functional).
 3. Is the lamp ignited? Check for interlock problems such as an open lamp door.
 4. Make sure there is not a *Cine-IPM 2K* full black test pattern selected for display—press TEST on the remote to access test patterns, then cycle patterns with ◀ ▶ keys.
 5. Is the correct input selected? On the TPC, ensure the correct DVI input is selected.
 6. Make sure DVI output from *Cine-IPM 2K* is connected properly to the CP2000.
 7. The wrong output resolution may be selected in the device.
 8. V1.1 software cannot process HDCP source material and will display a full black field—make sure your incoming DVI signal is not digitally encrypted.
 9. Is the source connected properly? Check the cable connections and make sure the correct source is selected.
- Symptom** ► **The display is jittery or unstable...**
CAUSE / REMEDY:
1. If the display is jittery or blinking erratically, ensure that the source is properly connected and of adequate quality for detection. With a poor quality or improperly connected source, the projector will repeatedly attempt to display an image, however briefly.
 2. The horizontal or vertical scan frequency of the input signal may be out of range for the projector. Refer to *Section 6, Specifications* for scan frequency ranges.
 3. The sync signal may be inadequate. Correct the source problem.
 4. The wrong output resolution may be selected in the device.
- Symptom** ► **The display appears unusually dim or faint...**
CAUSE / REMEDY:
1. Brightness and/or contrast may be set very low.
 2. The source may be double terminated. Ensure the source is terminated only once.
 3. The source (if non-video) may need a different sync tip clamp location.
 4. The lamp may not be properly aligned in the projector. Use the *CP2000* LampLOC adjustment.
- Symptom** ► **The upper portion of the display is waving, tearing or jittering...**
CAUSE / REMEDY:
1. This can sometimes occur with video or VCR sources. Check your source.

- Symptom** ► **Portions of the display are cut off or wrap to the opposite edge...**
CAUSE / REMEDY: 1. Resizing and/or blanking may need adjustment.
- Symptom** ► **The display appears compressed (vertically stretched)...**
CAUSE / REMEDY: 1. The frequency of the pixel sampling clock is incorrect for the current source.
 2. Resizing, vertical stretch and positioning options may be improperly adjusted for the incoming source signal.
 3. You may need an anamorphic lens for sources that have been supplied in a re-sized and vertically stretched format.
- Symptom** ► **Data is cropped from edges**
CAUSE / REMEDY: 1. Check settings for Blanking.
 2. If incoming data is still missing from the image, reduce the image size to within the display area available in the projector.
 3. Make sure you are *not* using the cinema processing path on the *CP2000*.
 4. If the image is cropped Left/Right, you may be exceeding the current bandwidth limitations of the processing chip. Reduce the re-size settings or (if possible) reduce the incoming signal's vertical frame rate.
 5. If the image is cropped top/bottom, you may have exceeding the vertical frame rate limitations for the DVI port on the *CP2000*. If possible, reduce re-size setting to fit within the cropping area or reduce the vertical frame rate of the incoming signal on the *Cine-IPM 2K* input. Make sure you are *not* using the cinema processing path on the *CP2000*.
 6. Check the TPC setting to ensure source and screen are set to 2048 x 1080, or Auto Square pixels.
- Symptom** ► **Display quality appears to drift from good to bad, bad to good...**
CAUSE / REMEDY: 1. The source input signal may be of low quality.
 2. The H or V frequency of the input may have changed at the source end.
- Symptom** ► **The display has suddenly frozen...**
CAUSE / REMEDY: 1. If the screen blacks out inexplicably, it is possible that excessive voltage noise on the AC or ground input has interrupted the projector's ability to lock on to a signal. Power down the projector and/or *Cine-IPM 2k* and disconnect from AC. Then plug in again and power up as usual.
- Symptom** ► **Colors in the display are inaccurate...**
CAUSE / REMEDY: 1. The color, tint, color space, color temperature and/or other settings may require adjustment.
 2. Make sure to use the proper TPC settings—color space on the *CP2000* should be an RGB format, with gamma set to Gamma 2.6.
 3. Make sure you are using the proper channel for this source.
- Symptom** ► **The display is not rectangular...**
CAUSE / REMEDY: 1. Check leveling of the projector. Make sure that the lens surface and screen are as parallel to each other as possible.
 2. Ensure "Keystone" is set correctly.
 3. Is the vertical offset correct? Adjust as necessary using the vertical offset knob.

4. Make sure the aperture in the anamorphic lens (if present) is correctly oriented.

Symptom ► **The display is “noisy”...**

CAUSE / REMEDY:

1. Display adjustment at your input source may be required. Adjust pixel tracking, phase and filter. Noise is particularly common on YPbPr signals from a DVD player. (If using a PC source, adjust using a high-frequency test pattern with one pixel on/off throughout.)
2. The video input may not be terminated. Make sure the video input is terminated (75 Ω). If it is the last connection in a loop-through chain, the video input should be terminated at the *last* source input only.
3. The input signal and/or signal cables carrying the input signal may be of poor quality.
4. If the distance between the input source device and the projector is greater than 25 feet, signal amplification/conditioning may be required.
5. If the source is a VCR or off-air broadcast, detail may be set too high.
6. If 10-BIT DVI output is enabled, ensure the DVI harnesses are connected correctly. Select DVI 10 bit Twin-Link at the TPC.
7. For computer graphics, ensure that the video card on the computer/laptop can handle the chosen resolution and/or this is within the *Cine-IPM 2K* input bandwidth limit.
8. Some broadcast material can have a large amount of noise in its content. Try using the noise reduction feature on the *Cine-IPM 2K*.

Symptom ► **Noise or sparkling on video**

CAUSE / REMEDY:

1. Your DVI cables may be of poor quality or are too long. Use cables provided with the *Cine-IPM 2K*.

Symptom ► **Cannot display from DVI source**

CAUSE / REMEDY:

1. Your DVI source may be HDCP encrypted. The *Cine-IPM 2K* does not support this.

Symptom ► **Incorrect colors**

CAUSE / REMEDY:

1. Make sure to select “Unity RGB” color space at the TPC.

Symptom ► **Severe Color Distortion with 10-bit Twin-Link DVI**

CAUSE / REMEDY:

1. DVI cables are likely reversed.

Symptom ► **Optional input modules do not work**

CAUSE / REMEDY:

1. Ensure option cards are seated all the way in, flush with front of the *Cine-IPM 2K*.
2. Re-seat the option card.
3. Make sure either input 5 or input 6 is selected appropriately.

Specifications

NOTE: Due to continuing research, specifications are subject to change without notice.

6.1 Specifications

Outputs for Display ► Format

Available resolutions	2048 x 1080 (default)
NOTE: Assumes use with CP2000. Support may vary with other display devices.	1920 x 1080
	1400 x 1050
	1280 x 1024
	1280 x 720
	1024 x 768
Color Space	Progressive RGB
Bit-per-component	8 bits or 10 bits (selectable in s/w)

Colors and Gray Scale

Default color gamut	Maximum drive
Range of color temperature adjustment	3200K – 9300K
Displayable colors	1.1 billion
Gray scale resolution	10 bits each per RGB component

Gamma

Adjustable from 1.0 – 2.8 (default = 2.2 ± 0.4)

Inputs ►

Total number of available inputs 6 (4 supplied as standard)

Analog: RGB / YPbPr (5 BNCs at INPUT 1)

Scan format	Interlaced or Progressive
Signal types / color spaces	<ul style="list-style-type: none"> • RGB • YPbPr
Horizontal frequency range	15 – 120 kHz
Vertical frequency range □	23.97 – 150 Hz
Pixel clock rate	13 – 210 MHz
Active pixels per scan line (H)	640 – 2048
Active lines per field/ frame (V)	200 – 1536
A/D conversion resolution	10-bit
Input levels	
R,B,G,Y — with sync	1.0V _{p-p} ±2 dB (0.79V _{p-p} – 1.26V _{p-p})
R,G,B — without sync	0.7V _{p-p} ±2 dB (0.56V _{p-p} – 0.88V _{p-p})
Pb,Pr	0.7V _{p-p} ±2 dB (0.56V _{p-p} – 0.88V _{p-p})
DC offset	± 5V
Nominal impedance	75 Ω
Max. return loss (VSWR)	1.2:1 dB @ 200 MHz

□. Specifies **frame** rate for non-interlaced sources and **field** rate for interlaced sources. Input frequencies higher than the maximum panel refresh rate are displayed at a lower rate.

Analog: Video (INPUTS 3 and 4)

Signal formats	Composite (CVBS), S-Video (Y/C)
Connectors	BNC
• Composite Video (INPUT 3)	4-pin miniature DIN
• S-Video (INPUT 4)	NTSC, NTSC 4.43, PAL, PAL-M, PAL-N, PAL-60 & SECAM
Video standards	8-bit
A/D conversion resolution	
Input levels	
Composite	1.0 V _{p-p} ± 3dB (including sync tip)
S-Video, Luma (Y)	1.0 V _{p-p} ± 3dB (including sync tip)
S-Video, Chroma (C)	630 mV _{p-p} nominal (burst)
DC offset	± 2V
Nominal impedance	75 Ω
Maximum return loss (VSWR)	1.2:1 dB @ 6 MHz

Analog: Sync (INTERLACED OR PROGRESSIVE SCAN FORMAT)

Input levels (for composite or separate H & V)	0.5V _{p-p} – 4.0V _{p-p}
Impedance (for composite or separate H & V)	75 Ω
Sync type (for composite or separate H & V)	<ul style="list-style-type: none"> • Separate H and V • Bi-level or tri-level sync-on-green • Bi-level or tri-level composite • Serrations and/or Equalization pulses • MacroVision™ for std. & prog. video
Polarity (for composite or separate H & V)	Positive or negative
Maximum return loss (VSWR)	1.2:1 dB @ 200 MHz

DVI-I (INPUT 2)

Interface standard	DDWG DVI 1.0
Signal types / color spaces	<ul style="list-style-type: none"> • RGB (digital or analog) • YPbPr (analog) • YCbCr (digital) <i>not supported in v1.1</i>
Horizontal Frequency Range	15 – 120 kHz
Vertical Frequency Range	23.97 – 150 kHz
Pixel clock rate	25 – 165 MHz
Analog sync input impedance	1 kΩ
Maximum cable length	5 meters (16 ft.)
Supports EDID	

Does not support HDCP. For all other DVI specifications, see Analog: RGB / YPbPr on previous page.

Control ► Wired Remote (CONVERTED FROM IR REMOTE KEYPAD)

1 input (front)	• 3.5mm phono jack
Input levels	• High = 2.2 V – 5.6 V (or open)
	• Low = -0.6V – 0.9V @ 1mA
Voltage output	+5VDC ±5%
Current output	100 mA nominal, 250 mA max.
Cable length	25 ft.

Infrared (IR) Remote

Number of IR sensors	1 (front)
Wavelength of peak sensitivity	950 nm
Modulation (carrier) frequency	36 kHz (nominal)
Encoding method	bi-phase
Reception range *	100 ft.

* Assumes no fluorescent lighting interference.

Ethernet (FRONT PANEL ONLY)

Number of ports	1
Standard	100Base-TX
Connector type	RJ-45
Max. baud rate	115200

RS232 Serial Input

Number of connectors	2 (female= IN , male= OUT)
Connector type	9-pin subminiature D
Max. baud rate	115200

RS422 Serial Input

Number of connectors	1
Connector type	9-pin subminiature D
Max. baud rate	115200

GPIO Input

Number of I/O lines	7, each assignable as input or output
Connector type	9-pin subminiature D
Type of connection	Dry contact
Output sink current (<i>logic low</i>)	100 mA @ 1V
Maximum power output	+12VDC @ 200 mA (NOTE: <i>shared with 9-pin RS422 port</i>)

Power ▶
▲

Voltage range	100 – 240 VAC ±10%
Line frequency, nominal	50 – 60 Hz
AC input rating	15 A
Max. inrush current	38 A
Max. current consumption □	1 A (@ 100 VAC)
Max. power consumption □	100 W

Audible Noise ▶

48 dBA maximum

Safety ▶

- **UL 60950** and **CAN/CSA C22.2. No. 60950** (2000, 3rd edition, bi-national)
- **IEC 60950** (1999, 3rd edition)

EMC Emissions ▶

- **FCC CFR47, Part 15, Subpart B, Class A** — Unintentional Radiation
- **CISPR 22: 1997 / EN55022: 1998** — Radio disturbance characteristics, ITE

EMC Immunity ▶

- **CISPR 24 / EN55024:1998** (all parts of immunity characteristics for ITE)

Operating Environment ▶

Temperature	10°C to 35°C (50°F to 95°F)
Humidity (non-condensing)	20% to 80%
Altitude	0 – 3000 meters
Tilt, any angle	15° max.

Non-Operating Environment▶

Temperature	-25C to 65°C (-13°F to 149°F)
Humidity (non-condensing)	0% to 95%

SPECIFICATIONS

Weight & Size ▶

Weight	16 lb. (22 lb. w/package) 7.3 kg (10 kg w/package)
Standard Dimensions (W x L x H) <i>(without ears for rack mounting)</i>	17" x 12" x 5¼" (43.2 cm x 30.5 cm x 13.3 cm)
Rack-mount height	3RU

Standard Components ▶

Cine-IPM 2K with pre-installed ears for rack-mounting
Remote keypad
Keypad cable
Custom RS232 communication cable *(for use with CP2000 only)*
3-ft. DVI output cables (2)
10-ft. power cord
4 self-adhesive feet

Options ▶

KoRE Librarian Setup Software
Longer-distance DVI cables (copper and fiber-optic)
Remote IR Sensor
Christie *TWIST*™ (Warping Module)
Optional Input Modules — see Appendix E

Appendix A

Glossary

This appendix defines the specific terms used in this manual as they apply to this projector. Also included are other general terms commonly used in the projection industry as well as in the digital cinema projection industry.

- 3:2 Pulldown** ► A frame sequence used to map 24 fps film to 30 fps video (or 24/1.001 to 30/1.001 fps) in which every second film frame is represented by three video fields instead of two, the third being a repeat of the second. This leads to a set of ten video fields for each four film frames.
- Active Line Time** ► The time—inside one horizontal scan line—during which video data is present.
- Alternative Content** ► Non-cinema program material such as concerts, plays, sporting events, and potentially corporate training or conferencing, presented in theatres in addition to motion picture exhibition.
- Ambient Light Rejection** ► The ability of a screen to reflect ambient light (i.e., light within a room from a source other than the projector) in a direction away from the "line of best viewing". Curved screens usually have better ambient light reflection than do flat screens.
- Anamorphic** ► Having or requiring a linear distortion, generally in the horizontal direction. Anamorphic lenses can restore a 'scope' (CinemaScope) or 'flat' format film frame to the correct wide-screen appearance by increasing its horizontal proportion. The *Roadie 25K* uses a 1.25x scope anamorphic lens option only.
- ANSI** ► The American National Standards Institute is the organization that denotes the measurement standard for lamp brightness.
- Answer Print** ► A print made from the cut original (camera) negative with proposed final color timing and soundtracks, furnished by the printing lab to the producer for acceptance of image and sound before screenings and manufacturing begin. A check print is similar, but is made from the *internegative*. A blacktrack answer print has no soundtracks.
- Aspect Ratio** ► The ratio of the width of an image to its height, such as the 4:3 aspect ratio common in video output. Also expressed as decimal number, such as 1.77, 1.85 or 2.39. The larger the ratio or decimal, the wider and "less square" the image.
- Authoring** ► The process, tools, and working environment by which content elements and functions are compiled, formatted, coordinated, and tested for presentation on target systems. *Comment:* Authoring in the context of digital cinema does not necessarily result in inseparably married or muxed content components. Rather, reference is made to a virtual answer print, the elements of which may subsequently be subdivided or combined, encrypted in whole or part, and packaged in various ways

for distribution of the title, a version of the title, or an update for revision of the title in the field.

- Automation** ► A system used in a theatre projection booth that responds to cues, commands or relay switches and then controls various elements of presentation, such as:
- ❑ picture format and corresponding lens (flat or scope)
 - ❑ sound format and corresponding cinema processor settings
 - ❑ curtain movement and position
 - ❑ lighting level in the auditorium
 - ❑ non-sync play and fade in/out
 - ❑ digital cinema projector
- Auto Source** ► The ability of a projector to automatically recognize and lock synchronizing with the horizontal and vertical scan frequencies of an input signal for proper display.
- Bandwidth** ► The frequency range of a video amplifier.
- Baud Rate** ► The speed (bits-per-second) at which serial communications travel from their origin.
- Bit Depth** ► The total number of bits available to represent each pixel or color sample in a digital imaging system. Using linear binary coding, the total number of resolution steps available is equal to 2 raised to the power of the bit depth.
- Blanking Time** ► The time inside one scan line during which video is not generated. The blanking time of the input signal must be equal to or greater than the retrace time of the projector.
- Brightness** ► In cinema projection, brightness usually describes the amount of light emitted from a surface such as a screen. It is measured in footlamberts or candelas per square meter. For other types of projection, brightness is measured and expressed in lumens.
- Candela or Candle** ► Unit of measure for measuring intensity of light in certain types of projectors.
- Channel** ► A collection of measurements stored by the projector for a given input source, including frequencies, pulse width, polarity, syncs, channel number and location, user-adjustable display settings, etc. Use channels to switch between a variety of setups quickly, automatically recalling previously defined display parameters.
- Channel List** ► A list/menu of previously-defined channels (setups) available in projector memory.
- Channel Number** ► A number that uniquely identifies a specific channel retained in projector memory. The projector can store up to 50 channels for use with a variety of sources.
- Checkbox** ► A menu item that indicates whether an option is currently in effect (checked) or not (unchecked).
- Chrominance** ► The signal representing the color information (hue and saturation) when the image is represented as separate chrominance and *luminance*. Same as “chroma”.
- Clean Aperture** ► The fraction of a motion picture *frame* image that is intended to be viewed by the audience. The clean aperture is subjectively free of edge artifacts and lies within the screen area framed by curtains in a cinema. Aspect ratio is often referenced to the clean aperture.

- Color Gamut** ► The range of colors allowed in a specific system, as defined within a triangular area located on the CIE color locus diagram whose corners are the three primaries defined in the system. Also known as color space.
- Color Shift** ► A change in the tint of a white field across an image.
- Color Temperature** ► The coloration (reddish, white, bluish, greenish, etc.) of white in an image, measured using the Kelvin (degrees K) temperature scale. Higher temperatures output more light.
- Component Video** ► See *YCbCr* or *YPbPr*.
- Composite Video** ► The output of video tape players and some computers, characterized by synchronization, luminance and color signals combined on one output cable.
- Contrast (ratio)** ► The degree of difference between the lightest and darkest areas of the image.
- Convergence** ► The alignment of the red, green, and blue light elements of a projected image so that they appear as a single element. In this projector, convergence can be adjusted by Christie service personnel only.
- Curved Screen** ► A projection screen which is slightly concave for improved screen gain. Curved screens usually have screen gains which are greater than 1 but viewing angles much less than 180°. Curved screens are not recommended for use with this projector.
- DCDM** ► Digital Cinema Distribution Master. A file or collection of files formatted for exhibition and comprised of all the components of the *title*. A reference size of about 200 GB per title is likely.
- DDC** ► The Display Data Channel VESA standard enables communication between PCs and monitors, and is based on E-EDID protocol.
- DMD™** ► Digital Micromirror Devices™ used in this projector for processed red, green, and blue color data.
- DSM** ► Digital Source Master. A title's native source files in acquisition format, edited to create the distribution master and for reformatting for NTSC, HDTV, DVD, etc., and potentially archived.
- DVI** ► The Digital Visual Interface standard signal supplies analog or digital RGB, sync, I²C, and clock information to the processing electronics in the projection head.
- Detail** ► The sharpness of a display from a video source.
- Diffused Screen** ► A type of rear-projection screen which spreads the light striking it. Screen gain is typically less than 1 but audience viewing angles are increased. Rarely used in cinema.
- Digital Cinema** ► Professional public presentation of theatrical content by electronic means, particularly emphasizing projectors whose image source is digital data. Also known as d-cinema and (rarely) e-cinema.
- Digital Interpolation** ► Also known as digital scaling. The process of averaging pixel information when scaling (resizing) an image up or down. When reducing the size of an image, adjacent pixels are averaged to create fewer pixels. When increasing the size of an image,

additional pixels are created by averaging together adjacent pixels in the original smaller image.

- Dot Clock** ► The maximum frequency of the pixel clock. Also known as pixel clock rate.
- E-EDID** ► The Enhanced Extended Display Identification Data standard, established by VESA, enables properties (such as resolution) of a display device to be detected by the display card in a controlling device such as a PC. The PC, in turn, can then output in a matching format to fill the display. Some sources used with the projector are VESA E-EDID reported.
- Foot-candle** ► The intensity of visible light per square foot.
- Footlambert** ► The luminance (brightness) which results from one foot-candle of illumination falling on a perfectly diffuse surface. $1 \text{ fL} = 3.423 \text{ candela per square meter (cd/m}^2\text{)}$. Note that SMPTE RP 98 calls for theatre screen luminance of **12 to 22 fL**; $16 \pm 2 \text{ fL}$ ($55 \pm 7 \text{ cd/m}^2$) is the open gate target according to SMPTE 196M. For cinema applications, *xenon lamp* wattage is approximated to achieve this level using $12 \text{ W/ft}^2 \times (\text{screen height squared})$ or 5 W/ft^2 of total 'scope image area, for matte screens and typical lenses.
- Frame Rate** ► The frequency at which complete images are generated. For non-interlaced signals, the frame rate is identical to the vertical frequency. For interlaced signals, the frame rate (also known as field rate) is one half of vertical frequency.
- Gain or Screen Gain** ► The ability of a screen to direct incident light to an audience. A flat matte white wall has a gain of approximately 1. Screens with gain less than 1 attenuate incident light; screens with gain more than 1 direct more incident light to the audience but have a narrow viewing angle. For example: An image reflecting off a 10 gain screen appears 10 times brighter than it would if reflected off a matte white wall. Curved screens usually have larger gain than flat screens.
- GPIO** ► General Purpose Input Output, used for remote control of a limited number of programmable functions by direct signal or dry-contact connection.
- GVG** ► Grass Valley Group (formerly part of Tektronix). More specifically, the .gvg file format used for compressed video, audio, and timecode stream transfer in the Profile video server products, proposed for standardization by SMPTE and as a primary component of *MXF*. Initially implemented on *Fibre Channel* using *FTP* with *TCP/IP* but extensible to *XTP* or other protocols. Previously called *GXF: General Exchange Format*.
- HDCP** ► High-bandwidth Digital Content Protection protocol of keys and encryption helps prevent DVI source material from being copied.
- HDTV** ► High-definition Television (1035, 1080 and 1125 lines interlace, and 720 and 1080 line progressive formats with a 16:9 (i.e. 1.77) aspect ratio.
- Horizontal Frequency** ► The frequency at which scan lines are generated, which varies amongst sources. Also called horizontal scan rate or line rate.
- Horizontal Offset** ► The difference between the center of the projected image and the center of the projector lens. For clarity, offset is often expressed as the maximum percentage of the

image that can be projected to one side of the lens center without degrading the image quality.

- Hot Spot** ► A circular area of a screen where the image appears brighter than elsewhere on the screen. A hot spot appears along the line of sight and "moves" with the line of sight. High gain screens and rear screens designed for slide or traditional movie projection usually have a hot spot.
- Input** ► A physical connection route for a source signal, described by a 2-digit number representing 1) its switcher/projector location and 2) its slot in the switcher/projector. In this projector, sources connected at a switcher must be selected at the switcher rather than the projector.
- Input Signal** ► Signal sent from a source device to the projector.
- Interface Module** ► A device, such as the *Dual SD/HD-SDI Module*, that accepts an input signal for display by the projector.
- Interlace** ► A method used by video tape players and some computers to double the vertical resolution without increasing the horizontal line rate. If the resulting frame/field rate is too low, the image may flicker depending on the image content.
- Keystone** ► A distortion of the image which occurs when the top and bottom borders of the image are unequal in length. Side borders both incline in or out, producing a "keyhole" shaped image. It is caused when the lens surface is not parallel to the screen.
- LampLOC™** ► A Christie software feature where internal samples of light in a projector guide the precise position of the lamp along 3 axes—vertical, horizontal and distance to lens—so that lamp performance and output is maximized. Not available in all models.
- Linearity** ► The reproduction of the horizontal and vertical size of characters and/or shapes over the entire screen.
- Line of Best Viewing** ► When light from a projector is incident on a screen, the light reflects from the screen such that the angle of reflection equals the angle of incidence. The Line of Best Viewing is along the line of reflection.
- LiteLOC™** ► A Christie software feature where samples of output light from a projector trigger automatic adjustments in the lamp ballast power in order to maintain a constant light output over time. Also known as brightness tracking. Not available in all models.
- Loophrough (Loopthru)** ► The method of feeding a series of high impedance inputs from a single video source with a coaxial transmission line in such a manner that the line is terminated with its characteristic impedance at the last input on the line.
- Lumen** ► The unit of measure for the amount of visible light emitted by a light source. Rarely used in cinema applications, but common in most other projection applications.
- Luminance** ► The signal representing the measurable intensity (comparable to brightness) of an electronic image when the image is represented as separate *chrominance* and *luminance*. Luminance also expresses the light intensity of a diffuse source as a function of its area; measured in lumens or candles per square foot (1 lumen per square foot = 1 *footlambert*). SMPTE RP 98 calls for a luminance of 12 to 22 footlamberts for theatre screens. See: *Footlambert*.

- Lux** ► The amount of visible light per square meter incident on a surface.
1 lux = 1 lumen/square meter = 0.093 foot-candles
- Metadata** ► Descriptive data about the format of the content—i.e., “data about data”. Upon receiving metadata, digital cinema projectors will “know” the correct aspect ratio of the image, and the sound processor will “know” the correct format of the audio, all without effort on the part of the person setting up the show on a particular projector.
- NTSC Video** ► A 525-line resolution video output format of some video tape and disc players. There are two types of NTSC (National Television Standards Committee) video: NTSC 3.58 and NTSC 4.43. NTSC 3.58 is used primarily in North America and Japan. NTSC 4.43 is less commonly used.
- Non-cinema** ► Alternative program material such as concerts, plays, sporting events, and potentially corporate training or conferencing, presented in theatres in addition to motion picture exhibition.
- Non-Sync** ► Audio played in a theatre, generally from a CD, when the cinematic presentation is not running, such as during intermissions and prior to the start of film presentation.
- Non-unicode** ► The non-unicode method of encoding produces a concise character set of 256 alphanumeric characters typically used in for ASCII messaging in most Western languages. Virtually all projector functions can be executed remotely via non-unicode (default) or unicode messaging—this is auto-detected. See also *unicode*.
- Optical Screen** ► A type of rear-projection screen which re-directs light through the screen to increase image brightness in front of the screen. Screen gain is usually greater than 1 but audience viewing angles are reduced. Rarely used in cinema applications.
- PAL Video** ► PAL (Phase Alternating Line) video is a 50 Hz standard with 768 x 576 resolution. It is found on some video tape and disc players used primarily in Europe, China and some South American and African countries.
- PCF** ► Projector Configuration File, or Presentation Control File. A small file created by the content owner or installer that controls the presentation of the elements and data subdivisions constituting a single version of a title. The human readable component may identify the name of the title, its owner, its length, event points, and other attributes. The PCF specifies color space, target color gamut, gamma (a.k.a. “degamma”), aspect ratio and image position settings. It does not include screen masking (cropping) information. A d-cinema presentation or feature uses a PCF.
- Pixel (picture element)** ► The smallest discernible element of data in a digital image.
- Pixel Phase** ► The phase of the pixel sampling clock relative to incoming data.
- Pixel Tracking** ► The frequency of the pixel sampling clock, indicated by the number of pixels per line.
- Play List** ► A small file or script typically created by the exhibitor or installer that specifies the sequence of presentation of programs, including features and trailers.
- Playout** ► The equipment in a digital cinema theatre which delivers previously recorded signals in real time to the *playback* system. The playout may also receive, store, and process these signals prior to delivering them.

- Post Production** ► The phase in film-making that occurs primarily after production ends; its processes include picture editing, sound effects editing and mixing, ADR, Foley, titles and opticals, dubbing and print mastering, CGI and visual effects, and scoring. Post production culminates in acceptance of the original negative *answer print*. Even though post production officially begins on the last day of principal photography, post production facilities such as editing are utilized from very early in the production phase in order to save time.
- Projector-to-Screen Distance** ► The distance between the projector's front feet centers and the screen. More commonly known as "Throw Distance".
- Pull Up (Pull Down)** ► Shifting the frequency, sample rate, or frame rate to as to achieve a target frequency or time relationship with another signal, most commonly by +/- .1%—the ratio of NTSC to B&W TV frame rates. See: 3:2 *pulldown*.
- Pull-down List** ► A selectable menu item that unfolds into a list of options or choices.
- QuVis** ► A manufacturer of a digital video recorder/player/server, QuBit, frequently used for providing digital cinema data. QuVis image compression uses a proprietary technology called Quality Priority Encoding, based on *wavelets*, in which the user selects a quality level based on *signal-to-noise ratio*. The data rate varies to efficiently maintain that quality level. Frames are coded individually.
- Rear Screen** ► A translucent panel for screen projection. Incident light travels through the incident surface of a rear screen and forms an image on the other surface. Rarely used for cinema applications.
- Release Print** ► Composite positive motion picture prints, generally made from *internegatives*, intended for distribution to exhibitors.
- Resizing** ► The ability to manipulate the physical size, placement and/or aspect ratio of an image. Also called scaling.
- Resolution** ► The maximum number of pixels that a display device can display horizontally and vertically across an image, such as 1400 x 1050 (SXGA+) or 2048 x 1080.
- Retrace Time (Horizontal)** ► The minimum time required for a CRT projector to move the position of the scanning spot from the right edge to the left edge.
- RGB Video** ► The video output (analog or digital) of most computers. Analog RGB video can have 3, 4, or 5 wires — one each for red, green, and blue, and either none, one or two for sync. For three-wire RGB, the green wire usually provides sync. (See TTL Video).
- RS232** ► A common asynchronous data transmission standard recommended by the Electronics Industries Association (EIA). A type of serial communication.
- RS422** ► A less common asynchronous data transmission standard in which balanced differential voltage is specified. RS422 serial communication is especially suited to long distances.
- S-Video** ► The output from certain video tape players and video equipment. S-Video separates sync and luminance from color information, typically producing a higher quality display than composite video. Also known as Y/C.
- Scan Frequency** ► The horizontal or vertical frequency at which images are generated. Also known as scan rate or refresh rate.

- Scan Line** ► One horizontal line on the display.
- SECAM** ► A video output format of some video tape and disc players used primarily in France. SECAM (Sequential Couleur à Mémoire) signals are similar in resolution and frequency to PAL signals. The primary difference between the two standards is in the way color information is encoded.
- Show Script** ► A small file consisting of *automation cues* in addition to a play list, triggering theatre events (action data), and possibly including parameters that allow the program to be tailored for a specific venue or engagement. A show script is created by the exhibitor or installer and provides automated presentations.
- Source** ► The device (such as a server) connected to the projector for supplying incoming data.
- Source Setup** ► See *Channel*.
- Switcher** ► A signal selector such as the *Marquee Signal Switcher* formerly manufactured by Christie that can be connected for adding more sources to a projector.
- Sync** ► The part of the video signal that stabilizes the picture. Sync can occur in three forms:
- 1) "Composite sync": the horizontal and vertical components are together on one cable.
 - 2) "Sync-on-green": the sync is part of the green video.
 - 3) "Separate sync" or "H.SYNC and V.SYNC": the horizontal and vertical components of the sync are on two separate cables.
- Sync Width** ► The duration of each sync pulse generated by a computer. The sync width is part of the blanking time.
- TTL Video** ► A type of RGB video with digital characteristics.
- Terminated** ► A wire connecting a single video source to a display device, such as a projector, must be terminated by a resistance (usually 75Ω for video).
- Throw Distance** ► The distance between the front bezel of the projector and the screen. Also called "Projector-to-Screen Distance". Always use the correct Christie throw distance formula to calculate the proper throw distance ($\pm 5\%$) required for your lens.
- Throw Ratio** ► Throw ratio = throw distance / screen width. Typically used to differentiate lenses.
- Tint** ► Balance of red-to-green necessary for realistic representation of NTSC signals.
- TMDS** ► Transition Minimized Differential Signaling is the basis for DVI (Digital Visual Interface).
- Unicode** ► The Unicode method of encoding produces a very large character set typically required for ASCII messaging in non-Western languages such as Chinese, Russian, etc. In unicode, every number (code) is unique to a single character. Menu functions can be executed remotely via unicode or non-unicode (default) messaging—this is auto-detected. See also *non-unicode*.
- Variable Scan** ► The ability of a projector to synchronize to inputs with frequencies within a specified range.

- Vertical Frequency** ► The frequency at which images are generated or “output”. Vertical frequencies vary amongst sources. Also known as vertical scan rate.
- Vertical Offset** ► The difference between the center of the projected image and the center of the projector lens. For clarity, offset is often expressed as the maximum percentage of the image that can be projected above or below the lens center without degrading the image quality.
- VESA** ► The Video Electronic Standards Association establishes standards of communication between electronic components to help ensure universal compatibility.
- Video** ► The signal that is used by display devices (such as projectors) to generate an image. This term also refers to the output of video tape/disk players and computers.
- Video Decoder** ► A module that converts NTSC 3.58, NTSC 4.4, PAL, PAL-N, PAL-M or SECAM to RGB video. An 8-bit video decoder is standard in this projector.
- Video Standard** ► A specific type of video signal, such as NTSC, PAL, SECAM.
- Viewing Angle** ► Screens do not reflect equally in all directions. Instead, most light is reflected in a conical volume centered around the "line of best viewing". Maximum brightness is perceived if you are within the viewing cone defined by the horizontal and vertical viewing angles.
- Watermark** ► Data embedded in essence that serve different purposes and that are either imperceptible or obvious, robust or fragile. Their usual purpose is for legal support of copyright, and they may also be components of copy control schemes.
- White Balance** ► The color temperature of white used by the projector.
- White Field** ► The area of an image that is white only. For example, a full white field is an image that is white everywhere. A 10% white field is a white area (usually rectangular) that occupies 10% of the image; the remaining 90% is black.
- YCbCr** ► A high-end *digital* component video signal.
- YPbPr** ► A high-end *analog* component video signal. Sometimes called YUV, Component, or Y, R-Y, B-Y, the YPbPr signal by-passes video decoding.
- YUV** ► See *YPbPr*.
- Zoom** ► The adjustment of image size by means of a zoom lens.

Remote Keypad

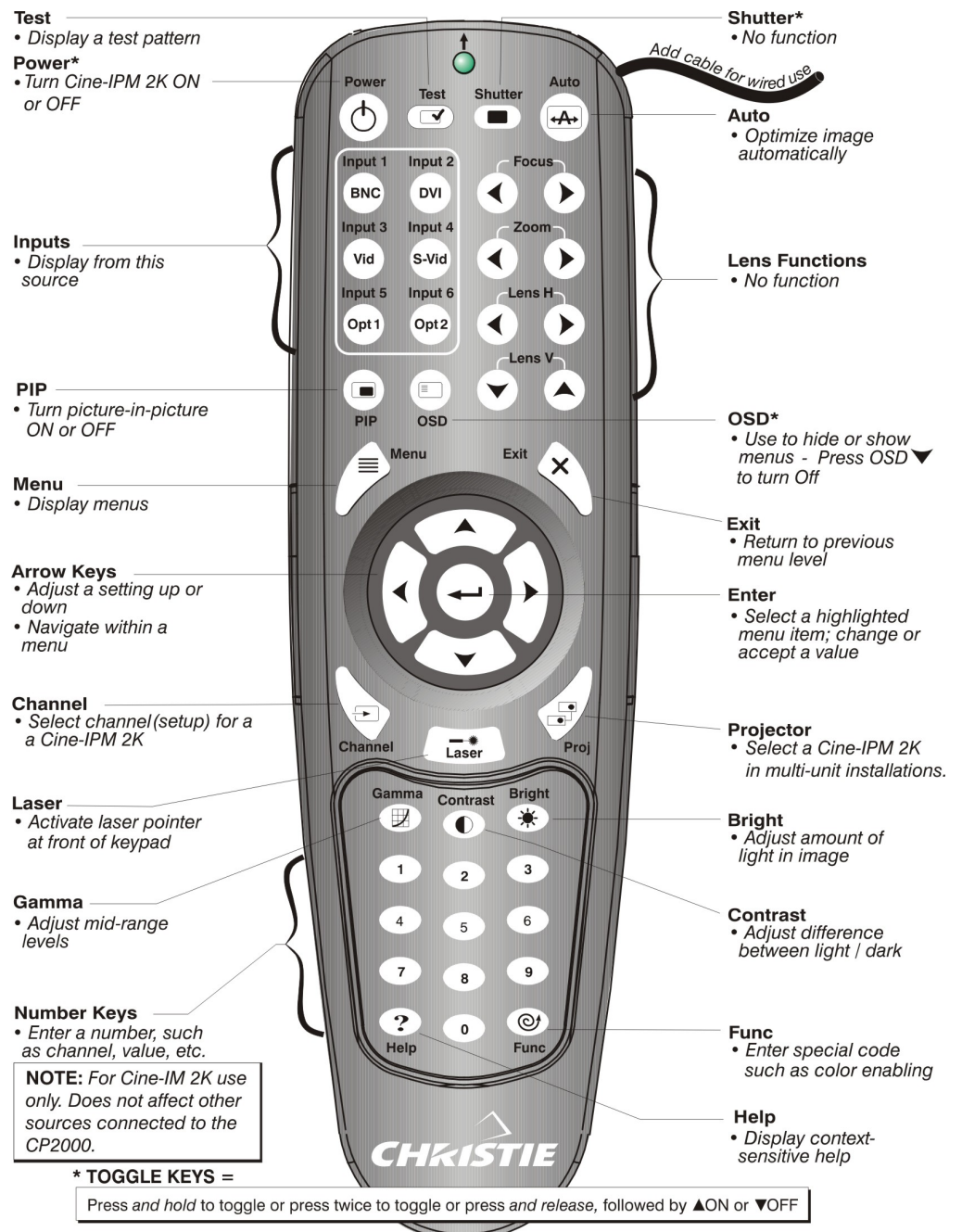

Figure B.1. Standard Remote Keypad

Serial Communication Cables

Serial Links to Projector ► **FOR GENERAL COMMUNICATIONS:** A serial link of RS232 or RS422 enables ASCII communication with the *Cine-IPM 2K* so that it can be controlled remotely from a PC or other controller. From a PC, connect a standard 9-wire RS232 serial cable to the **RS232 IN** port located on the *Cine-IPM 2K* front panel. Or, for long-distance (>100 ft.) links with an RS422-compatible PC or controller, connect RS422 cable to the **RS422** port.

FOR SOFTWARE DOWNLOADS: Download new software to the *Cine-IPM 2K* via either serial link.

NOTE: Using an Ethernet link for downloading new software to the projector is not supported.

□ **From Cine-IPM to computer (RS232)**

For computers having a 9-pin "AT" type serial port

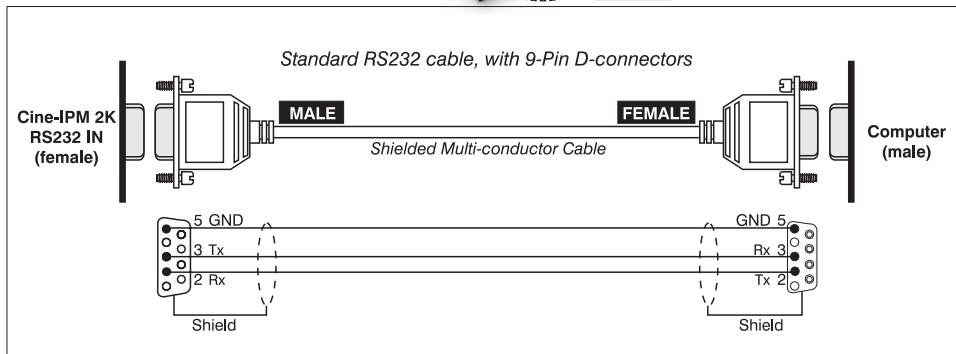

□ From Cine-IPM 2K to RS422 compatible computer

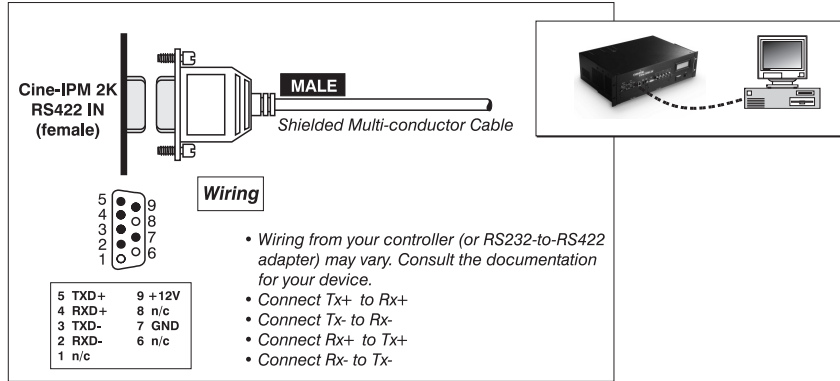

□ From Cine-IPM 2K to Cine-IPM 2K

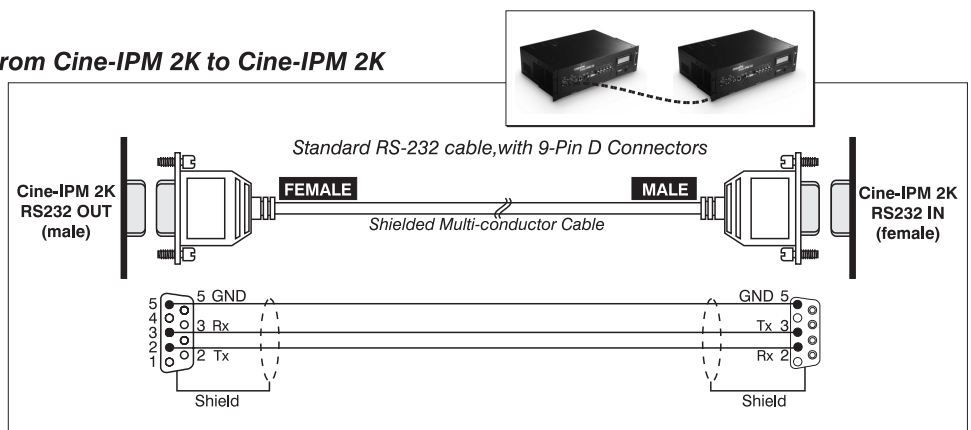

System Integration

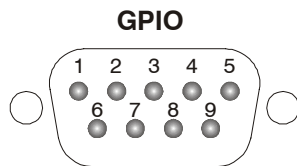

The GPIO connector located on the *Cine-IPM 2K* front panel provides a flexible method of interfacing a wide range of external I/O devices to the *Cine-IPM 2K*, usually so that an event on one device automatically triggers an event on the other. There are 7 GIO pins available on the 9pin D-Sub GPIO connector, all of which are configurable via RS232 commands. The remaining two pins are reserved for ground and power – see table below for pin identification.

GPIO Pins	
Pin #	Signal
1	+12V (200mA)
2	GPIO 1
3	GPIO 2
4	GPIO 3
5	Ground
6	GPIO 4
7	GPIO 5
8	GPIO 6
9	GPIO 7

The serial cable required for connecting the external device to the *Cine-IPM 2K*'s GPIO connector, whether it's a standard or custom cable, must be compatible with the external device.

Configuring the GPIO ► The GPIO connector can be configured to automate any number of events using the serial command code **GIO**. Each pin is defined as either an *input* or *output* depending on the desired outcome. In general, configure the pin as an input if you want the projector to respond to something an external device does, and as an output if you want the external device to respond to an action taken by the projector. For example, configure the pin as an output if you want the lighting in a room to automatically dim when the projector is turned on.

A **GIO** command can also set the state of each pin as *high* or *low*. By default, the state of each pin is *high*. The voltage applied to pins in the *high* state is + 3.3V.

Example 1. Turn room lighting on when the projector is turned off. (Assumes a control/automation unit is configured to turn the lights on when pin 2 of its input goes high.)

(GIO C2 O)

Set pin #2 configuration to output

(GIO 2 H)

Set pin #2 to high (state)

- Query Command** ▶ (GIO?) Request the state and configuration of all pins
 (GIO! "HLLLHLH" "OOIOOOI") Reply of pin state and configuration
 (GIO? C2) Request configuration for pin #2
 (GIO! C2 O) Reply with pin #2 configuration as output
 (GIO? 2) Request the state of pin #2
 (GIO! H) Reply with pin #2 state as high

Real Time Event ▶ Use the serial command **RTE** to specify an action that is initiated at a particular time or based on an external stimulus.

For General Purpose IO "G"

Parameter	Name	Value
P1	RTE type	G (Real Time I/O Event)
P2	I/O bit	1-7
P3	Pin state (1 Character) (String)	H = High L = Low "LHXXXHLX" Combine multiple inputs and trigger occurs when all conditions are met
P4	Commands	Any valid serial protocol command for the device

Example 2. Projector powers up when a switch on the external device is turned on.

- (GIO C2 I) Set pin #2 configuration as input
 (RTE G 2 H "(PWR 1)") Power on when pin #2 set to high
 (RTE G 2 L "(PWR 0)") Power off when pin #2 set to low

Optional Input Modules

The following optional input modules can be installed in either option slot in the *Cine-IPM 2K* (**INPUT 5** or **INPUT 6**). Contact your dealer for a complete and up-to-date listing.

NOTE: Any audio connectors shown are non-functional in the Cine-IPM 2K.

- RGB500 Input Module** 38-804606-xx ► This module receives analog RGB input signals from computers or other RGB source devices.

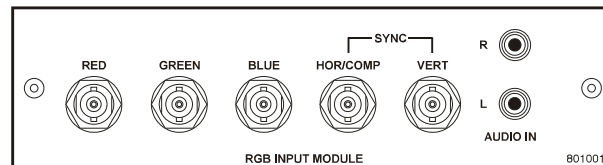

RGB500 Features

- ◇ accepts 3, 4, or 5 wire RGB video (sync-on-green, composite sync, or separate horizontal and vertical sync), up to 500 MHz bandwidth
- ◇ BNC connectors for RGB signal inputs

- RGB400BA Input Module** 38-804610-xx ► Connect three-, four-, or five-wire RGB video signals of up to 400 MHz bandwidth—these are signals typically produced by high-resolution computer or workstations. The buffering capability of the module enables the incoming signal to be sent to a remote destination. Inputs are 75 Ω terminated.

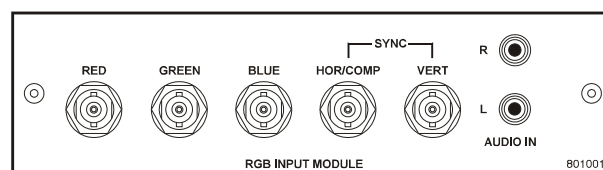

RGB400BA Features

- ◇ accepts 3, 4, or 5 wire RGB video (sync-on-green, composite sync, or separate horizontal and vertical sync)
- ◇ BNC connectors for RGB signal inputs
- ◇ Buffered signals to a remote destination

- RGB400 Active Loop-Thru Input Module** 38-804607-xx ► This module receives analog RGB input signals from computers or other RGB source devices. Video inputs are 75 Ω terminated. Video outputs provide buffered loop-through to another display device.

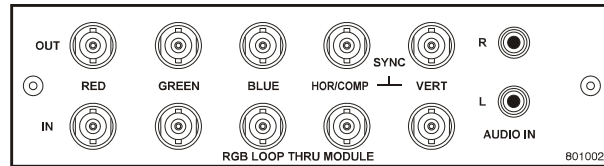

RGB400ALT Features

- ◇ accepts 3, 4, or 5 wire RGB video (sync-on-green, composite sync, or separate horizontal and vertical sync)
- ◇ BNC connectors for RGB signal inputs
- ◇ buffered loop-through video outputs

PC250 Analog Input Module 38-804609-xx

► This module receives analog RGB input signals from IBM PC compatibles or Macintosh computers. Video inputs are 75Ω terminated. Outputs are provided for buffered loop-through to another display device.

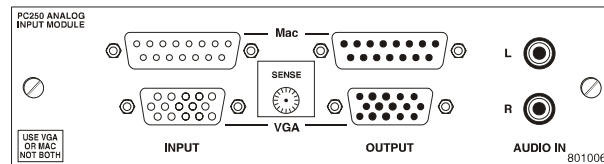

PC250 Analog Features

- ◇ accepts VGA or MAC RGB video
- ◇ 15 pin D connectors for video
- ◇ active loop-through video outputs

NOTE: This interface does not accept VGA and MAC signals simultaneously.

DVI Input Module 38-804635-xx

► This module can display digital video input signals conforming to the DVI (Digital Visual Interface) single-channel standard.

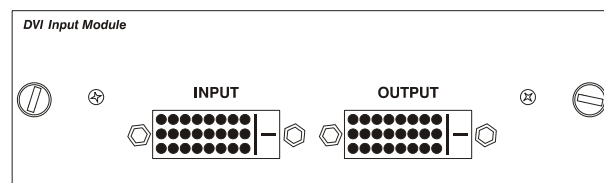

Features

- ◇ Supports Digital Visual Interface (DVI) single-channel
- ◇ Supports VESA® Extended Display Identification Data (EDID™)
- ◇ Provides an active-loop-through using a DVI connector (conforming to the DVI Specification)

Serial Digital Input Module 38-804602-xx

► This module accepts a serial digital 4:2:2 component video signal (YCbCr) via a single **SERIAL IN** BNC connector. The signal can loop through the **SERIAL OUT** BNC out to another device (such as another *Cine-IPM 2K / CP2000*). Inputs are 75Ω terminated.

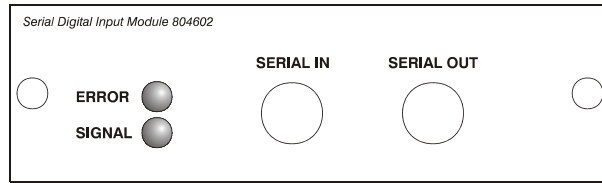

SDI Features

- ◇ accepts serial digital 4:2:2 component video (YCbCr)
- ◇ provides both a **SERIAL IN** and a **SERIAL OUT** BNC connector
- ◇ includes status LEDs for signal and error

Dual SD/HD-SDI Module 38-804656-xx

► This module accepts one or two independent standard- or high-definition serial digital inputs, decodes them for processing in the main electronics of the *Cine-IPM 2K*, and outputs 10-bit YCbCr 4:2:2 video. Either input can be set as the active primary or secondary part of a Picture-in-Picture display, and either input can be looped through to one (or both) of the module’s BNC outputs.

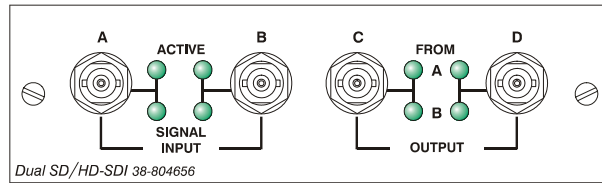

Dual SD/HD-SDI Features

- ◇ accepts and decodes up to two serial digital inputs
- ◇ outputs up to two 10-bit RGB/YCbCr 4:2:2 video signals
- ◇ provides input(s) to output(s) loop-through capability
- ◇ supplies interchangeable inputs for Picture-in-Picture displays
- ◇ SMPTE 259M compatible

Optional Input Modules

1

- 10-bit Output
 - How to Connect For, 2-9
 - How to Use, 2-9
 - Selecting at the TPC, 2-10

8

- 8-bit Output
 - How to Connect For, 2-3, 2-4
 - How to Use, 2-9
 - Selecting at the TPC, 2-10

A

- AC
 - Safety, 4-1
 - Troubleshooting, 5-1
- Active Input Window, 3-22
- Advanced Image Settings Menu, 3-30
- Advanced Size and Position Menu, 3-22
- AGC, 3-25
- All Joined (Network Setting), 3-36
- Anamorphic Image, 3-21
- Arrow Keys, 3-9
- ArtNet Device Description, 3-38
- ArtNet Device Name, 3-38
- ASCII Messaging, 3-49
- Auto Color Enable, 3-28
- Auto Input Level, 3-27
- Auto Power-up, 3-33
- Auto Setup, 3-5, 3-18
- Automatic Gain Control. *See* AGC
- AutoSource Checkbox, 3-18

B

- Bad Sync, 3-61
- Baud Rate, 2-16
- Baud Rate Settings, 3-35
- Blacklevels and Drives, 3-28
- Blanking, 3-22
- Brightness Key, 3-7, 3-24

- Brightness Uniformity
 - Canceling, 3-56
 - Definition, 3-53
 - Prerequisites, 3-53
 - Procedure, 3-53
 - Submenu, 3-39
- Broadcasting, 3-8, 3-38

C

- Channel
 - Input, 3-18
 - Locked, 3-18
 - Name, 3-17
 - Number, 3-14, 3-18
 - Signal Type, 3-15
- Channel Copy/Delete, 3-16
- Channel Edit Menu, 3-17
- Channel Key, 3-5, 3-14
- Channel Selection, 3-15
- Channel Setup Menu, 3-15
 - And Enter Key, 3-16
 - And Function Key, 3-16
- Channels
 - Creating Automatically, 3-14
 - Creating in Channel Setup Menu, 3-16
 - Definition of, 3-14
 - Deleting in Channel Setup Menu, 3-16, 3-17
- Channels vs. Inputs, 3-13
- Checkbox Toggles, 3-11
- Cine-IPM 2K*
 - and TPC Settings, 2-14
 - Netwo Communication with CP2000, 2-4
 - Components, 3-1, 6-4
 - Features, 1-1
 - Installation in *CP2000*, 2-1
 - Resetting, 3-62
 - Specifications, 6-1
 - Standard Components, 1-2
 - Status Display, 3-60
 - Turning on/off, 3-5
- Clamp Location, 3-28
- Color (Video Option), 3-26

- Color Adjustment
 - Color Saturation Submenu, 3-42
 - XY Submenu, 3-41
- Color Enable, 3-28, 3-43
- Color Matching, 3-50
- Color Space, 3-25
- Color Temperature, 3-31
- Communications Menu, 3-35
- Component Video, 2-6
- Configuration Menu, 3-32
- Contrast Key, 3-6, 3-23
- Controllers, 3-49
- Cooling
 - Maintaining Proper, 4-2
- CP2000, 2-1
- Custom Sizing, 3-19

D

- DDOM, 3-62
- Decoder Luma Delay, 3-27
- Detail (Menu Option), 3-24
- Detail Threshold, 3-32
- DHCP Server, 2-13, 2-17, 3-36
- Display Channel List, 3-34
- Display Error Messages, 3-34
- Display Slidebars, 3-34
- Dual SD/HD-SDI
 - Using Input On, 3-6
- DVI Outputs
 - Connection of, 2-9

E

- EEPROM, 3-62
- Edge Blending, 3-40
 - Description, 3-57
 - How Blends are Used, 3-57
 - Main functions, 3-58
- Enable Decoder AGC, 3-25
- Enter Key, 3-8
- Error Messages
 - Bad Sync, 3-61
 - How to Find, 3-60
 - H-Sync or V-Sync, 3-61
 - No Signal, 3-61
 - System Warnings/Errors, 3-61
- Ethernet
 - Factory-set, 1-2
 - How to Connect, 2-12
 - IP Address Change, 2-17
 - Networks, 2-17
 - Troubleshooting, 5-1
- Ethernet Settings Menu, 3-36*
- Exhaust
 - Airflow Maintenance, 4-2
- Exit Key, 3-8

F

- Film Mode Threshold, 3-32
- Filter (Menu Option), 3-24
- Floating Inputs, 3-32
- Frame Delay Monitor, 3-31
- Frame Lock, 3-31
- Freeze Image, 3-42
- Full Height, 3-20
- Full Screen, 3-20
- Full Width, 3-20
- Function Key Codes, 3-7

G

- Gamma, 3-7, 3-24, 6-1
- Gamma Table, 3-30
- General Purpose In/Out. *See* GPIO
- GPIO, 2-13

H

- HDTV Connection, 2-8
- Help
 - Context-sensitive, 3-10
 - General Topics, 3-10
- Help Key, 3-5
- Horizontal Position, 3-22
- Horizontal Shift, 3-34
- Hum bars 3-32

I

- Image Adjustments, 3-18
- Image Settings Menu, 3-23
- InMenu Checkbox, 3-18
- Input 1, 2-6
- Input 2, 2-8
- Input 3, 2-7
- Input 4, 2-7
- Input 7, 3-6
- Input 8, 3-6
- Input Levels Menu, 3-27*
- Input Video Black, 3-26
- Inputs
 - Connection, 2-2
 - Definition of, 3-13
 - Input Keys, 3-6
 - Selecting/switching, 3-13
 - Specifications, 6-1
 - Types, 1-1
- Installation
 - Ethernet, 2-12
 - Serial Communications, 2-11
- Installation Tips, 2-4
- Interfaces, Optional, 2-8
- Invalid Channel, 3-61
- IP Address, 1-2, 2-17, 3-36
 - Network Name, 3-32

K

Keypads, IR or Wired. *See* Remote Keypads

L

Language Setting, 3-33
 LEDs, Status Codes, 3-62
 Lens Keys, 3-9
 Level Detector, 3-44
 Level Value, 3-44
 Locked Channel Checkbox, 3-18
 Luma Delay, 3-27

M

Main Menu, 3-9
 Menu
 Advanced IMage Settings, 3-30
 Advanced Size and Position, 3-22
 Channel Edit, 3-17
 Channel Setup, 3-15
 Communications, 3-35
 Configuration, 3-32
 Ethernet Settings, 3-36
 Image Settings, 3-23
 Menu Preferences, 3-34
 Odd Pixel Adjustment, 3-43
 PIP and Switching, 3-45
 Size and Position, 3-19
 Status, 3-48
 Video Options, 3-25
 Menu Font Size, 3-34
 Menu Key, 3-7
 Menu Location on Screen, 3-34
 Menu Navigation, 3-18
 Menu Preferences Menu, 3-34
 Menu Time-outs, 3-10
 Menus
 Blind Use Of, 3-11
 Motion Filter, 3-32

N

Native Format Displays, 3-20
 Network Name, 2-18
 Network Routing, 3-35
 Networks
 Ethernet, 2-17
 Separate, 3-35
 Setup in Software, 3-35
 No Resizing, 3-20
 No Signal, 3-61
 Noise Reduction, 3-25
 Numbers Select Main Image, 3-48
 Numerical Entry, 3-13

O

Odd Pixel Adjustment Menu, 3-43
 Option 1, 3-6
 Optional Input Modules, 3-45
 Optional Inputs, 2-8
 OSD Key, 3-7
 Output Format, 3-33
 Output Format Submenu, 2-10

P

Peak Detector, 3-29, 3-44
 Picture-in-Picture. *See* PIP Key
 PIP
 Border Color, 3-47
 Border Width, 3-47
 Enable, 3-46
 PIP and Switching Menu, 3-45
 PIP Image Settings, 3-47
PIP Key, 3-9
 PIP Size and Position, 3-47
 Pixel Phase, 3-21
 Pixel Tracking, 3-21
 Plug & Display (EDID), 3-23
 Port (Ethernet Setting), 3-37
 Power
 Troubleshooting, 5-1
 Primary Colors, Adjusting, 3-50
 Projector Key, 3-8
 Projector Number, 2-19, 3-35
 Pull-Down Lists, Use of, 3-11

R

Remote Keypads, 3-3
 Guide to Keys, 3-4
 IR, 3-3
 Keys and Use, 3-3
 Remapping for Inputs, 3-48
 Wired, 3-3
 Resize Presets, 3-19
 RS232
 Connection, 2-11
 Networks, 2-15
 Specifications, 6-3
 RS232 and Ethernet Joined, 3-36
 RS232 and RS422 Joined, 3-36
 RS422
 Connection, 2-11
 Networks, 2-16
 Specifications, 6-3

S

Select Color Adjustment, 3-30
 Serial Communication, 2-11
 Service Contacts, 1-2
 Set Date & Time, 3-33
 Shutter Key, 3-7

- Size and Position Menu, 3-19
- Size of Image, 3-19, 3-21
- Slider Adjustment, 3-10
- Splash Screen Setup, 3-34
- Split Networks
 - Options for Setup, 2-18
- Status Menu, 3-48
- Swap Main and PIP Image. *See* PIP
- Sync
 - Def. and types, A-8
- Sync Tip Clamping. *See* Clamp Location

T

- Test Pattern Grey Level, 3-42
- Test Pattern Key, 3-5
- Test Patterns via Menus, 3-39, 3-42
- Text
 - Editing, 3-12
- Tint (Video Option), 3-26
- TPC Settings, 2-14, 2-15, 3-33
- Troubleshooting
 - Displays, 5-1
 - Ethernet, 5-1
 - Power, 5-1

- Twin Link. *See* 10-bit Output

U

- UV Warnings, 4-1

V

- Vertical Position, 3-22
- Vertical Shift, 3-34
- Vertical Stretch, 3-21
- Video Options Submenu, 3-25
- Video Standard, 3-26

W

- Warnings for Operation, 4-1
- Whitelevels Adjust, 3-27
- Wired Remote. *See* Remote Keypads

Y

- YPbPr, 3-25
 - Connection, 2-6